

(2) DETAIL B

PART NUMBER TABLE	
PART NUMBER	DESCRIPTION
5061001	POSITION-IT 150 FT-LB 24VDC BLK - SOFTWARE V1.3W
5061002	POSITION-IT 150 FT-LB 24VDC BLK - SOFTWARE V1.3W MAD

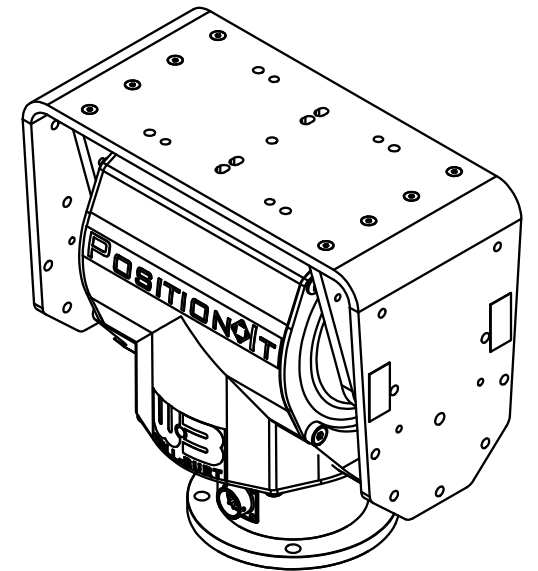

FACTORY PRESET HOME POSITION (PRESET 0)

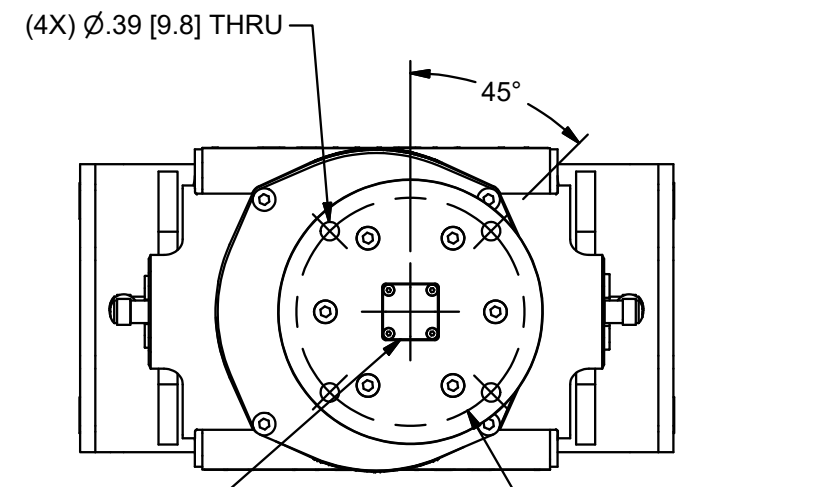
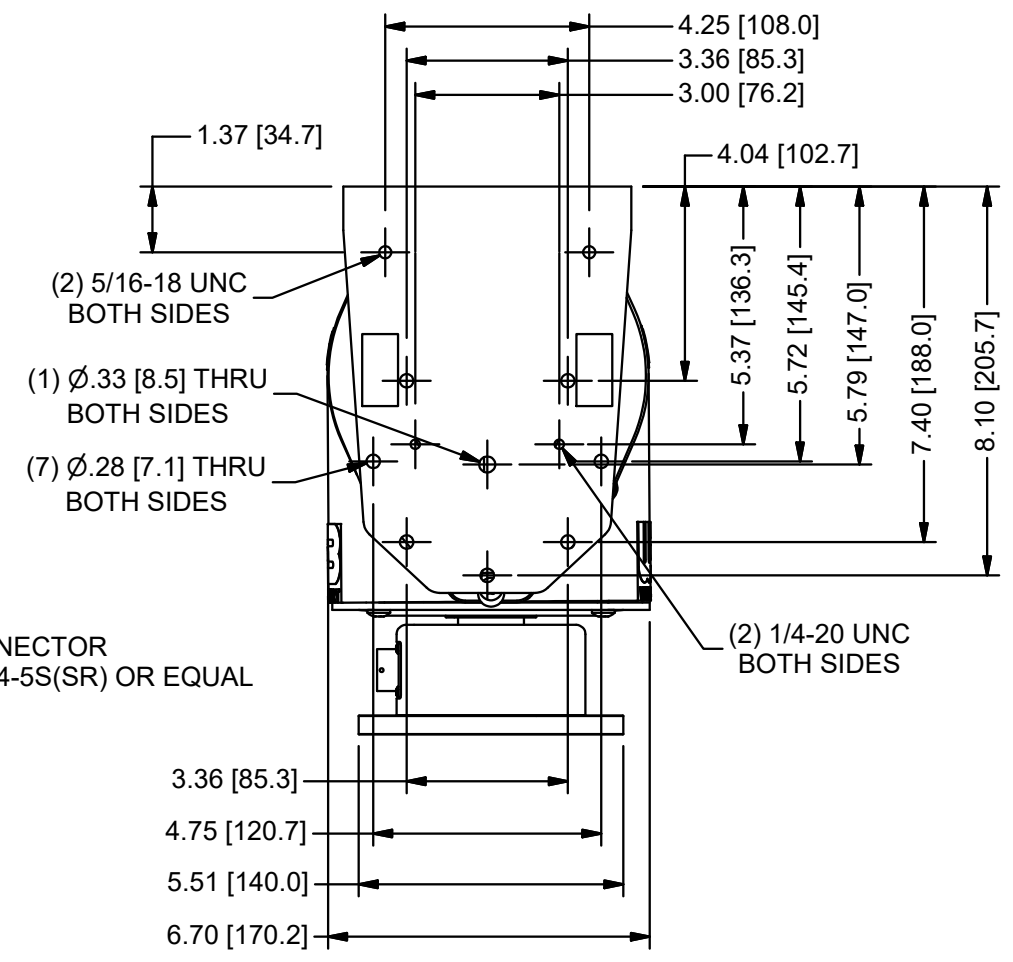
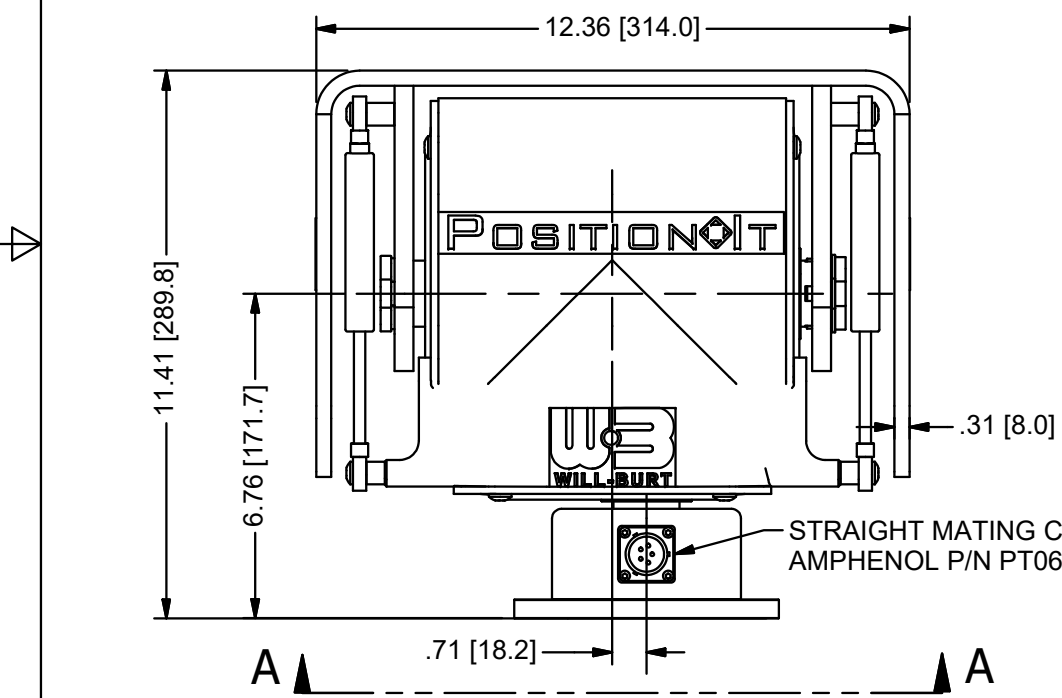

VIEW A-A

NOTES:  
 PAN GEAR BOX SPEED (MAX) - 6.5° PER SECOND  
 TILT GEAR BOX SPEED (MAX) - 5.5° PER SECOND  
 PAN/TILT OUTPUT TORQUE - 202 Nm (150 ft-lbs)  
 PAN DEGREES OF ROTATION - ± 200°  
 TILT DEGREES OF ROTATION - ± 90°  
 BACKLASH - <0.15°  
 REPEATABILITY <0.3°  
 IP68 RATED FOR DUST AND WATER INTRUSION  
 TEMPERATURE RANGE - (-20)° TO +50° C  
 24 VDC POWER INPUT  
 ALTERNATE UNITS ARE MILLIMETERS  
 CABLE AND CONTROLLER SOLD SEPARATELY  
 SEE OPERATING MANUAL FOR INSTALLATION WIRING DIAGRAM  
 ALL DIMENSIONS ON SHEET 1 ARE FOR REFERENCE ONLY

MATERIAL	UNLESS OTHERWISE SPECIFIED DIMENSIONS ARE IN INCHES. TOLERANCES ON DECIMALS ANGLES 0 ± 0.030 ± 1/2° 00 ± 0.010 000 ± 0.005 FRACTIONAL ± 1/64"	THE INFORMATION CONTAINED IN THIS DRAWING IS THE SOLE PROPERTY OF THE WILL-BURT COMPANY ANY REPRODUCTION IN PART OR WHOLE WITHOUT THE WRITTEN PERMISSION OF THE WILL-BURT COMPANY IS PROHIBITED.	AN EMPLOYEE OWNED COMPANY ORRVILLE, OH			
FINISH	BLACK RAL9005		TITLE	POSITION-IT 150 FT-LB POSITIONER 24V BLK		
APPROX. WT: 37 lbs	1. ALL INSIDE EDGES TO HAVE .005" TO .035" FILLETS. 2. ALL OUTSIDE EDGES TO HAVE .005" TO .015" CHAMFER OR RADIUS.	APPROVALS	DATE	SIZE	DWG NO	REV
THIRD ANGLE PROJECTION	125 ON ALL MACHINED SURFACES	jeamer	6/10/2014	B	50610	D
		CHECKED		PN:	SEE TABLE	SHEET 1 OF 2