

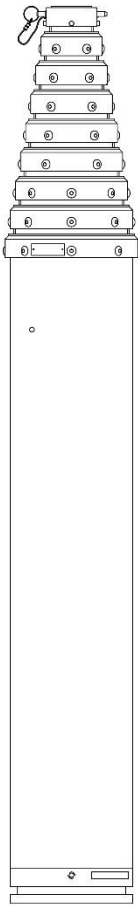

PNEUMATIC MAST OPERATOR'S MANUAL

(STANDARD, HEAVY-DUTY, AND SUPER-HEAVY-DUTY MODELS)



Non-Locking
(P/N: 906035 Shown)

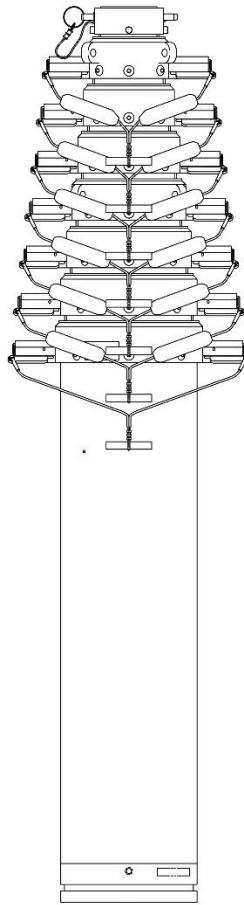

Locking Mast with T-Handle Yoke Assembly
(P/N: 906051 Shown)

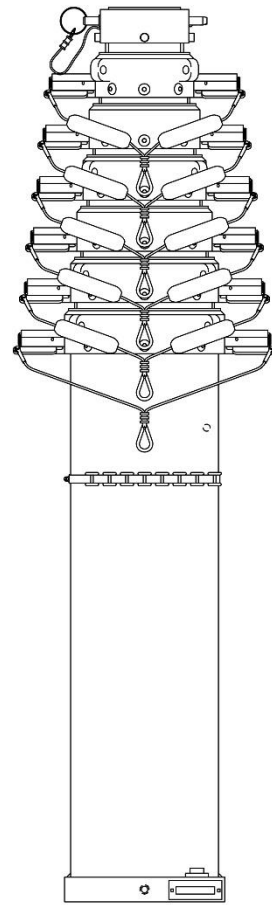

Locking Mast with Trip Lines
(P/N: 906053 Shown)

The Will-Burt Company
169 S. Main Street
Orrville, OH 44667

www.willburt.com
TP-4022306-E, August 2018
© 2018 The Will-Burt Company
Original Instructions

Pneumatic Mast Warranty

Will-Burt warrants its pneumatic masts to be free from defects in material and workmanship for a period of five (5) years when used in commercial applications and two (2) years when used in military applications, with such time periods running from the date of shipment by Will-Burt. Will-Burt shall not be responsible for any damage resulting to or caused by its products by reason of failure to properly install, maintain or store the product; use of the product in a manner inconsistent with its design; unauthorized service, alteration of products, neglect, abuse, accident, or acts of God. This warranty does not extend to any component parts not manufactured by Will-Burt; provided, however, Will-Burt's warranty herein shall not limit any warranties by manufacturers of component parts which extend to the buyer.

THE FOREGOING WARRANTY IS IN LIEU OF ALL OTHER WARRANTIES, AND NO REPRESENTATIONS, GUARANTEES OR WARRANTIES, EXPRESS OR IMPLIED, INCLUDING BUT NOT LIMITED TO, A WARRANTY OF MERCHANTABILITY, FITNESS FOR A PARTICULAR PURPOSE, OR NON-INFRINGEMENT ARE MADE BY WILL-BURT IN CONNECTION WITH THE MANUFACTURE OR SALE OF ITS PRODUCTS. NO EMPLOYEE, DISTRIBUTOR, OR REPRESENTATIVE IS AUTHORIZED TO CHANGE THIS WARRANTY IN ANY WAY OR GRANT ANY OTHER WARRANTY ON BEHALF OF WILL-BURT.

Claims for defects in material and workmanship shall be made in writing to Will-Burt within thirty (30) days of the discovery of defect. Failure to provide notice as required hereby shall be conclusive evidence that the product was in conformity with the warranty, and Will-Burt shall be released from any and all liability relating to the product. Will-Burt may either send a service representative or have the product returned to its factory at Buyer's expense for inspection. If judged by Will-Burt to be defective in material or workmanship, the product will be replaced or repaired at the option of Will-Burt, free from all charges except authorized transportation.

THE REMEDIES OF BUYER SET FORTH HEREIN ARE EXCLUSIVE AND ARE IN LIEU OF ALL OTHER REMEDIES. THE LIABILITY OF WILL-BURT WHETHER IN CONTRACT, TORT, UNDER ANY WARRANTY, OR OTHERWISE, SHALL NOT EXTEND BEYOND ITS OBLIGATION TO REPAIR OR REPLACE, AT ITS OPTION, ANY PRODUCT OR PART FOUND BY WILL-BURT TO BE DEFECTIVE IN MATERIAL OR WORKMANSHIP. WILL-BURT SHALL NOT BE LIABLE FOR COST OF INSTALLATION AND/OR REMOVAL, OR BE RESPONSIBLE FOR DIRECT, INDIRECT, SPECIAL OR CONSEQUENTIAL DAMAGES OF ANY NATURE.

EC Declaration of Conformity

In accordance with EN ISO 17050-1: 2010-08

The Will-Burt Company,
401 Collins Blvd.
Orrville Ohio, 44667 USA

Declare that:

Equipment: Pneumatic Mast System
Model Name: Standard-Duty Non-Locking
Heavy-Duty Non-Locking
Heavy-Duty Locking
Super-Heavy-Duty Non-Locking
Super-Heavy-Duty Locking
Model Number: All

In accordance with the following Directives:

2006/42/EG Directive
2004/108/EG Directive

Is in conformity with the applicable requirements of the following documents:

Ref. No.	Title	Edition/Date
BS EN ISO 12100-1&2	Safety of machinery, basic concepts, general principles for design.	2011-03
BS EN 60204-1	Safety of machinery. Electrical equipment of machines. General Requirements.	2011-06

Information may be requested from the following organization:

The Will-Burt Co. (EU) Ltd.
Unit 5b, Station Approach
Four Marks, Alton
Hampshire, GU34 5HN
United Kingdom

Document History

Document Numbers	Dates	Remarks
Pneumatic Mast Op. Man. Rev. 13	October 2012	Revised Tables, Reference Data 1.4
Pneumatic Mast Op. Man. Rev. 14	November 2013	Updated warranty page.
Pneumatic Mast Op. Man. Rev. 15	March 2014	Updated lubrication requirements.
Pneumatic Mast Op. Man. Rev. 16	April 2014	Adjusted by 0.05" the distance between the mounting holes for a 6 ¾" rotating base plate.
Pneumatic Mast Op. Man. Rev. 17	March 29, 2016	Updated Section 1.2 and 3.3.2. Added Section 4.5. Updated Tables 1-2, 1-4, 1-6, 1-8, and 1-10.
TP-4022306-A	March 30, 2017	Restructured and updated entire manual. Previously the manual was 4022306. Now the manual is TP-4022306.
TP-4022306-B	April 3, 2017	Updated Section 5.5.2
TP-4022306-C	September 7, 2017	Updated figures 1-3 and 2-24.
TP-4022306-D	February 12, 2018	Updated Section 2.3 and Section 5.5.2.
TP-4022306-E	August 2, 2018	Updated Section 1.5.6

Table of Contents

Section 1 Introduction	1-1
1.1 Safety Precaution Notification	1-1
1.2 Manual Organization	1-2
1.3 Definitions of Terms	1-2
1.4 Specifications	1-3
1.4.1 Standard-Duty Non-Locking Masts	1-4
1.4.2 Heavy-Duty Non-Locking Masts	1-5
1.4.3 Heavy-Duty Locking Masts	1-6
1.4.4 Super Heavy-Duty Non-Locking Masts	1-7
1.4.5 Super-Heavy-Duty Locking Masts	1-8
1.5 Major Components	1-9
1.5.1 Telescoping Mast	1-10
1.5.1.1 Hardware Bag	1-11
1.5.1.2 Drain Kit (P/N: 902982)	1-13
1.5.1.3 Magnetic Warning Kit	1-14
1.5.1.4 Mast Top Cover (P/N: 902989)	1-15
1.5.1.5 Identification Plate	1-16
1.5.1.6 Label Kit	1-16
1.5.2 Pneumatic System Options (Sold Separately)	1-17
1.5.2.1 Air Compressors	1-18
1.5.2.2 Filter Regulator Lubricator (P/N: 900484)	1-20
1.5.2.3 Filter Lubricator (P/N: 900634)	1-20
1.5.2.4 Solenoid Air Valve Kits	1-21
1.5.2.5 Hand Pump (P/N: 5050101)	1-22
1.5.3 Mounting Hardware Options (Sold Separately)	1-22
1.5.3.1 Base Plate Options	1-23
1.5.3.2 Support Bracket Options	1-26
1.5.3.3 Shelf Bracket	1-29
1.5.4 Payload Platforms and Stub Adaptors (Sold Separately)	1-29
1.5.5 Guy Line Kit Options (Sold Separately)	1-30
1.5.6 Additional Accessory Options	1-30
Section 2 Installation	2-1
2.1 Pre-Installation Check	2-1
2.2 Installation Equipment	2-2
2.3 Installation Hardware	2-3
2.4 Lift the Mast System	2-5
2.5 Unpack the Mast System	2-5
2.6 Installation Specifications	2-7
2.6.1 Mast Installation Specifications	2-8
2.6.2 Non-Rotating Base Plate Installation Specifications	2-10
2.6.3 Rotating Base Plate Installation Specifications	2-11
2.6.4 Turning Handle Assembly Installation Specifications	2-12
2.6.5 Internal Mounting Kit Installation Specifications	2-13

2.6.6 Support Bracket Assembly Installation Specifications	2-14
2.6.7 Shelf Bracket Assembly Installation Specifications	2-17
2.7 Mast Installation: Internal Mount	2-19
2.7.1 Internal Mount: Quick Summary	2-19
2.7.2 Internal Mount: Detailed Instructions	2-20
2.7.2.1 Select a Suitable Mounting Location.....	2-20
2.7.2.2 Begin Installation of the Internal Mounting Kit	2-21
2.7.2.3 Lower Mast through the Internal Mounting Kit	2-24
2.7.2.4 Attach the Base Plate to the Mast.....	2-24
2.7.2.5 Position the Mast.....	2-25
2.7.2.6 Secure the Base Plate to the Mounting Surface.....	2-25
2.7.2.7 Complete Installation of the Internal Mounting Kit	2-26
2.7.2.8 Finalize Installation of Mast System.....	2-28
2.8 Mast Installation: External Mount	2-29
2.8.1 External Mount: Quick Summary	2-29
2.8.2 External Mount: Detailed Instructions	2-30
2.8.2.1 Select a Suitable Mounting Location.....	2-30
2.8.2.2 Install the Shelf Bracket (Optional)	2-31
2.8.2.3 Attach the Base Plate to the Mast.....	2-31
2.8.2.4 Position the Mast.....	2-32
2.8.2.5 Install the External Support Bracket.....	2-32
2.8.2.6 Secure the Base Plate to the Mounting Surface.....	2-33
2.8.2.7 Install the Turning Handles (Rotatable Mast Systems Only)	2-34
2.8.2.8 Finalize Installation of Mast System.....	2-34
2.9 Complete Mast System Installation.....	2-35
2.9.1 Drain Kit Installation	2-36
2.9.2 Pneumatic System Installation.....	2-38
2.9.2.1 General Concepts	2-38
2.9.2.2 General Procedures	2-39
2.9.3 Magnetic Warning Kit Installation	2-42
2.10 Additional Accessory Installation.....	2-45
2.11 Test the Installation	2-46
2.12 Install Payload	2-46
Section 3 Operation	3-1
3.1 Pre-Operation Check	3-1
3.2 Operation Equipment	3-4
3.3 Mast Operation.....	3-4
3.3.1 Prepare the Mast System for Operation	3-5
3.3.2 Non-Locking Mast Operation	3-6
3.3.2.1 Extend the Mast	3-6
3.3.2.2 Rotate the Mast (Rotatable Mast Applications Only)	3-6
3.3.2.3 Lower the Mast.....	3-7
3.3.3 Locking Mast with T-Handle Yoke Assemblies Operation	3-8
3.3.3.1 Extend the Mast	3-8

3.3.3.2 Lower the Mast.....	3-13
3.3.4 Locking Mast with Trip Lines Operation.....	3-15
3.3.4.1 Extend the Mast	3-15
3.3.4.2 Lower the Mast.....	3-19
Section 4 Transportation	4-1
4.1 General Transportation	4-1
4.2 Shipping	4-2
Section 5 Maintenance	5-1
5.1 Pre-Maintenance Check.....	5-1
5.2 Maintenance Equipment	5-3
5.3 Spare Parts	5-3
5.4 Periodic Maintenance.....	5-4
5.4.1 Inspections	5-4
5.4.2 Cleaning and Lubrication	5-5
5.4.3 Weatherizing	5-6
5.5 Corrective Maintenance	5-7
5.5.1 Replace Seals on Standard-Duty Masts.....	5-7
5.5.2 Replace Seals, Expanders, and Yoke Assemblies on Heavy-Duty and Super-Heavy-Duty Masts.....	5-9
5.5.3 Replace Collar Bearing Strips.....	5-14
5.5.4 Replace Wear Rings	5-15
5.5.5 Replace Collar Inserts (Non-Locking Masts)	5-16
5.5.6 Replace Internal Bumpers	5-17
5.5.7 Replace External Bumpers	5-17
Section 6 Long-Term Storage	6-1
Section 7 Troubleshooting	7-1
Section 8 Reference.....	8-1
8.1 Extended Glossary of Terms.....	8-1
8.1.1 General Terms and Abbreviations	8-1
8.1.2 Mounting Position Terms	8-3
8.2 Reference Dimensional Information.....	8-4
8.2.1 Tube Diameters.....	8-4
8.2.2 Collar Information.....	8-5
8.3 Drawings	8-6

Table of Figures

Figure 1-1 Telescoping Masts (Not to Scale).....	1-10
Figure 1-2 Contents of Hardware Bag	1-12
Figure 1-3 Drain Kit (P/N: 902982)	1-13
Figure 1-4 Magnetic Warning Kit	1-14
Figure 1-5 Magnetic Warning Kit	1-15
Figure 1-6 Identification Plate (P/N: 902852).....	1-16
Figure 1-7 Identification Plate (P/N: 914098).....	1-16

Figure 1-8 Identification Plate (P/N: 902851) 1-16

Figure 1-9 Air Inlet Ports (Images Not to Scale) 1-17

Figure 1-10 Filter Regulator Lubricator (P/N: 900484) 1-20

Figure 1-11 Filter Lubricator (P/N: 900634) 1-20

Figure 1-12 Solenoid Air Valve Kits 1-21

Figure 1-13 Hand-Held Remote Controller (P/N: 912247)..... 1-21

Figure 1-14 Hand Pump (P/N: 5050001) 1-22

Figure 1-15 Non-Rotatable Base Plate (P/N: 902044 Shown) 1-23

Figure 1-16 Rotatable Base Plate Assembly 1-24

Figure 1-17 Turning Handles Assembly..... 1-24

Figure 1-18 Bottom of Rotatable Super-Heavy-Duty Mast (P/N: 909426 Shown)..... 1-24

Figure 1-19 Field Mount Base Plate (Base Plate P/N: 903403 Shown) 1-25

Figure 1-20 Dog Dish Base Plate (P/N: 4201401 Shown) 1-25

Figure 1-21 Internal Mounting Kit for Standard-Duty and Heavy-Duty Masts (P/N: 905733 Shown)..... 1-26

Figure 1-22 Internal Mounting Kit for Non-Rotating Super-Heavy-Duty Masts (P/N: 910784 Shown) ... 1-27

Figure 1-23 Internal Mounting Kit for Rotating Super-Heavy-Duty Masts (P/N: 4915901 Shown) 1-27

Figure 1-24 External Support Bracket (P/N: 4443601 Shown) 1-28

Figure 1-25 Super-Heavy-Duty External Support Brackets 1-28

Figure 1-26 Shelf Bracket (P/N: 4434101 Shown)..... 1-29

Figure 1-27 Payload Platform (P/N: 915343 Shown)..... 1-29

Figure 1-28 Stub Adaptor (P/N: 910353 Shown) 1-29

Figure 2-1 Shipping Crate 2-6

Figure 2-2 Hoist the Mast..... 2-6

Figure 2-3 Mast Installation Specifications (Not to Scale) 2-9

Figure 2-4 Non-Rotating Base Plate Installation Specifications (P/N: 902491 Shown)..... 2-10

Figure 2-5 Rotating Base Plate Installation Specifications (P/N: 902492 Shown)..... 2-11

Figure 2-6 Turning Handle Assembly Installation Specifications 2-12

Figure 2-7 Internal Mounting Kit Hardware Installation Specifications 2-13

Figure 2-8 Support Bracket Assembly (Standard and Heavy-Duty) Installation Specifications 2-14

Figure 2-9 Support Bracket Assembly (Super-Heavy-Duty) Installation Specifications 2-15

Figure 2-10 Support Bracket Assembly (Super-Heavy-Duty) Installation Specifications 2-16

Figure 2-11 Shelf Bracket Installation Specifications..... 2-18

Figure 2-12 Internal Mount Installation 2-19

Figure 2-13 Roof Line Location (Not to Scale)..... 2-20

Figure 2-14 Internal Mounting Kit for Standard-Duty and Heavy-Duty Masts (P/N: 905733 Shown)..... 2-21

Figure 2-15 Internal Mounting Kit for Super-Heavy-Duty Masts (P/N: 910784 Shown) 2-21

Figure 2-16 Fasten Assembly Together..... 2-22

Figure 2-17 Fasten Assembly Together..... 2-23

Figure 2-18 Fasten Assembly Together..... 2-26

Figure 2-19 External Mount Installation 2-29

Figure 2-20 Mounting Hardware Location (Not to Scale) 2-30

Figure 2-21 External Support Bracket P/N: 4894901 Installation 2-32

Figure 2-22 Internal Mount General Layout 2-35

Figure 2-23 External Mount General Layout..... 2-35

Figure 2-24 Drain Kit (P/N: 902982)	2-36
Figure 2-25 Drain Kit Installation.....	2-37
Figure 2-26 General Pneumatic System Layout	2-40
Figure 2-27 Pneumatic System Installation	2-41
Figure 2-28 Magnet.....	2-42
Figure 2-29 Magnetic Switch Assembly Attached to Base Tube	2-42
Figure 2-30 Wire the Magnetic Switch Assembly Kit	2-43
Figure 2-31 Wire the Magnetic Switch Assembly Kit	2-44
Figure 2-32 Relay and Magnetic Switch Assembly Wiring	2-44
Figure 3-1 Locking Screws (P/N: 5074601 Shown).....	3-6
Figure 3-2 Bottom of Rotatable Super-Heavy-Duty Mast (P/N: 909426 Shown).....	3-7
Figure 3-3 Sample of Guy Line Attachment on a Mast with Cable Guides	3-9
Figure 3-4 Sample of Laying Out Guy Lines.....	3-10
Figure 3-5 Latch Lever Positions	3-11
Figure 3-6 Locking Screws (P/N: 5074601 Shown).....	3-12
Figure 3-7 Bottom of Rotatable Super-Heavy-Duty Mast (P/N: 909426 Shown).....	3-12
Figure 3-8 Vertically Align the Mast	3-13
Figure 3-9 Sample of Guy Line Attachment on a Mast with Cable Guides	3-15
Figure 3-10 Cable Guide on Collar	3-16
Figure 3-11 Sample of Laying Out Guy Lines and Trip Lines.....	3-16
Figure 3-12 Latch Lever Positions	3-17
Figure 3-13 Vertically Align the Mast	3-18
Figure 5-1 Application Bottle and Gallon of Will-Burt Non-Toxic Pneumatic Mast Antifreeze	5-6
Figure 5-2 Seal Replacement	5-8
Figure 5-3 Locking Collar Assembly	5-10
Figure 5-4 Seal Area (Heavy-Duty and Super-Heavy-Duty).....	5-11
Figure 5-5 Seal Replacement	5-12
Figure 5-6 Bearing Strip and Keyway	5-14
Figure 5-7 Replacing Wear Rings.....	5-15
Figure 5-8 Replacing Collar Inserts	5-16
Figure 5-9 Replacing Internal Bumpers	5-17
Figure 5-10 Replacing External Bumpers.....	5-18
Figure 8-1 Tube Diameters	8-4
Figure 8-2 Collar Information	8-6

Table of Tables

Table 1-1 Standard-Duty Non-Locking Mast Part and Model Numbers	1-4
Table 1-2 Standard-Duty Non-Locking Mast Specifications	1-4
Table 1-3 Heavy-Duty Non-Locking Mast Part and Model Numbers.....	1-5
Table 1-4 Heavy-Duty Non-Locking Mast Specifications.....	1-5
Table 1-5 Heavy-Duty Mast Part and Model Numbers	1-6
Table 1-6 Heavy-Duty Locking Mast Specifications	1-6
Table 1-7 Super-Heavy-Duty Non-Locking Mast Part and Model Numbers.....	1-7

Table 1-8 Super-Heavy-Duty-Duty Non-Locking Mast Specifications	1-7
Table 1-9 Super-Heavy-Duty Mast Part and Model Numbers	1-8
Table 1-10 Super-Heavy-Duty Locking Mast Specifications.....	1-8
Table 1-11 Magnetic Warning Kits.....	1-14
Table 1-12 Air Compressor Specifications.....	1-18
Table 1-13 Additional Accessory Options	1-30
Table 2-1 Equipment Recommended for Installation.....	2-2
Table 2-2 Hardware for Internal Mount Application Installation	2-3
Table 2-3 Hardware for External Mount Application Installation.....	2-4
Table 2-4 Mast Installation Specifications.....	2-8
Table 2-5 Non-Rotating Base Plate Installation Specifications.....	2-10
Table 2-6 Rotating Base Plate Installation Specifications	2-11
Table 2-7 Turning Handle Assembly Installation Specifications	2-12
Table 2-8 Internal Mounting Kit (Roof Flange and Roof Ring) Installation Specifications	2-13
Table 2-9 Support Bracket Assembly (Standard and Heavy-Duty) Installation Specifications.....	2-14
Table 2-10 Shelf Bracket Assembly Specifications	2-17
Table 3-1 Equipment Recommended for Operation	3-4
Table 5-1 Equipment Recommended for Maintenance	5-3
Table 5-2 Inspections.....	5-4
Table 7-1 Troubleshooting	7-1
Table 8-1 Tube Diameters	8-4
Table 8-2 Standard-Duty Collar Information	8-5
Table 8-3 Heavy-Duty Collar Information.....	8-5
Table 8-4 Super-Heavy-Duty Collar Information.....	8-6

Safety Summary

This section describes safety information for the Pneumatic Mast System. These are recommended precautions that personnel must understand and apply throughout installation, operation, transportation, maintenance, storage, and troubleshooting. Be sure to read and understand the entire manual and contact The Will-Burt Company with any questions before performing any procedure outlined in this manual.

Signal Word Definitions

Per the ANSI Z535.4 standard, the following signal words and definitions are used to indicate hazardous situations:

DANGER

DANGER indicates an imminently hazardous situation that, if not avoided, will result in death or serious injury.

WARNING

WARNING indicates a potentially hazardous situation that, if not avoided, could result in death or serious injury.

CAUTION

CAUTION indicates a potentially hazardous situation that, if not avoided, may result in minor or moderate injury. It is also used to alert against unsafe practices.

General Safety Instructions

The following are general safety precautions that are not related to any specific procedures. These are recommended precautions that personnel must understand and apply throughout installation, operation, maintenance, and troubleshooting.

DANGER

Electrocution Hazard! Contact with high voltage will result in death or serious injury. Observe general safety precautions for handling equipment using high voltage. Do not locate or operate mast near electrical lines, cables or other unwanted sources of electricity. Be sure to allow sufficient clearance on all sides of the mast to allow for side sway. Do not operate mast in lightning. Be certain electrical cables are undamaged and properly terminated. Always disconnect power before performing service, repair or test operations.

WARNING

Safety Instruction – Trained Personnel Only! Death or serious injury could result if proper inspection, installation, operation and maintenance procedures are not observed. Installation, operation and maintenance to be performed by trained and authorized personnel only. Proper eye protection should be worn when servicing the mast.

⚠ WARNING

Safety Instruction – Read Manual! Failure to follow operating instructions could result in death or serious injury. Read and understand the operator's manual before using the mast.

⚠ WARNING

Safety Equipment! Helmets or hard hats, eye protection, gloves, and safety shoes must be properly worn while working in the deployment area. Death or serious injury could result if proper safety equipment is not properly worn.

⚠ WARNING

Tip Over Hazard! Mast tip over could result in death or serious injury. Do not operate in high winds. Be certain mast is level, stable, and secure before and during installation, operation, maintenance, and transportation. Operate on level ground only. Stand clear of mast and mast payload during operation. Be certain mast is level and secure before and during installation, operation and maintenance. Before operating, the base section shall be within:

- 5° of vertical for Standard-Duty and Heavy-Duty masts with extended heights ≤ 60 feet
- 3° of vertical for Heavy-Duty masts with extended heights > 60 feet
- 3° for all Super-Heavy-Duty masts

⚠ WARNING

Safety Instruction – Resuscitation Alert! Personnel working with or near high voltages should be familiar with modern methods of resuscitation. Such information may be obtained from the Bureau of Medicine and Surgery.

⚠ WARNING

Health and Safety Hazard! Solvent used to clean parts is potentially dangerous. Follow solvent manufacturer's safety procedures and recommendations. Avoid inhalation of fumes and also prolonged contact to skin. Death or serious injury could occur if solvents are not handled properly.

Specific Safety Instructions

The following are safety precautions that are related to specific procedures and therefore appear elsewhere in this publication for emphasis. These are recommended precautions that personnel must understand and apply during specific phases of installation, operation and maintenance.

⚠ WARNING

Mounting Structure Hazard! Before installation, ensure the mounting structure is capable of resisting forces generated from all loading and environmental conditions, including, but not limited to, Mast System size and weight, payload size and weight, sail size, wind speed, Guy Line arrangement, support bracket or roof line location and base plate assembly. Mounting the Mast System into a structure unable to resist the forces generated from the customer-specific loading scenario could result in death or serious injury, and could damage the Mast System.

⚠ WARNING

Lifting Hazard – Intended Use! The mast is intended to lift a specific payload for lighting, surveillance or communication use only. Any other use without written consent is prohibited and could cause death or serious injury. Do not use mast to lift personnel. Do not exceed specified payload capacity. Large payload wind sail areas can reduce payload capacity. Consult Will-Burt engineering.

⚠ WARNING

Crush Hazard – Hoist Failure! Use extreme caution while installing the Base Plate to the mast. Be certain mast is properly secured during installation of Base Plate. Death or serious injury could occur if hoist fails or mast slips suddenly.

⚠ WARNING

Crush Hazard – Mast Failure! Death or serious injury could result if mast fails suddenly. Do not stand directly beneath the mast or its payload. Be certain payload is properly installed and secured. Wear head protection gear.

⚠ WARNING

Burst Hazard! Over-pressurizing mast will trip safety valve and could result in death or serious injury. Do not exceed maximum operating pressure of 35 psi (241 kPa) for Heavy-Duty and Super-Heavy-Duty masts. Do not exceed maximum operating pressure of 20 psi (138 kPa) for Standard-Duty masts. Keep personnel clear of safety valve exhaust direction.

⚠ WARNING

Mast Extension Hazard! Extending mast into obstructions could result in death or serious injury and could render the mast inoperable and partially extended. Before applying power and operating the mast, be certain there is sufficient clearance above and to all sides of the expected location of the fully extended mast and payload. Keep all persons clear of mast and mast extension. Do not lean directly over the mast.

⚠ WARNING

Impact Hazard! The mast should operate smoothly during extension and retraction. If erratic mast motion is observed during extension or retraction that results in impact loading between the tube and the tube collar (mechanical travel stop), cease use of the mast and contact Will-Burt service. Operating a mast with erratic mast tube motion over time could result in mast separation and could cause damage to the mast or result in death or serious injury.

⚠ WARNING

Fire Hazard! Cleaning solvent, used for maintenance, is flammable and can be explosive resulting in death or serious injury. Do not smoke. Use cleaning solvent in a well-ventilated area. Keep cleaning solvent away from ignition sources. Always store cleaning solvent in the proper marked container.

⚠ WARNING

Pinch Point Hazard! Moving parts can crush and cut resulting in death or serious injury. Keep clear of moving parts while operating mast.

⚠ WARNING

Relocation Hazard! Relocating the mast during operation or after extension could result in death or serious injury. Do not relocate the mast during operation or while extended. This applies especially to masts mounted to vehicles. Operate the mast only if the vehicle is stationary and the vehicle engine is off. Do not install mast on a vehicle without installing the Magnetic Warning Kit.

⚠ WARNING

Safety Instruction – Observe Proper Procedures! Use extreme caution while lifting the Mast System and when Mast System is suspended to avoid injury and equipment damage. Be certain the Mast System is properly secured. All operators should be aware of and follow the applicable local, regional, and national standards and codes of practice for slinging and transporting equipment. Never lift Mast System over people. Ensure lifting equipment including, but not limited to, lifting straps and hoist, are capable of handling the forces generated from lifting the system. Observe manufacturer instructions on lifting equipment. Death or serious injury could result if proper procedures are not followed.

⚠ WARNING

Safety Instruction – Mounting Instructions! Before operation, be certain the mounting structure is capable of resisting forces generated from all loading and environmental conditions including, but not limited to payload size and weight, sail size, and wind and ice loading. The mounting hardware must include proper means to resist vibration loosening such as thread-locking compound or locking hardware. Mounting the payload into a structure unable to resist the forces generated from the customer-specific loading scenario could result in death or serious injury, and could damage the mast and mounting structure.

⚠ WARNING

Safety Instruction – Operation! At all times prior to mast operation, ensure:

- The mast area is free of personnel and mechanical obstruction
- All electrical cables are undamaged and properly terminated
- The operator has full view of the mast during use
- Any transit tie-downs on the payload have been removed
- The vehicle is not moving
- The Magnetic Warning Kit is installed on a vehicle
- The area above the mast is free of mechanical obstructions and electrical power lines
- The mast Base Tube angle is within 5° of vertical for Standard-Duty masts and Heavy-Duty masts with extended heights up to 60 feet, and within 3° of vertical for Heavy-Duty masts with extended heights greater than 60 feet and Super-Heavy-Duty masts

⚠ WARNING

Safety Instruction – Operation! For outdoor use only. Do not use in areas that have been classified as hazardous as defined in Article 500 of the National Electric Code.

⚠ WARNING

Safety Instruction – Keep Clear! Keep personnel clear of the Mast System during operation.

⚠ WARNING

Safety Instruction – Potential Air Contaminants! If internally mounted, air from the mast will discharge into the vehicle while the Drain Cock is open.

⚠ WARNING

Safety Instruction – Rapid Release of Air Pressure! If the Mast System air pressure is not fully discharged prior to removing the Air Hoses, a rapid release of air pressure will occur causing a need for hearing and eye protection.

⚠ WARNING

Safety Instruction – Power! Make sure all power has been disconnected prior to performing maintenance.

⚠ CAUTION

Equipment Damage – Qualified Personnel! All persons installing and maintaining this equipment should be suitably qualified and work to local, regional, and national standards and codes of practice.

⚠ CAUTION

Equipment Damage – Forces! Before unloading the system, be certain the unloading region is capable of resisting forces generated from unloading the system including but not limited to system weight. Ensure the unloading region is level and has sufficient room and strength to hold the system. If the unloading region is incapable of meeting the requirements of the system, damage to the system and/or unloading region could occur.

⚠ CAUTION

Safety Instruction – Guy Anchors! When using Guy Lines, the installer shall verify the Guy Anchor point strength is adequate to support the Guy Line forces.

⚠ CAUTION

Safety Instruction – Air Control Valve! Improper positioning and operation of Air Control Valve can result in moderate injury or equipment damage. Air Control Valve must be mounted in a location where the operator has full view of the mast, but does not make contact with the mast during operation. Only use a Hold-To-Run type Air Control Valve or switch. The Air Control Valve shall be normally open when the mast is in transit or not in use.

⚠ CAUTION

Safety Instruction – Follow Procedures! Failure to follow Drain Kit installation instructions could damage the mast and render the mast inoperable. Read and understand the installation instructions before installing the Drain Kit.

⚠ CAUTION

Equipment Damage – Band Clamp Fasteners! Do not overtighten the Band Clamp fasteners. Overtightening may damage the Base Tube causing the mast tubes to stick.

⚠ CAUTION

Equipment Damage – Deviation! Deviation from standard operating conditions and procedures could cause system failure.

⚠ CAUTION

Safety Instruction – Installation! At all times while using pipe and hose during installation, recognize that:

- Pipe and hose should be routed, mounted and restrained to protect from damage
- Do not use second hand piping for installation
- Do not bend air pipe and hose at a radius less than specified by the manufacturer
- Pipes should be marked to avoid hazards from incorrect connection
- The exhaust should be fitted with a silencer and be directed away from personnel
- When routing piping, install in such a way as to minimize torsion on the joints
- Mounting of air pipe and hose shall be done with tools and in such a way to prevent air pipe and hose from easily disconnecting from the mast

⚠ CAUTION

Safety Instruction – Roof Access! If mast will be mounted to a vehicle, the operator must provide safe means to access the roof of the vehicle during installation and maintenance.

⚠ CAUTION

Safety Instruction – Mast Access! The operator must provide safe means to access the top of the mast during installation and removal of the payload.

⚠ CAUTION

Lifting Hazard – Manually Lifting! Manually lifting over 55 lb. (25 kg) is prohibited. In the UK, all lifting equipment must be thoroughly examined annually by a competent person according to the Lifting Operations and Lift Equipment Regulations 1998. Equivalent regulations exist in other EU states.

⚠ CAUTION

Equipment Damage – Obstruction! Check for and remove any objects that might obstruct motion, cause binding, or hinder function of the Mast System. Hitting obstructions will cause damage to the mast.

⚠ CAUTION

Entanglement Hazard! Tangled cables can cause equipment damage. Ensure control cables, Guy Lines, and Trip Lines are not tangled and are free to pay out as mast is extended.

⚠ CAUTION

Pressurized Device Hazard! Mast disassembly prior to depressurization may release pressurized air jet. Completely lower the mast, depressurize and shut down power before disassembly. Ensure an over-pressurization safety valve is installed in the system.

⚠ CAUTION

Frozen Water Hazard! Water freezing inside mast or air fittings may render mast inoperable and cause major equipment damage. Open Drain Cock, when mast is not in operation. The Drain Cock shall be installed at the lowest position in the Pneumatic System. Cover locking masts when not in use. Non-locking masts stored outdoors should be covered if possible. Will-Burt P/N: 902989 is available from Will-Burt.

Symbols

The following are symbols that are used with the system and their meaning. Symbols are provided for quick reference only. Read the label information with the symbols for additional safety information. Contact The Will-Burt Company with any questions before performing any procedure outlined in this manual.



This symbol indicates an electrocution hazard.



This symbol indicates a tip-over hazard.



This symbol indicates a pinch point hazard.



This symbol indicates a burst hazard.



This symbol indicates a general hazard. In this unit, this symbol indicates a frozen water hazard.



This symbol is used to remind operators to read the operator's manual. Failure to follow operating instructions could result in death or serious injury.



This symbol is used to indicate the center of gravity (COG) of a fully nested mast.

Section 1 Introduction

Review this manual in its entirety. Contact The Will-Burt Company with any questions before performing any procedure outlined in this manual. The views depicted in this manual are provided for clarification and are subject to change without notice. Views are not to scale.

This manual describes installation, operation, transportation, maintenance, storage, and troubleshooting procedures for the Pneumatic Mast System. These procedures assume the use of standard catalog Mast Systems with a clear anodized finish. Procedures and characteristics for Mast Systems customized to meet customer-specific needs may vary.

This manual is for the following pneumatic masts:

- Standard-Duty Non-Locking Pneumatic Masts
- Heavy-Duty Non-Locking and Locking Pneumatic Masts (HDNL and HDL)
- Super-Heavy-Duty Non-Locking and Locking Pneumatic Masts (SHDNL and SHDL)

This manual is not for the following pneumatic masts:

- Ultra-Heavy-Duty Pneumatic Masts (UHD)
- Internally Wired Pneumatic Masts (IWM)
- Yacht Masts
- Low Profile Pneumatic Masts
- Night Scan[®], Inflexion[™], and InflexionPlus[™] Masts

See www.willburt.com for information on these and other Will-Burt products.

A typical Pneumatic Mast System consists of:

- A Telescoping Mast
- A Pneumatic System
- Mounting Hardware
- Optional Accessories

The pneumatic mast is designed to lift a specific payload for lighting, surveillance, or communication use only. Do not use mast to lift personnel. Contact The Will-Burt Company with any questions on the intended use.

1.1 Safety Precaution Notification

Refer to the Safety Summary for precautions to be observed while installing, operating, or maintaining this equipment.

1.2 Manual Organization

This manual is organized into the following sections:

Section 1 Introduction

Section 2 Installation

Section 3 Operation

Section 4 Transportation

Section 5 Maintenance

Section 6 Long-Term Storage

Section 7 Troubleshooting

Section 8 Reference

1.3 Definitions of Terms

Throughout this manual, the following terms are used:

- “Mast” to refer to the telescoping pneumatic mast
- “Mast System” to refer to the entire Pneumatic Mast System (telescoping mast, pneumatic system, mounting hardware, and additional accessories)
- “Payload” to refer to the object or equipment being raised by the mast to an operational height

See Section 8.1 for an Extended Glossary of Terms used within this manual. The Extended Glossary of Terms includes:

- General Terms and Abbreviations (Section 8.1.1)
- Mounting Position Terms (Section 8.1.2)

1.4 Specifications

This section describes specifications for pneumatic masts as follows:

- Standard-Duty Non-Locking Masts (Section 1.4.1)
- Heavy-Duty Non-Locking Masts (Section 1.4.2)
- Heavy-Duty Locking Masts (Section 1.4.3)
- Super Heavy-Duty Non-Locking Masts (Section 1.4.4)
- Super-Heavy-Duty Locking Masts (Section 1.4.5)

The model numbers listed in this section are for catalog masts with a clear anodized finish only. Masts with other heights, capacities, and finishes are available. For more information on additional mast sizes, capabilities, and finishes, see www.willburt.com.

1.4.1 Standard-Duty Non-Locking Masts

This section lists specifications for Standard-Duty non-locking masts.

Table 1-1 Standard-Duty Non-Locking Mast Part and Model Numbers

P/N *	M/N
906021	5-20
906023	6-27
906025	7-34
906027	8-30
* Part numbers listed for masts with a clear anodize finish only. Additional finishes and options available.	

Table 1-2 Standard-Duty Non-Locking Mast Specifications

M/N	Payload Capacity	Extended Height	Nested Height	Approx. Mast Weight	No. of Tubes	Tube Diameter
5-20	70 lb.	20'	5' 4"	45 lb.	6	5-2.5"
	31.8 kg	6.10 m	1.63 m	21 kg		127-64 mm
6-27	40 lb.	26' 10"	6'	54 lb.	7	5-2"
	18.1 kg	8.18 m	1.83 m	25 kg		127-51 mm
8-30	100 lb.	29' 11"	8'	64 lb.	5	5-3"
	45.4 kg	9.12 m	2.44 m	29 kg		127-76 mm
7-34	40 lb.	33' 10"	7'	67 lb.	7	5-2"
	18.1 kg	10.31 m	2.13 m	31 kg		127-51 mm
Note: <ol style="list-style-type: none"> 1. Tube Diameter listed as Base Tube Diameter – Top Tube Diameter 2. Dimensions and specifications provided are for reference only and are not intended for vehicle design purposes 3. Specifications may be subject to change without notice 4. Payload Capacity assumes: <ul style="list-style-type: none"> • 12 inch maximum offset payload from mast centerline • Mast deployment angle is 0° to 5° • Operating temperature is -20° to 60°C • Mast maximum pressure of 20 PSIG (1.4 Bar) • Not applicable to internally wired masts 						

1.4.2 Heavy-Duty Non-Locking Masts

This section lists specifications for heavy-duty non-locking masts.

Table 1-3 Heavy-Duty Non-Locking Mast Part and Model Numbers

P/N *	M/N	P/N *	M/N
906029	6-25	906037	8.5-52
906033	7-30	906039	9.5-56
906035	7-42	906041	9-58
906215	8.5-48		

* Part numbers listed for masts with a clear anodize finish only. Additional finishes and options available.

Table 1-4 Heavy-Duty Non-Locking Mast Specifications

M/N	Payload Capacity	Extended Height	Nested Height	Approx. Mast Weight	No. of Tubes	Tube Diameter
6-25	200 lb.	25'	5' 10"	110 lb.	6	6.75-3"
	90.7 kg	7.62 m	1.78 m	50 kg		171-76 mm
7-30	200 lb.	29' 1"	6' 8"	125 lb.	6	6.75-3"
	90.7 kg	8.86 m	2.03 m	57 kg		171-76 mm
7-42	200 lb.	41' 2"	7' 1"	235 lb.	9	9-3"
	90.7 kg	12.55 m	2.16 m	107 kg		229-76 mm
8.5-48	300 lb.	48'	8' 6"	275 lb.	8	9-3.75"
	136.1 kg	14.63 m	2.59 m	125 kg		229-95 mm
8.5-52	200 lb.	52'	8' 4"	266 lb.	9	9-3"
	90.7 kg	15.85 m	2.54 m	121 kg		229-76 mm
9.5-56	300 lb.	56' 2"	9' 6"	296 lb.	8	9-3.75"
	136.1 kg	17.12 m	2.90 m	135 kg		229-95 mm
9-58	200 lb.	58'	9'	290 lb.	9	9-3"
	90.7 kg	17.68 m	2.74 m	132 kg		229-76 mm

Note:

1. Tube Diameter listed as Base Tube Diameter – Top Tube Diameter
2. Dimensions and specifications provided are for reference only and are not intended for vehicle design purposes
3. Specifications may be subject to change without notice
4. Payload Capacity assumes:
 - 12 inch maximum offset payload from mast centerline
 - Mast deployment angle is 0° to 5°
 - Operating temperature is -20° to 60°C
 - Mast maximum pressure of 35 PSIG (2.4 Bar)
 - Not applicable to internally wired masts

1.4.3 Heavy-Duty Locking Masts

This section lists specifications for Heavy-Duty locking masts.

Table 1-5 Heavy-Duty Mast Part and Model Numbers

P/N *	M/N
906043	7-30
906045	7-42
906051	10-60
906053	14.5-80
906055	17-100
906057	20-134

* Part numbers listed for masts with a clear anodize finish only. Additional finishes and options available.

Table 1-6 Heavy-Duty Locking Mast Specifications

M/N	Payload Capacity	Extended Height	Nested Height	Approx. Mast Weight	No. of Tubes	Tube Diameter	Collar Type	Guying Required
7-30	200 lb.	29' 1"	7'	125 lb.	6	6.75–3"	Locking T-Handles	Optional
	90.7 kg	8.86 m	2.13 m	57 kg		171–76 mm		
7-42	200 lb.	41' 3"	7' 9"	235 lb.	9	9–3"	Locking T-Handles	Optional
	90.7 kg	12.57 m	2.36 m	107 kg		229–76 mm		
10-60	300 lb.	59' 9"	10' 1"	330 lb.	8	9–3.75"	Locking T-Handles	Optional
	136.1 kg	18.21 m	3.07 m	150 kg		229–95 mm		
14.5-80	400 lb.	79' 9"	14' 3"	416 lb.	7	9–4.5"	Locking Trip Lines	4 Way
	181.4 kg	24.31 m	4.34 m	189 kg		229–114 mm		4 Level
17-100	400 lb.	99' 9"	17' 2"	480 lb.	7	9–4.5"	Locking Trip Lines	4 Way
	181.4 kg	30.40 m	5.23 m	218 kg		229–114 mm		4 Level
20-134	300 lb.	133' 9"	20' 2"	600 lb.	8	9–3.75"	Locking Trip Lines	4 Way
	136.1 kg	40.77 m	6.15 m	273 kg		229–95 mm		5 Level

Note:

1. Tube Diameter listed as Base Tube Diameter – Top Tube Diameter
2. Dimensions and specifications provided are for reference only and are not intended for vehicle design purposes
3. Specifications may be subject to change without notice
4. Payload Capacity assumes:
 - 12 inch maximum offset payload from mast centerline
 - Mast deployment angle is 0° to 5° for extended heights 60' and below. 0° to 3° for heights > 60'.
 - Operating temperature is -20° to 60°C
 - Mast maximum pressure of 35 PSIG (2.4 Bar)
 - Not applicable to internally wired masts

1.4.4 Super Heavy-Duty Non-Locking Masts

This section lists specifications for Super-Heavy-Duty non-locking masts.

Table 1-7 Super-Heavy-Duty Non-Locking Mast Part and Model Numbers

P/N *	M/N
915507	10-38
710904800	12-48
* Part numbers listed for masts with a clear anodize finish only. Additional finishes and options available.	

Table 1-8 Super-Heavy-Duty-Duty Non-Locking Mast Specifications

M/N	Payload Capacity	Extended Height	Nested Height	Approx. Mast Weight	No. of Tubes	Tube Diameter
10-38	1200 lb.	38'	10'	400 lb.	5	11.25–7.5"
	544.3 kg	11.58 m	3.05 m	181 kg		285–192 mm
12-48	1200 lb.	47' 11"	12'	475 lb.	5	11.25–7.5"
	544.3 kg	14.61 m	3.66 m	215 kg		285–192 mm
Note: <ol style="list-style-type: none"> 1. Tube Diameter listed as Base Tube Diameter – Top Tube Diameter 2. Dimensions and specifications provided are for reference only and are not intended for vehicle design purposes 3. Specifications may be subject to change without notice 4. Payload Capacity assumes: <ul style="list-style-type: none"> • 12 inch maximum offset payload from mast centerline • Mast deployment angle is 0° to 3° • Operating temperature is -20° to 60°C • Mast maximum pressure of 35 PSIG (2.4 Bar) • Not applicable to internally wired masts 						

1.4.5 Super-Heavy-Duty Locking Masts

This section lists specifications for Super-Heavy-Duty locking masts.

Table 1-9 Super-Heavy-Duty Mast Part and Model Numbers

P/N *	M/N
909959	9-50
909426	10.3-60
910916	10.8-76
912970	15.7-100
* Part numbers listed for masts with a clear anodize finish only. Additional finishes and options available.	

Table 1-10 Super-Heavy-Duty Locking Mast Specifications

M/N	Payload Capacity	Extended Height	Nested Height	Approx. Mast Weight	No. of Tubes	Tube Diameter	Collar Type	Guying Required
9-50	530 lb.	50' 5"	9' 2"	500 lb.	8	11.25–5.25"	Locking T-Handles	Optional
	240.4 kg	15.37 m	2.79 m	227 kg		286–134 mm		
10.3-60	530 lb.	60' 6"	10' 5"	500 lb.	8	11.25–5.25"	Locking T-Handles	Optional
	240.4 kg	18.44 m	3.18 m	227 kg		286–134 mm		
10.8-76	300 lb.	76' 2"	10' 9"	536 lb.	10	11.25–3.75"	Locking T-Handles and Trip Lines	4 Way
	136.1 kg	23.22 m	3.28 m	245 kg		286–96 mm		1 Level
15.7-100	530 lb.	100'	15' 8"	790 lb.	8	11.25–5.25"	Locking Trip Lines	4 Way
	240.4 kg	30.48 m	4.78 m	361 kg		286–134 mm		4 Level

Note:

1. Tube Diameter listed as Base Tube Diameter – Top Tube Diameter
2. Dimensions and specifications provided are for reference only and are not intended for vehicle design purposes
3. Specifications may be subject to change without notice
4. Payload Capacity assumes:
 - 12 inch maximum offset payload from mast centerline
 - Mast deployment angle is 0° to 5° for extended heights 60' and below. 0° to 3° for heights > 60'.
 - Operating temperature is -20° to 60°C
 - Mast maximum pressure of 35 PSIG (2.4 Bar)
 - Not applicable to internally wired masts

1.5 Major Components

This section describes major components of a Mast System assuming the use of standard catalog Mast Systems. Characteristics of components customized to meet customer-specific needs may vary. If necessary, contact The Will-Burt Company for additional details.

Major components of the pneumatic mast include:

- Telescoping Mast
 - Hardware Bag
 - Drain Kit (P/N: 902982)
 - Magnetic Warning Kit
 - Mast Top Cover (P/N: 902989)
 - Identification Plate
 - Label Kit
- Pneumatic System Options (Sold Separately)
 - Air Compressors
 - Filter Regulator Lubricator (P/N: 900484)
 - Filter Lubricator (P/N: 900634)
 - Solenoid Air Valve Kit
 - Hand Pump (P/N: 5050101)
- Mounting Hardware Options (Sold Separately)
 - Base Plate Options
 - Non-Rotatable Base Plates
 - Rotatable Hardware Kits
 - Field Mount and Dog Dish Base Plates
 - Support Bracket Options
 - Internal (Roof) Mounting Kit
 - External Support Bracket
 - Shelf Bracket
- Payload Platforms and Stub Adaptors (Sold Separately)
- Guy Line Kit Options (Sold Separately)
- Additional Accessories Options (Sold Separately)

1.5.1 Telescoping Mast

There are three major types of telescoping mast described in this manual (Figure 1-1):

- Non-locking masts which must remain pressurized to support the payload at an extended height. Allowing depressurization will allow the mast and payload to lower.
- Locking masts with T-Handle Yoke Assemblies which are depressurized once the desired tubes are raised and locked into position.
- Locking masts with Trip Lines which allow the mast to be guyed as it is being extended, and are depressurized once the desired tubes are raised and locked into position.

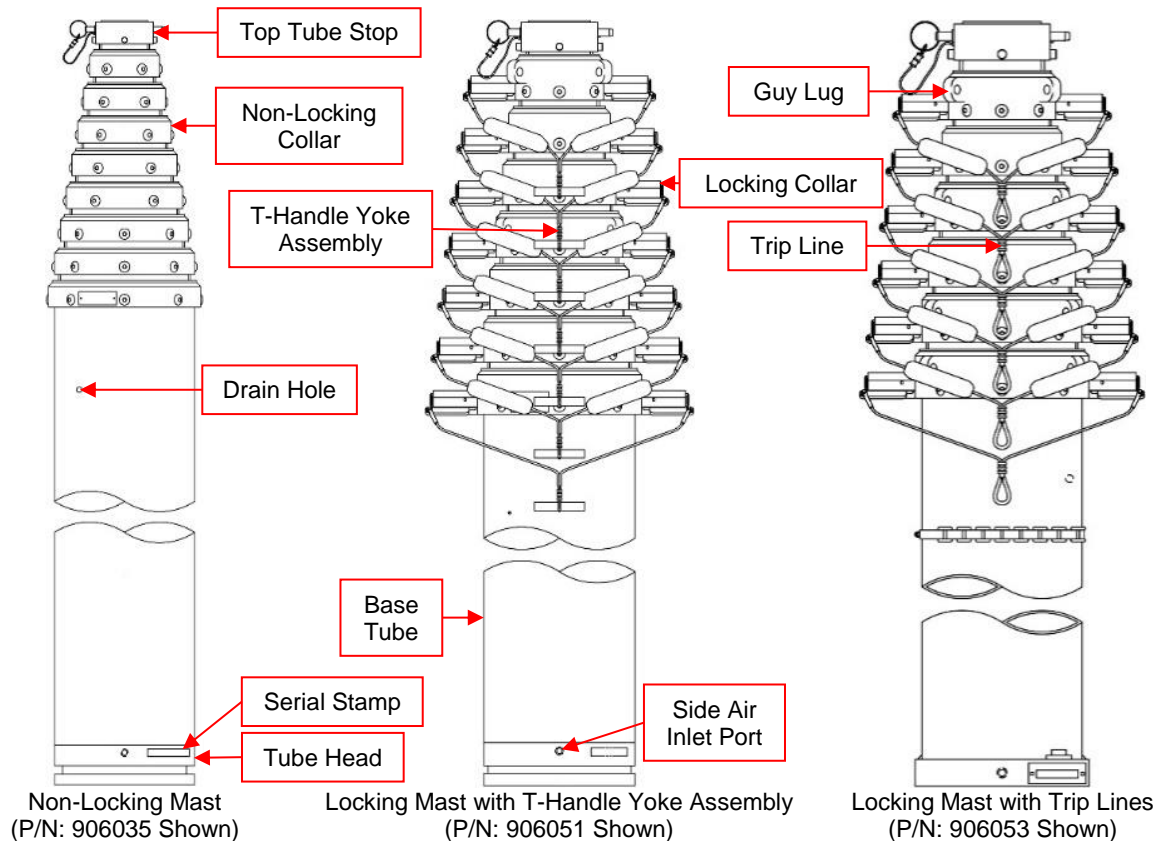

Figure 1-1 Telescoping Masts (Not to Scale)

The telescoping mast:

- Is the structure used to raise the payload to an operational height
- Consists of concentric, nesting mast tubes
- Extends and retracts pneumatically
- Can be non-locking or locking
- Can be non-rotating or rotating

The mast has:

- Collars fitted to the top end of each tube except the Top Tube which is fitted with a Top Tube Stop
- Two rectangular keys along each tube, except the Base Tube. These keys align with keyways in the next larger adjacent tube's collar and are used to establish azimuth (rotational) integrity between the tubes.

Items shipping with the mast include:

- Hardware Bag
- Drain Kit (P/N: 902982)
- Magnetic Warning Kit
- Mast Top Cover (P/N: 902989)
- Identification Plate (Ships installed on mast)
- Label Kit (Labels ship installed on the mast and with the manual)

1.5.1.1 Hardware Bag

The Mast System includes a 4 x 6 inch (102 x 152 mm) plain cloth Hardware Bag. Depending on the specific installation application, all hardware may not be used.

Standard-Duty masts ship standard with Hardware Bag P/N: 913963.

Heavy-Duty and Super-Heavy-Duty masts ship standard with Hardware Bag P/N: 902853.

The contents of the Hardware Bag (Figure 1-2) are used to:

- Secure the Base Plate to the mast:
 - (4) Screw $\frac{3}{8}$ -16 x 1 Flathead Stainless Steel (P/N: 2772)
- Secure the Base Plate to a mounting surface:
 - (4) Bolt $\frac{3}{8}$ -16 x 1- $\frac{1}{2}$ Inch, Stainless Steel (P/N: 901594)
 - (4) Flat Washer, $\frac{3}{8}$ Inch, Stainless Steel (P/N: 2054)
 - (4) Lock Washer, $\frac{3}{8}$ Inch, Stainless Steel (P/N: 0801)
 - (4) Nut $\frac{3}{8}$ -16 Inch, Hex, Heavy-Duty, Stainless Steel (P/N: 901593)

- Protect the mast from over-pressurization:
 - (1) Safety Valve:
 - For Hardware Bag 913963: ¼ Inch NPT, 35 PSI (P/N: 913961)
 - For Hardware Bag 902853: ¼ Inch NPT, 55 PSI (P/N: 913962)
- Note: Do not operate mast without Safety Valve properly installed
- Drain water and connect to the Air Supply Line:
 - (2) Close Nipple ¼ Inch Brass (P/N: 900508)
 - (1) Brass Cross (P/N: 900516)
 - (1) Drain Cock #64-T (P/N: 900382)
 - For Hardware Bag 902853:
 - (1) ⅜ x ¼ Inch Reducing Bushing, 125 lb. Red Brass, NPT (P/N: 900522) (Used for Heavy-Duty Masts)
 - (1) Threaded Hex Bushing ¼-½ Inch NPT Brass (P/N: 912293) (Used for Super-Heavy-Duty Masts)

These components ship in the Parts Bag (P/N: 17337) (not shown).

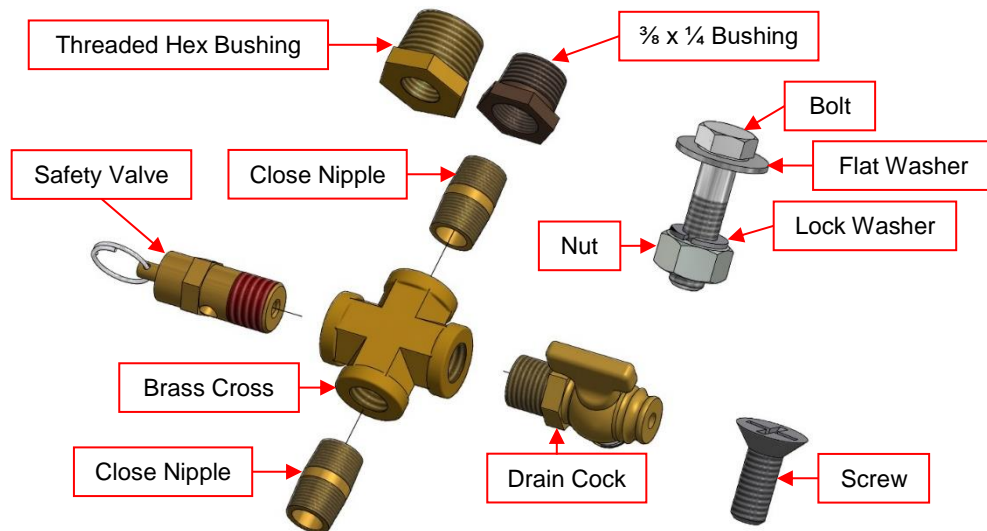

Figure 1-2 Contents of Hardware Bag

1.5.1.2 Drain Kit (P/N: 902982)

The Drain Kit provides a means to route draining water away from the mast by attaching one end of the Drain Kit to the Drain Hole and the other end outside the mounting structure area. Water that has accumulated in the mast should be periodically drained, particularly after the mast has been exposed to rain, in order to prevent damage.

The Drain Kit (Figure 1-3) includes:

- (1) Washer $\frac{3}{8}$ Inch, ID x $\frac{3}{4}$, OD x $\frac{1}{16}$ Thick (P/N: 900555)
- (1) Lock Nut $\frac{1}{8}$ Inch Brass (P/N: 900556)
- (1) $\frac{1}{4}$ Inch Hose Adaptor (P/N: 900564)
- (1) $\frac{1}{4}$ Inch Bulkhead Fitting (P/N: 900565)
- 8 Feet (2.4 m), $\frac{1}{4}$ Inch (6.35 mm) ID, Clear Polyethylene Tube (P/N: 900566)
- (1) Service Sheet 414 (P/N: 4306601) (Not shown)
- (1) Polyethylene Bag 11 x 18, 2 MILS (P/N: 4306301) (Not shown)

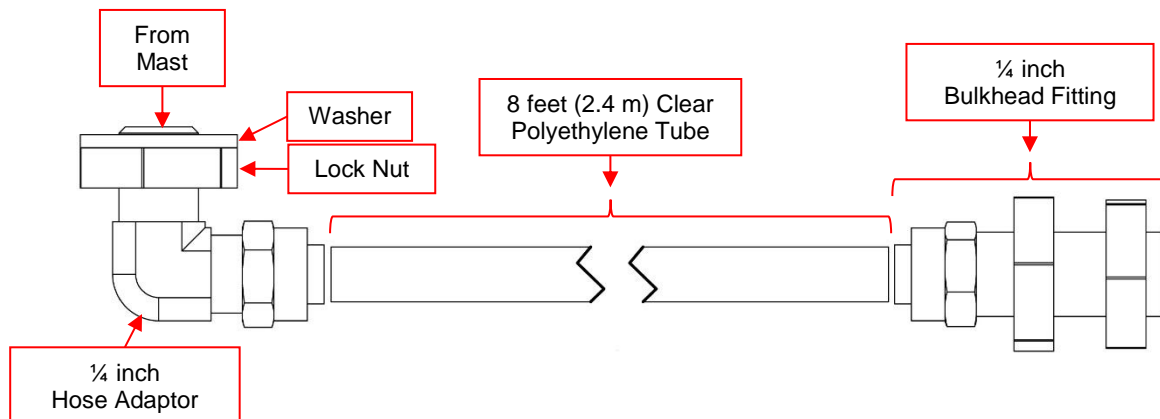

Figure 1-3 Drain Kit (P/N: 902982)

1.5.1.3 Magnetic Warning Kit

The Magnetic Warning Kit is a system designed to warn against moving a vehicle while the mast is partially or fully extended. The operator should always visually confirm that the mast is entirely retracted before moving the vehicle.

The Magnetic Warning Kit is packaged in a brown cardboard box, and in general includes the:

- Clamp which is a thin strip of coiled metal used to brace the switch assembly against the Base Tube
- Magnet which is cylindrical and covered with a wax-like coating
- Switch Assembly which is attached to a small, rectangular casing
- Labels which are gray
- Flasher which has a cylindrical metal casing and is packaged in a rectangular box
- Two red plastic lights

Table 1-11 lists the standard Magnetic Warning Kits for each mast model.

Table 1-11 Magnetic Warning Kits

Magnetic Warning Kit	Mast Model(s)	Figure
P/N: 904314	10-38, 7-42, 8.5-48, 12-48, 9-50, 8.5-52, 9.5-56, 9-58, 10-60, 10.3-60, and 10.8-76	Figure 1-4
P/N: 903523	5-20	Figure 1-5
P/N: 903524	8-30	Figure 1-5
P/N: 903525	6-25 and 7-30	Figure 1-5
P/N: 903598	6-27 and 7-34	Figure 1-5

Note: Mast Models 14.5-80, 15.7-100, 17-100, and 20-134 ship standard without a Magnetic Warning Kit.



#	Description	Quantity
1	Clamp	1
2	Magnet Assembly	1
3	Switch Assembly	1
4	Notice Label	1
5	Warning Label	1
6	Flasher	1
7	Light	2
8	Relay	1
9	Carton (Not Shown)	1

Figure 1-4 Magnetic Warning Kit



#	Description	Quantity
1	Notice Label	1
2	Magnet Assembly	1
3	Switch	1
4	Switch Bracket	1
5	Flasher	1
6	Light	2
7	Clamp	1
8	Nut	2
9	Lock Washer	2
10	Warning Label	1
11	Carton (Not Shown)	1

Figure 1-5 Magnetic Warning Kit

1.5.1.4 Mast Top Cover (P/N: 902989)

The Mast Top Cover comes standard with locking masts. The Mast Top Cover may be ordered separately for non-locking masts.

The Mast Top Cover is:

- A large bag with draw strings
- Pulled over the collars of a fully retracted mast to help protect the locking mechanism and interior of the mast from water, dust, debris, and other foreign material when the mast is not in use

1.5.1.5 Identification Plate

Information pertaining to the mast can be found on the Identification Plate(s) secured to the Base Tube Collar. Standard-Duty masts have two Identification Plates (P/N: 902852 and P/N: 914098) (Figure 1-6 and Figure 1-7). Heavy-Duty and Super-Heavy-Duty masts have one Identification Plate (P/N: 902851) (Figure 1-8).

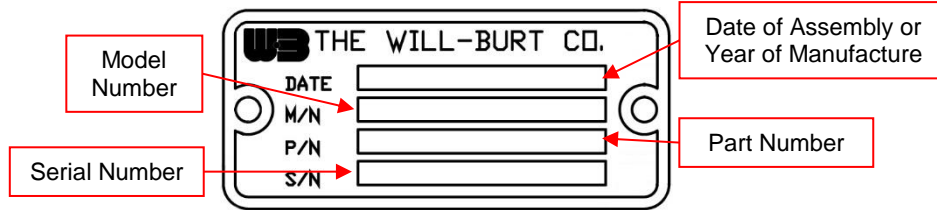

Figure 1-6 Identification Plate (P/N: 902852)

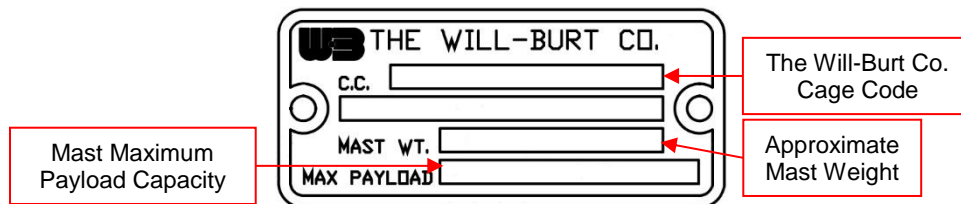

Figure 1-7 Identification Plate (P/N: 914098)

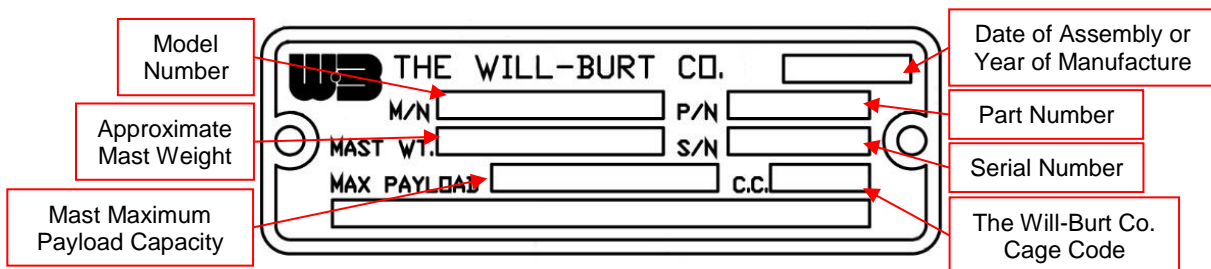

Figure 1-8 Identification Plate (P/N: 902851)

1.5.1.6 Label Kit

The Label Kit is used to identify potential hazards within the Mast System. Some of the labels come installed on the Mast System. Additional labels are provided with the operator's manual (this document). These labels should be applied where the operator will have a clear view of them while operating the mast.

1.5.2 Pneumatic System Options (Sold Separately)

The Pneumatic System refers to a means of safely controlling the pressurization and depressurization of the mast. Components in the Hardware Bag (Section 1.5.1.1) are provided to connect the Air Supply to the mast through an Air Inlet Port. The Air Inlet Port configuration will vary based on the Mast System configuration.

In general, Air Inlet Ports for Standard-Duty and Heavy-Duty masts are as follows (Figure 1-9):

- (1) Side Air Inlet Port
- (1) Bottom Air Inlet Port

In general, Air Inlet Ports for Super-Heavy-Duty masts are as follows (Figure 1-9):

- (1) Front Air Inlet Port
- (1) Rear Air Inlet Port

Some Mast System configurations only have one Air Inlet Port.

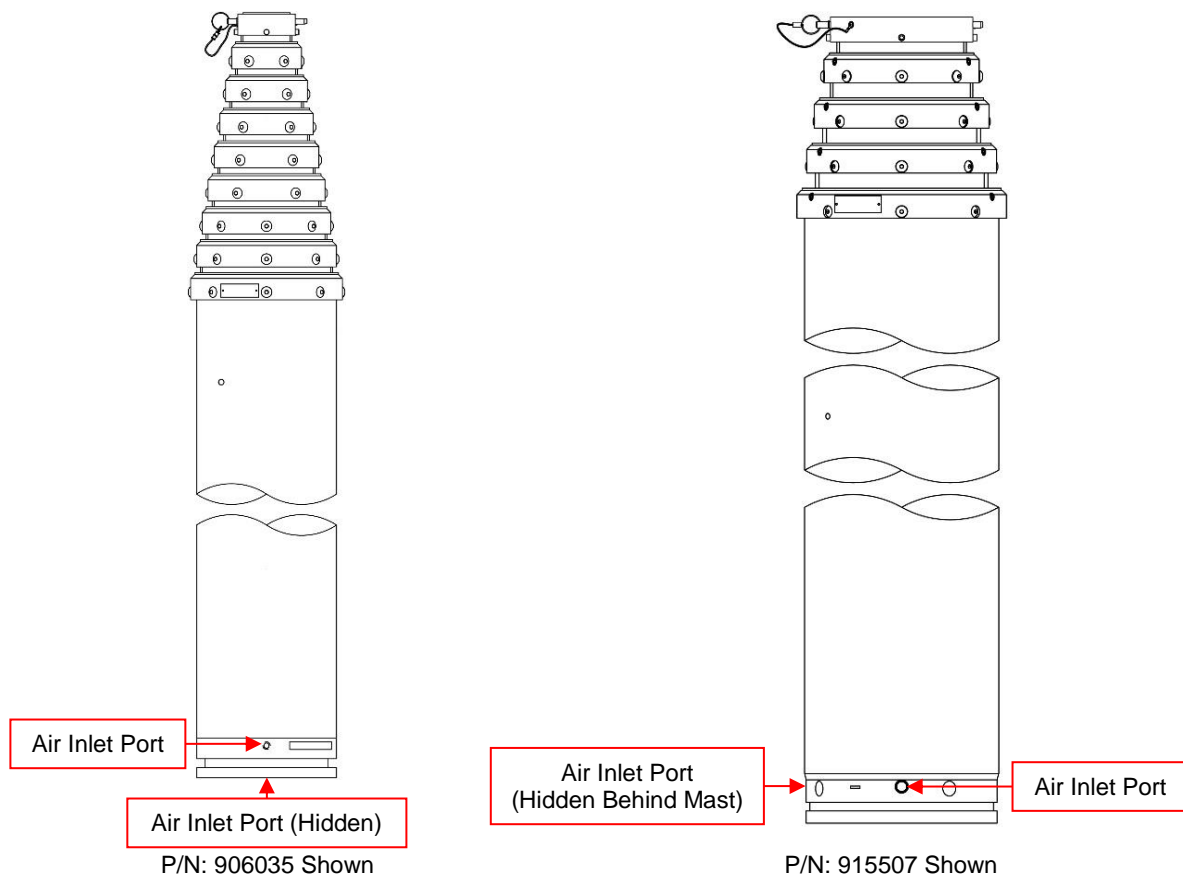

Figure 1-9 Air Inlet Ports (Images Not to Scale)

If desired, Swivel Fittings (P/N: 900481 and P/N: 900483) are available for use with the Bottom Air Inlet Port.

Possible options for the Pneumatic System include:

- Air Compressors
- Filter Regulator Lubricator (P/N: 900484)
- Filter Lubricator (P/N: 900634)
- Solenoid Air Valve Kits
- Hand Pump (P/N: 5050101)

1.5.2.1 Air Compressors

Will-Burt offers a variety of low-maintenance oil-less Air Compressor systems including those listed in Table 1-12.

Table 1-12 Air Compressor Specifications

Functional Characteristic	Specification
12 VDC Compressor (P/N: 5058501)*	
System Weight	29.8 lb. (13.5 kg)
Dimensions (W x H x D)	8 x 11.6 x 11.7 inches (203 x 295 x 298 mm)
Operating Temperature Range	-4 to 122°F (-20 to 50°C)
Air Flow	6.1 CFM (173 LPM)
Current Draw at 2.4 Bar	55 Amps
Check Valve Cut Out	32 ± 2 psi
24 VDC Compressor (P/N: 5058502)*	
System Weight	29.8 lb. (13.5 kg)
Dimensions (W x H x D)	8 x 11.6 x 11.7 inches (203 x 295 x 298 mm)
Operating Temperature Range	-4 to 122°F (-20 to 50°C)
Air Flow	6.7 CFM (191 LPM)
Current Draw at 2.4 Bar	30 Amps
Check Valve Cut Out	32 ± 2 psi
230 VAC 50Hz/60Hz Compressor (P/N: 5255801)*	
System Weight	36.4 lb. (16.5 kg)
Dimensions (W x H x D)	8 x 11.6 x 11.9 inches (203 x 295 x 302 mm)
Operating Temperature Range	-4 to 122°F (-20 to 50°C)
Air Flow	6.5 CFM (185 LPM)
Current Draw at 2.4 Bar	5.1 Amps
Check Valve Cut Out	32 ± 2 psi

Continued

Table 1-13 Air Compressor Specifications Continued

Functional Characteristic	Specification
110 VAC 50Hz/60Hz Compressor (P/N: 5255802)*	
System Weight	25.4 lb. (11.5 kg)
Dimensions (W x H x D)	8 x 11.6 x 11.9 inches (203 x 295 x 302 mm)
Operating Temperature Range	-4 to 122°F (-20 to 50°C)
Air Flow	6.5 CFM (185 LPM)
Current Draw at 2.4 Bar	10 Amps
Check Valve Cut Out	32 ± 2 psi
110 VAC 60Hz Compressor (P/N: 902404)**	
System Weight	45 lb. (20.4 kg)
Dimensions (W x H x D)	15 x 8.91 x 11.61 inches (381 x 227 x 295 mm)
Operating Temperature Range	50° to 104°F (10° to 40°C)
Air Flow	4.4 CFM (125 LPM)
Current Draw at 2.4 Bar	10.6 Amp
Check Valve Cut Out	32 ± 2 psi
220 VAC 60Hz Compressor (P/N: 912361)**	
System Weight	45 lb. (20.4 kg)
Dimensions (W x H x D)	15 x 8.91 x 11.61 (381 x 227 x 295 mm)
Operating Temperature Range	50° to 104°F (10° to 40°C)
Air Flow	3.6 CFM (101 LPM)
Current Draw at 2.4 Bar	5.3 Amp
Check Valve Cut Out	32 ± 2 psi
<p>* Has an optional a Hand-Held Remote Control with a 16 feet (5 m) cable (P/N: 5346601)</p> <p>** Includes in-line manual Air Control Valve</p> <p>Note: Specifications provided are for reference only and may be subject to change without notice</p>	

1.5.2.2 Filter Regulator Lubricator (P/N: 900484)

A Filter Regulator Lubricator (Figure 1-10) is available for use with the following Air Compressors:

- 110 VAC Air Compressor (P/N: 902404)
- 220 VAC Air Compressor (P/N: 912361)



Figure 1-10 Filter Regulator Lubricator (P/N: 900484)

1.5.2.3 Filter Lubricator (P/N: 900634)

A Filter Lubricator (Figure 1-11) is available for use with the following Air Compressors:

- 110 VAC Air Compressor (P/N: 902404)
- 220 VAC Air Compressor (P/N: 912361)

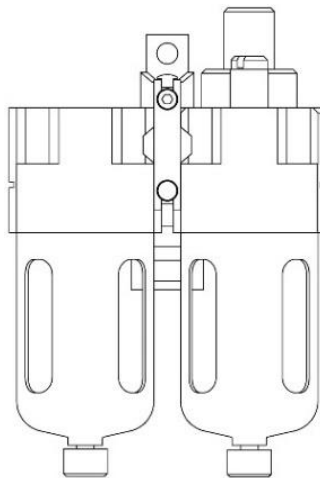

Figure 1-11 Filter Lubricator (P/N: 900634)

1.5.2.4 Solenoid Air Valve Kits

Will-Burt offers the following Solenoid Air Valve Kits (Figure 1-12):

- 110 VAC Solenoid Air Valve Kit (P/N: 911145) for use with Air Compressor P/N: 902404
- 220 VAC Solenoid Air Valve Kit (P/N: 5079301) for use with Air Compressor P/N: 912361

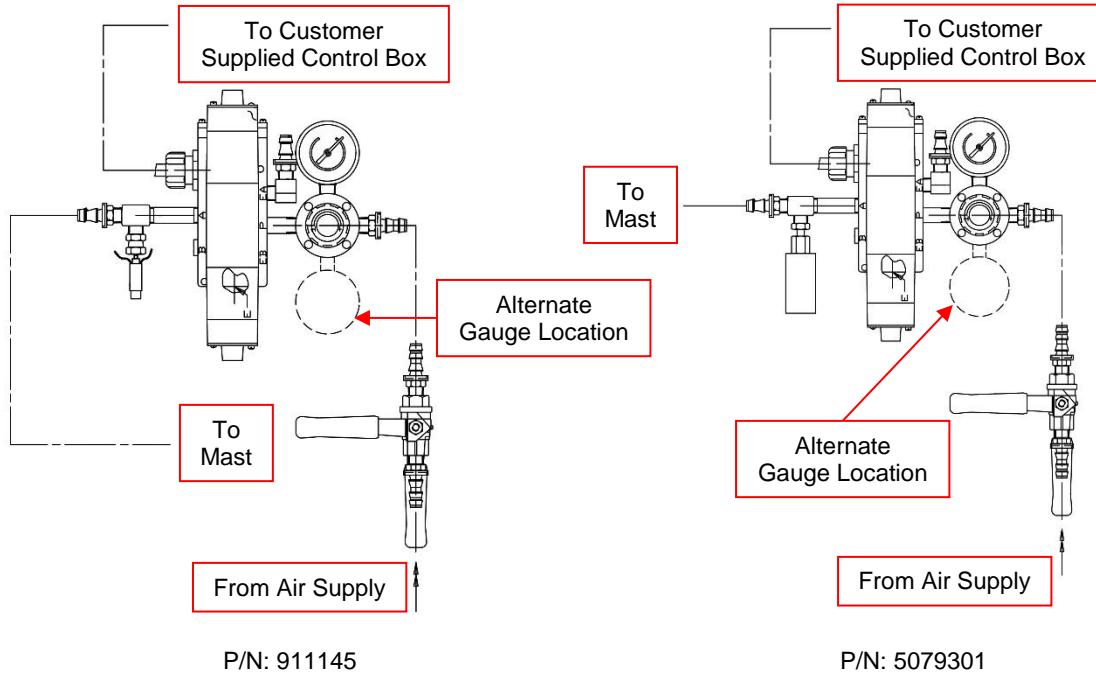

Figure 1-12 Solenoid Air Valve Kits

A Hand-Held Remote Controller (HHRC) (P/N: 912247) (Figure 1-13) is available with these Solenoid Air Valve Kits.



Figure 1-13 Hand-Held Remote Controller (P/N: 912247)

1.5.2.5 Hand Pump (P/N: 5050101)

The Hand Pump (Figure 1-14) is used to deploy the mast where electric or pneumatic power is not available.

Features:

- Constructed of steel and aluminum
- Pumps air in both downward and upward stroke
- Operates between -4°F and 140°F (-20°C and 60°C)

The Hand Pump includes:

- (1) Hand Pump (P/N: 5050001)
- 6 feet (1.8 m) of Air Hose (P/N: 108768)
- (2) Push Connector Fittings (P/N: 4024001)



Figure 1-14 Hand Pump (P/N: 5050001)

1.5.3 Mounting Hardware Options (Sold Separately)

Mounting hardware is used to secure the mast in place.

Possible options for the mounting hardware include:

- Base Plate Options
 - Non-Rotatable Base Plates
 - Rotatable Hardware Kits
 - Field Mount and Dog Dish Base Plates
- Support Bracket Options
 - Internal (Roof) Mounting Kit
 - External Support Bracket
- Shelf Bracket

1.5.3.1 Base Plate Options

The Base Plate is used to stabilize the mast and to provide a means of securing the mast to a mounting surface.

Base Plate options include:

- Non-Rotatable Base Plates
- Rotatable Hardware Kits
- Field Mount and Dog Dish Base Plates

Non-Rotatable Base Plates

The Non-Rotatable Base Plate (Figure 1-15) is a square plate with countersunk holes that match threaded holes on the Base Tube. Non-Rotatable Base Plates for Standard-Duty and Heavy-Duty masts typically have a hole in the center of the Base Plate to allow for the option of routing air to the bottom of the Base Tube. Non-Rotatable Base Plates for Super-Heavy-Duty masts typically do not have the center hole.

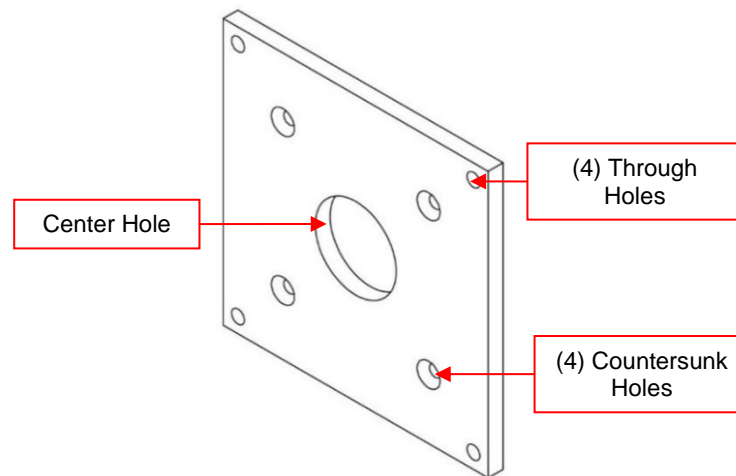

Figure 1-15 Non-Rotatable Base Plate (P/N: 902044 Shown)

Screws from the Hardware Bag (Section 1.5.1.1) can be used to attach the Non-Rotating Base Plate to the base of the mast. Bolts, nuts, and washers from the Hardware Bag are sized for the through holes in the corners of the Base Plate so the mast can be secured to a mounting surface.

For more information on Non-Rotatable Base Plate options, see www.willburt.com.

Rotatable Hardware Kits

In addition to stabilizing and securing the mast to a mounting surface, the Rotatable Base Plate (Figure 1-16) and Turning Handles (Figure 1-17) enable the mast to be rotated. The exact configuration of the Rotatable Base Plate may vary.

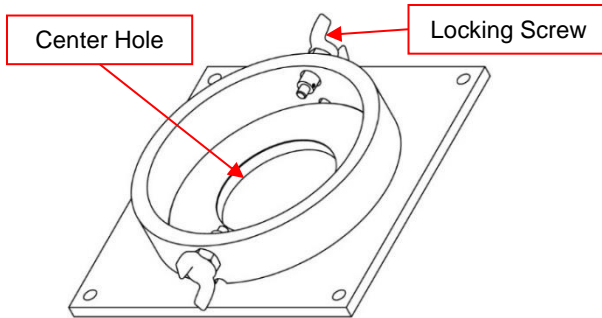

Figure 1-16 Rotatable Base Plate Assembly
(P/N: 5074601 Shown)



Figure 1-17 Turning Handles Assembly
(P/N: 908174 Shown)

In general, the Rotatable Hardware Kit includes:

- A Rotatable Base Plate Assembly
- A Turning Handles Assembly
- An Instruction Sheet

The Turning Handles Assembly:

- Wraps around the Base Tube and is secured with hardware included in the kit
- Aids the operator in rotating the mast into position

A hole in the center of the Rotatable Base Plate (Figure 1-16) allows the option of routing air to the bottom of the Base Tube.

Note: The Rotatable Base Plate Assembly for a Super-Heavy-Duty mast does not use Turning Handles. Instead, rotating Super-Heavy-Duty masts have four holes spaced 90° apart in the Tube Head where a customer-supplied rod can be inserted to provide leverage to turn the mast.

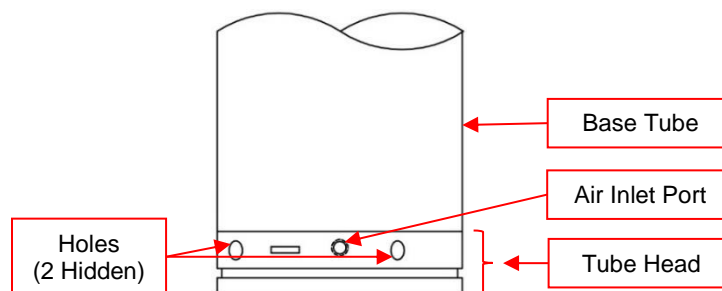

Figure 1-18 Bottom of Rotatable Super-Heavy-Duty Mast (P/N: 909426 Shown)

For more information on Rotatable Hardware Kit options, see www.willburt.com.

Field Mount and Dog Dish Base Plates

In addition to the standard non-rotating and rotating Base Plates, The Will-Burt Company also offers Field Mount Base Plates (Figure 1-19) and Dog Dish Base Plates (Figure 1-20).

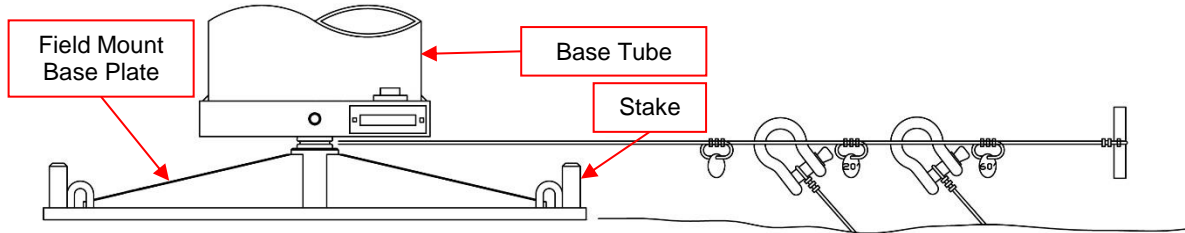

Figure 1-19 Field Mount Base Plate (Base Plate P/N: 903403 Shown)

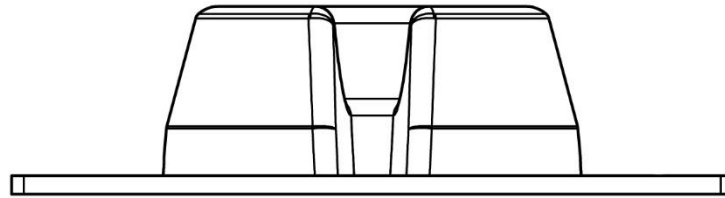

Figure 1-20 Dog Dish Base Plate (P/N: 4201401 Shown)

These Base Plates are typically:

- Used for field applications
- Guyed at the Base Tube, eliminating the need for a Support Bracket (Section 1.5.3.2)
- Used with taller masts

For more information on the installation and operation of these Base Plate options, contact The Will-Burt Company.

1.5.3.2 Support Bracket Options

The Support Bracket is used to secure the mast to a support structure.

The Support Bracket can be an:

- Internal (Roof) Mounting Kit
- External Support Bracket

Internal (Roof) Mounting Kit

The Internal Mounting Kit (Figure 1-21) contains the hardware used to position and support an internally mounted mast. Internal Mounting Kits are available for both non-rotatable and rotatable masts. Customer-supplied $\frac{1}{4}$ inch (M6) bolts, lock washers, and hex nuts shall be used as fasteners. Bolt length depends on the specific application and is to be determined by the customer.

Internal Mounting Kits for Standard-Duty and Heavy-Duty masts include:

- (1) Weather Bonnet
- (2) Gaskets
- (1) Bearing Strip
- (1) Ceiling Plate
- (1) Roof Flange
- (1) O-Ring

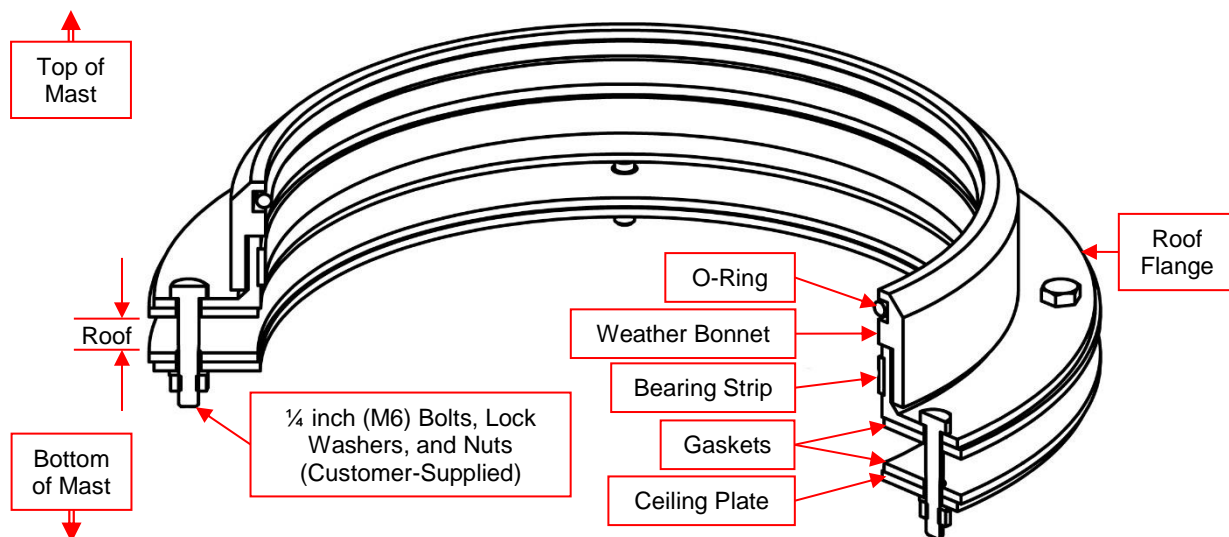

Figure 1-21 Internal Mounting Kit for Standard-Duty and Heavy-Duty Masts (P/N: 905733 Shown)

Internal Mounting Kits for non-rotating Super-Heavy-Duty masts include:

- (1) Roof Ring
- (2) Gaskets
- (1) Bearing Strip
- (1) Ceiling Plate
- (1) Retaining Ring
- (1) O-Ring

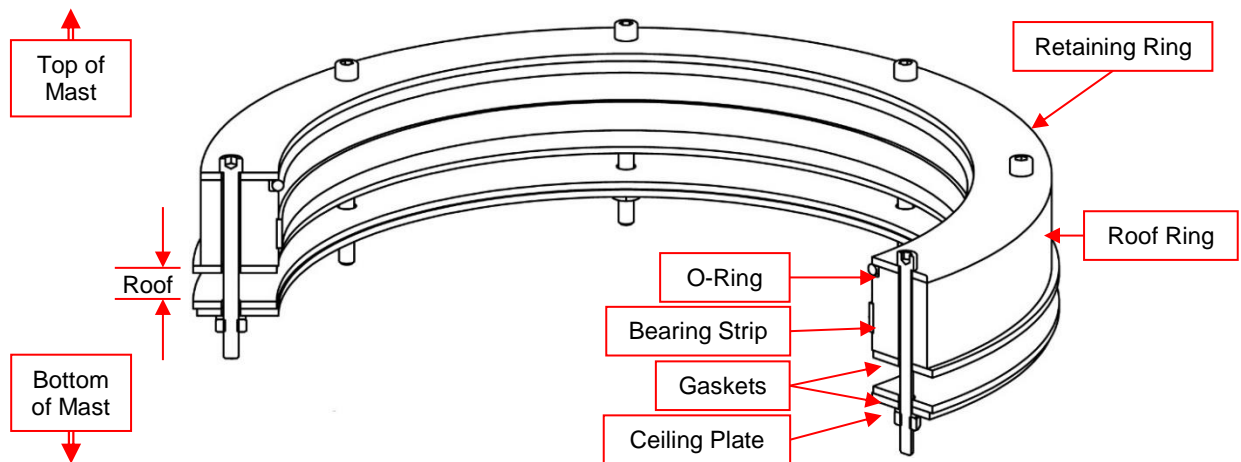

Figure 1-22 Internal Mounting Kit for Non-Rotating Super-Heavy-Duty Masts (P/N: 910784 Shown)

Internal Mounting Kits for rotating Super-Heavy-Duty masts have the same components as the Internal Mounting Kits for non-rotating masts, but remove the O-Ring and add the Flashing Kit.

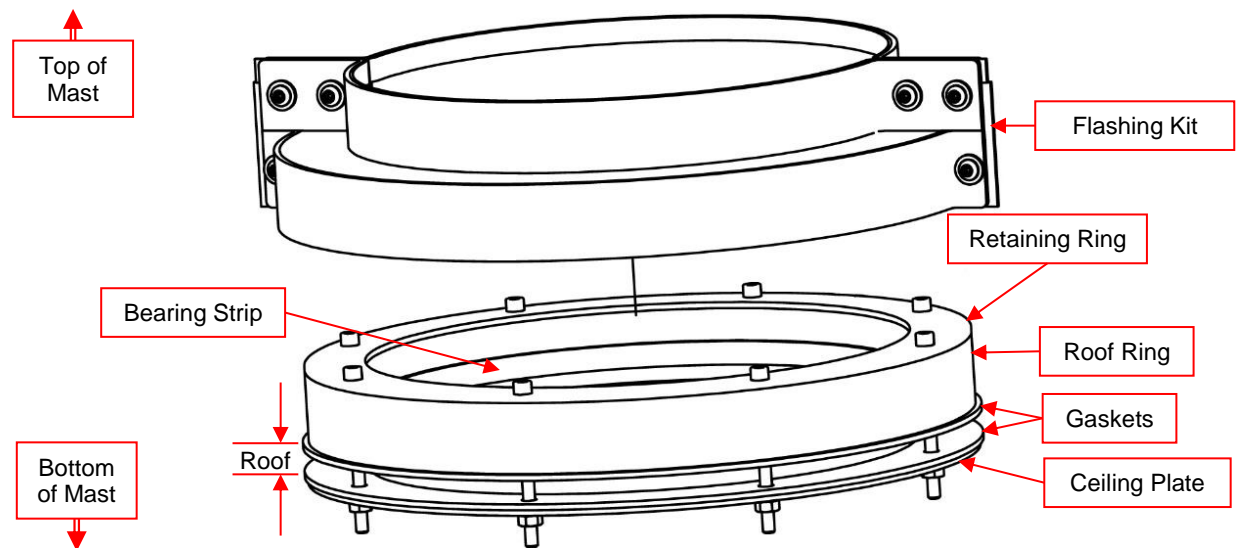

Figure 1-23 Internal Mounting Kit for Rotating Super-Heavy-Duty Masts (P/N: 4915901 Shown)

For more information on Internal Mounting Kits options, see www.willburt.com.

External Support Bracket

The External Support Bracket Assembly (Figure 1-24) is used to position and support Standard-Duty and Heavy-Duty masts.

The External Support Bracket is constructed from:

- (1) Stand-Off which positions the Support Brackets away from the support structure
- (2) Support Brackets which close around the Base Tube and are bolted together to hold the mast against the mounting structure
- Bearing Strips attached inside the Support Brackets which protects the Base Tube from being scraped by the Support Brackets and allows the mast to be rotated
- Hardware to secure the assembly together

Note: External Support Brackets for masts 9 inch (229 mm) Base Tube diameters have a brace across the Stand-Off.

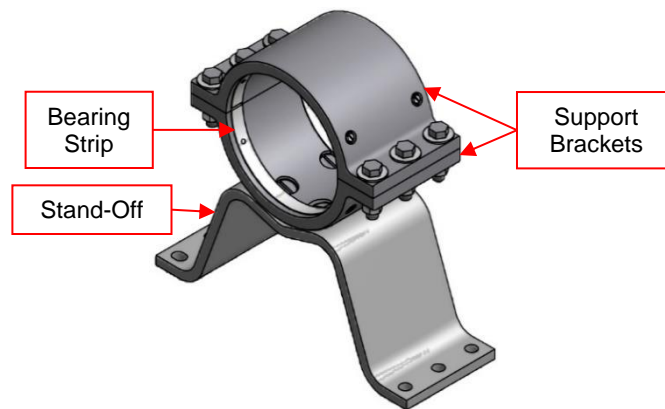

Figure 1-24 External Support Bracket (P/N: 4443601 Shown)

External Support Brackets are also available for Super-Heavy-Duty masts (Figure 1-25).

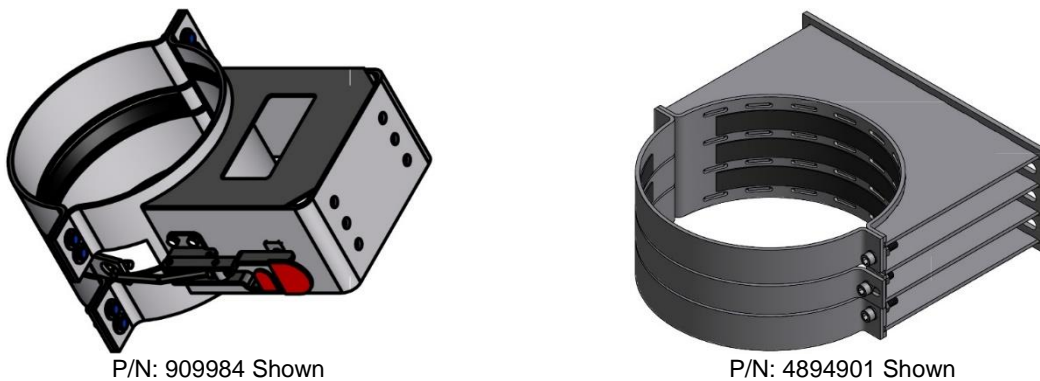

Figure 1-25 Super-Heavy-Duty External Support Brackets

For more information on External Support Bracket options, see www.willburt.com.

1.5.3.3 Shelf Bracket

The Shelf Bracket can be bolted into a support structure and used to position and support an externally mounted mast. Shelf Brackets are available for use with both Non-Rotatable Base Plates and Rotatable Base Plates and for various sized masts. When using the Shelf Bracket, the Shelf Bracket becomes the mounting surface for the Base Plate.

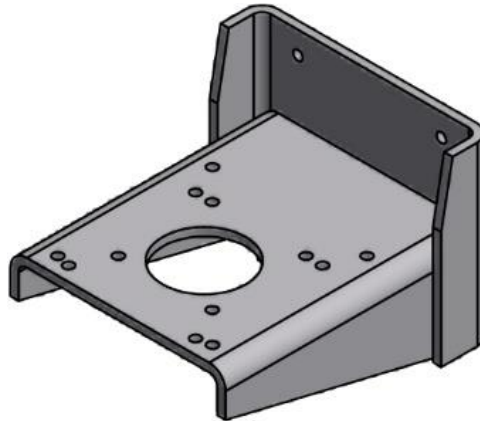

Figure 1-26 Shelf Bracket (P/N: 4434101 Shown)

For more information on the Shelf Bracket options, see www.willburt.com.

1.5.4 Payload Platforms and Stub Adaptors (Sold Separately)

Payload Platforms (Figure 1-27) and Stub Adaptors (Figure 1-28) attach to the top of the mast and are used to secure and support the payload during operation. Payload Platforms and Stub Adaptors come in varying sizes and configurations. It is possible to guy directly to some Payload Platforms and Stub Adaptors.

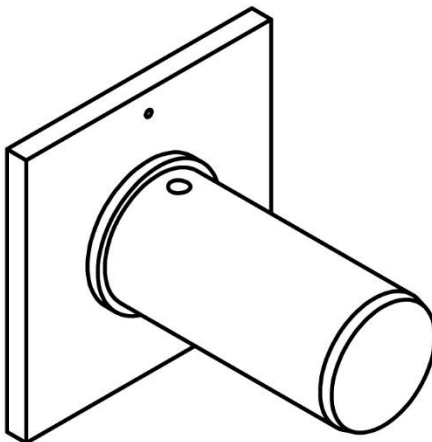

Figure 1-27 Payload Platform (P/N: 915343 Shown)

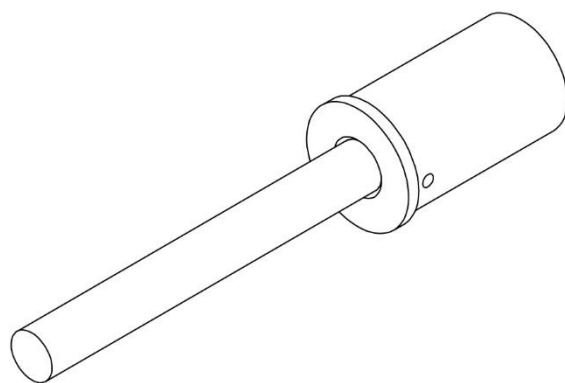

Figure 1-28 Stub Adaptor (P/N: 910353 Shown)

Payload Platforms are available both with through holes to allow for quick installation of customer payloads, and without through holes to allow the customer to drill through holes to match payload-specific mounting hole patterns.

1.5.5 Guy Line Kit Options (Sold Separately)

Guy Line Kits are used to further stabilize the mast by resisting environmental conditions that may cause tip-over and horizontal payload moment. Use of a Guy Line Kit is required for the operation of some of the taller model masts (Section 1.4). Use of a Guy Line Kit may be required for customer-specific payloads or to achieve specific survival wind speeds. Consult Will-Burt engineering.

The exact configuration of the Guy Kit will vary based on the mast configuration and environmental requirements. Some Guy Kits require a Payload Platform or Stub Adaptor that can be directly guyed. Components may include:

- Guy Line Assemblies
- Ground Anchors
- A Ground Anchor location drawing

For additional information on Guy Kits, see www.willburt.com.

1.5.6 Additional Accessory Options

Will-Burt provides a number of additional accessory options (Table 1-13) for the Mast System.

Table 1-13 Additional Accessory Options

Accessory	Used To:
Pneumatic Mast Antifreeze Kit (P/N: 4725801)	Weatherize pneumatic masts in extremely harsh environmental conditions.
D-TEC [®] Safety System	Provide overhead power line detection and above the mast illumination.
PositionIt [™]	Remotely pan and tilt a payload.
Trip Line Kits	Allow a mast to be deployed from the bottom up. Useful when guying tall masts.
Cable Guide Ring Kits	Manage cables, Guy Lines, and Trip Lines. Typically used on locking masts.
Yoke Snagger	Enable access to yokes beyond arms reach.
Nycoil [®] Cable Conduit	Manage payload cables. Typically used with non-locking masts.
Nycoil [®] Basket	Manage Nycoil [®] Cable Conduit
Intermediate Tube Clamps	Assist in attaching a payload on an Intermediate Tube.
External Wipers	Protect against sand and dust.

For more information on these and other additional accessory options, or customized solutions to customer-specific scenarios, see www.willburt.com.

Section 2 Installation

This section describes the installation of the Mast System and provides general procedures that must be followed to ensure a successful installation. Use care to understand and follow all precautions while installing.

2.1 Pre-Installation Check

Before installing the Mast System, ensure:

- All installers read and understand the entire installation procedure
- Only a properly trained and qualified certified electrician performs electric installations and maintenance
- The mounting structure is level and has sufficient room and strength to mount the Mast System (Section 1.4 and 2.6)
- All purchased components are included (Section 1.5)
- All required equipment is readily available (Section 2.2)
- When installing in a vehicle, that the vehicle is stationary and on a level surface
- That the following precautions are understood and followed:

⚠ WARNING

Mounting Structure Hazard! Before installation, ensure the mounting structure is capable of resisting forces generated from all loading and environmental conditions, including, but not limited to, Mast System size and weight, payload size and weight, sail size, wind speed, Guy Line arrangement, support bracket or roof line location and base plate assembly. Mounting the Mast System into a structure unable to resist the forces generated from the customer-specific loading scenario could result in death or serious injury, and could damage the Mast System.

⚠ CAUTION

Equipment Damage – Qualified Personnel! All persons installing and maintaining this equipment should be suitably qualified and work to local, regional, and national standards and codes of practice.

⚠ CAUTION

Safety Instruction – Roof Access! If mast will be mounted to a vehicle, the operator must provide safe means to access the roof of the vehicle during installation and maintenance.

2.2 Installation Equipment

Table 2-1 lists general equipment recommended for installation. Depending on the Mast System configuration, additional equipment may be required.

Table 2-1 Equipment Recommended for Installation

Recommended Equipment*			
Personal Protective			
	Safety Glasses	Work Gloves	Nitrile or Vinyl Gloves
	Hearing Protection	Hard Hat or Helmet	Safety Shoes
Hand Tools			
	Drill	Hammer	Hex Wrenches
	Level	Measuring Tape	Plumb-Bob
	Rubber Mallet	Saw	Screwdrivers
	Sockets	Torque Wrench	Wrenches
	String or Thin Wire	Washers or Spacers (For shimming)	
	16 AWG Stranded Wire (For the Magnetic Warning Kit)		
	Appropriate Hardware (Section 2.3)		
Equipment			
	Compressed Air Supply	Hoist	Sling / Strap
Expendables			
	Pipe Thread Sealant or PTFE Tape	Rags (Clean and Dry)	Silicone Sealant
	Loctite® 242/243 (Blue) or Equivalent	Soapy Water (When installing the Weather Bonnet)	
* Note:			
<ul style="list-style-type: none"> Depending on the local, regional, and national standards and codes of practice, and the environment, additional personal protective equipment may be necessary. Depending on the Mast System configuration, additional equipment, including but not limited to, rubber washers or grommets (for the pneumatic system), electrical components (e.g. wire, fuses, circuit breakers, etc.), and Air Control Valves, switches, air hose and fittings, may be required. When disposing of any disposables or components, do so according to any applicable local, regional, and national standards and codes of practice. 			

2.3 Installation Hardware

This section describes hardware that may be used during installation as follows:

- Table 2-2 Hardware for Internal Mount Application Installation
- Table 2-3 Hardware for External Mount Application Installation

Table 2-2 Hardware for Internal Mount Application Installation

Hardware*	Supplied By	Notes
Internal Mounting Kit (To the Roof)		
¼ Inch (M6) Bolts	Customer	Internal Mounting Kits for 6.75, 9.0, and 11.25 inch Base Tubes require eight sets of hardware. Internal Mounting Kits for 5.0 inch Base Tubes require six sets of hardware. The bolts should be sized to length to allow for the thickness of the Internal Mounting Kit, lock washer, nut, roof, and any spacers.
¼ Inch (M6) Lock Washers	Customer	
¼ Inch (M6) Nuts	Customer	
Non-Rotatable Base Plate (To the Mast)		
(4) ⅜-16x1 Flathead Screws (P/N: 2772)	Will-Burt	Found in the Hardware Bag
Non-Rotatable and Rotatable Base Plate (To the Mounting Surface)		
(4) ⅜-16x1-½ Inch Bolts (P/N: 901594)	Will-Burt	Found in the Hardware Bag
(4) Flat Washers (P/N: 2054)	Will-Burt	Found in the Hardware Bag
(4) Lock Washers (P/N: 0801)	Will-Burt	Found in the Hardware Bag
(4) Nuts (P/N: 901593)	Will-Burt	Found in the Hardware Bag
Turning Handles (To Mast)		
(2) ¼-20x1.50 Hex HD Bolts (P/N: 2000)	Will-Burt	Ships with Turning Handles
(2) ¼-20 Nyloc Nuts (P/N: 1930)	Will-Burt	Ships with Turning Handles
Flashing Kit (Rotatable Super-Heavy-Duty Masts) (To the Mast)		
(6) ¼-20x0.75 Inch Bolts (P/N: 4542)	Will-Burt	Ships with Flashing Kit
(12) ¼ Flat Washers (P/N: 0800)	Will-Burt	Ships with Flashing Kit
(6) ¼ Nyloc Nuts (P/N: 1930)	Will-Burt	Ships with Flashing Kit
* Unless otherwise indicated, the mounting hardware must include proper means to resist vibration loosening such as thread-locking compound or locking hardware. Torque all hardware as appropriate for its size and grade. Torque values in these instructions assume the use of the Will-Burt provided hardware. Depending on the specific installation application, all hardware may not be used. Additional hardware may be required for additional accessories, or customer-specific applications.		

Table 2-3 Hardware for External Mount Application Installation

Hardware*	Supplied By	Notes
Shelf Bracket (Optional) (To the Support Structure)		
(4) Bolts	Customer	Bolts should be sized to length to allow for the thickness of the Shelf Bracket, support structure, and any spacers and mounting hardware. Shelf Bracket P/N: 4434101 uses 3/8 inch hardware. This Shelf Bracket is used for non-rotating and rotating masts with 5.0 inch Base Tubes and non-rotating masts with 6.75 inch Base Tubes. Shelf Brackets P/N: 4454001, P/N: 4454101, and P/N: 913947 use 1/2 inch hardware. (Part Numbers for clear anodized finish only.)
(4) Flat Washers	Customer	
(4) Lock Washers	Customer	
(4) Nyloc Nuts	Customer	
Non-Rotatable Base Plate (To the Mast)		
(4) 3/8-16x1 Flathead Screws (P/N: 2772)	Will-Burt	Found in the Hardware Bag
External Support Bracket (P/N: 4443601) (To the Support Structure)		
(6) Sets of 3/8 Inch Hardware	Customer	The bolts should be sized to length to allow for the thickness of the External Support Bracket, support structure, any spacers, and all mounting hardware (e.g. flat washers, lock washers, and nuts).
External Support Bracket (P/N: 909984 and P/N: 4894901) (To Support Structure)		
(6) Sets of 1/2 Inch Hardware	Customer	The bolts should be sized to length to allow for the thickness of the External Support Bracket, support structure, any spacers, and all mounting hardware (e.g. flat washers, lock washers, and nuts).
Non-Rotatable and Rotatable Base Plate (To the Mounting Surface)		
(4) 3/8-16x1-1/2 Inch Bolts (P/N: 901594)	Will-Burt	Found in the Hardware Bag
(4) Flat Washers (P/N: 2054)	Will-Burt	Found in the Hardware Bag
(4) Lock Washers (P/N: 0801)	Will-Burt	Found in the Hardware Bag
(4) Nuts (P/N: 901593)	Will-Burt	Found in the Hardware Bag
Turning Handles (To Mast)		
(2) 1/4-20x1.50 Hex HD Bolts (P/N: 2000)	Will-Burt	Ships with Turning Handles
(2) 1/4-20 Nyloc Nuts (P/N: 1930)	Will-Burt	Ships with Turning Handles
* Unless otherwise indicated, the mounting hardware must include proper means to resist vibration loosening such as thread-locking compound or locking hardware. Torque all hardware as appropriate for its size and grade. Torque values in these instructions assume the use of the Will-Burt provided hardware. Depending on the specific installation application, all hardware may not be used. Additional hardware may be required for additional accessories, or customer-specific applications.		

2.4 Lift the Mast System

During installation, it will be necessary to lift the mast. The process described in this manual represents a possible method of lifting the mast. Depending on the environment and equipment available, other methods may work better. Use the best and safest method for your circumstances.

⚠ WARNING

Safety Instruction – Observe Proper Procedures! Use extreme caution while lifting the Mast System and when Mast System is suspended to avoid injury and equipment damage. Be certain the Mast System is properly secured. All operators should be aware of and follow the applicable local, regional, and national standards and codes of practice for slinging and transporting equipment. Never lift Mast System over people. Ensure lifting equipment including, but not limited to, lifting straps and hoist, are capable of handling the forces generated from lifting the system. Observe manufacturer instructions on lifting equipment. Death or serious injury could result if proper procedures are not followed.

⚠ CAUTION

Equipment Damage – Forces! Before unloading the system, be certain the unloading region is capable of resisting forces generated from unloading the system including but not limited to system weight. Ensure the unloading region is level and has sufficient room and strength to hold the system. If the unloading region is incapable of meeting the requirements of the system, damage to the system and/or unloading region could occur.

2.5 Unpack the Mast System

⚠ CAUTION

Lifting Hazard – Manually Lifting! Manually lifting over 55 lb. (25 kg) is prohibited. In the UK, all lifting equipment must be thoroughly examined annually by a competent person according to the Lifting Operations and Lift Equipment Regulations 1998. Equivalent regulations exist in other EU states.

Unpack the system as follows:

1. Carefully open the shipping crate.
2. Inspect for any shipping damage. Notify the carrier if damage is evident.

3. Remove all loose components, the 2 x 4 inch (38 x 89 mm) block at the top end of the mast, and the top half of the wooden mast saddles (Figure 2-1).

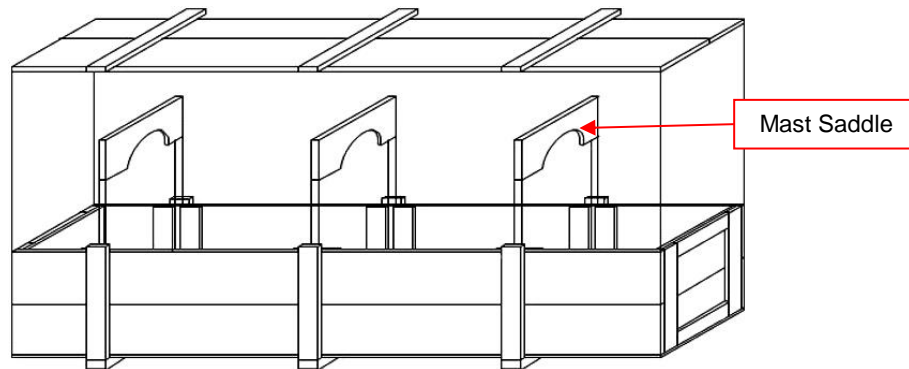

Figure 2-1 Shipping Crate

4. Using the center of gravity (COG) label as a reference, outfit the mast with a sling capable of supporting the mast weight (Figure 2-2). The sling must support the mast from at least two points. Attach the sling so that horizontal balance and control can be maintained while positioning the mast. Hoist and slowly lift the mast until just free of the mast saddles. Lower the mast and adjust the sling as necessary to balance the mast. Hoist the mast free from the crate and carefully move the mast into the desired position.

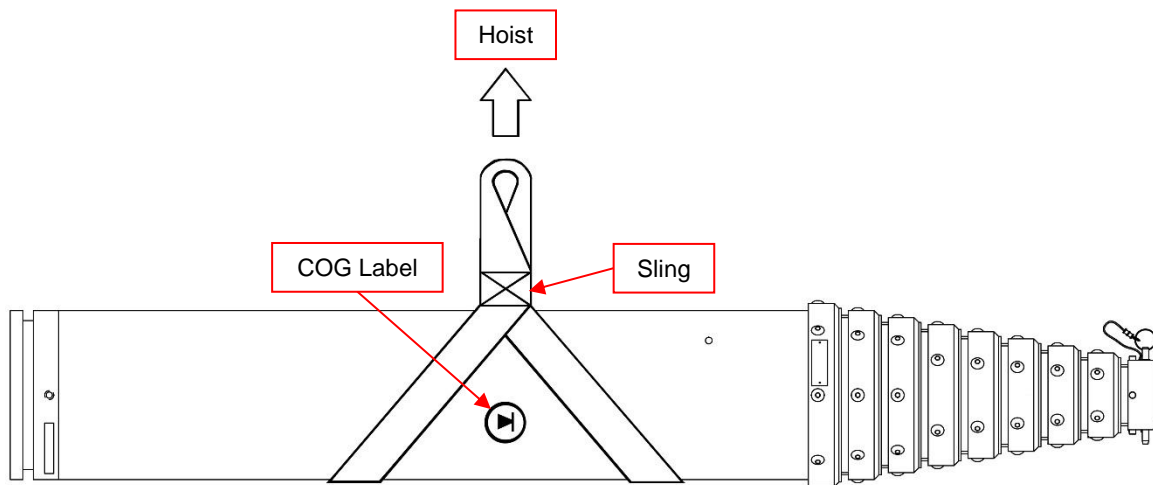

Figure 2-2 Hoist the Mast

The Will-Burt Company recommends keeping the shipping crate for transporting the mast, for example if shipping the mast back to the factory for refurbishment.

2.6 Installation Specifications

This section describes installation specifications as follows:

- Mast Installation Specifications (Section 2.6.1)
- Non-Rotating Base Plate Installation Specifications (Section 2.6.2)
- Rotating Base Plate Installation Specifications (Section 2.6.3)
- Turning Handle Assembly Installation Specifications (Section 2.6.4)
- Internal Mounting Kit Installation Specifications (Section 2.6.5)
- Support Bracket Assembly Installation Specifications (Section 2.6.6)
- Shelf Bracket Assembly Installation Specifications (Section 2.6.7)

Dimensions and specifications provided are for reference only, and are not intended for vehicle design purposes. Depending on the Mast System and components being used, the exact design of components may vary. Masts with other heights, capacities, and finishes are available. For more information on additional mast sizes, capabilities, and finishes, see www.willburt.com.

2.6.1 Mast Installation Specifications

Table 2-4 Mast Installation Specifications

P/N*	MODEL	A		B		C	
		inch	mm	inch	mm	inch	mm
Standard-Duty							
906021	5-20	64	1626	51.8	1316	41.8	1062
906023	6-27	72	1829	58.4	1483	48.3	1227
906025	7-34	84	2134	70.4	1788	60.3	1532
906027	8-30	96	2438	88.4	2245	71.5	1819
Heavy-Duty Non-Locking							
906029	6-25	70	1778	59.8	1519	47.6	1209
906033	7-30	79	2007	69.1	1755	55.3	1405
906035	7-42	85	2159	69.1	1755	49.6	1260
906215	8.5-48	103	2616	89.0	2261	73.6	1869
906037	8.5-52	99	2515	83.5	2121	64.0	1626
906039	9.5-56	113	2870	99.0	2515	79.5	2019
906041	9-58	107	2718	91.5	2324	72.0	1829
Heavy-Duty Locking							
906043	7-30	84	2134	68.3	1735	55.3	1405
906045	7-42	92	2337	68.4	1737	49.6	1260
906051	10-60	122	3099	101.1	2568	82.4	2093
906053	14.5-80	171	4343	152.5	3874	129.7	3294
906055	17-100	208	5283	186.6	4740	163.8	4161
906057	20-134	245	6223	221.0	5613	189.9	4823
Super-Heavy-Duty Non-Locking							
915507	10-38	119	3023	110.1	2797	86.3	2192
710904800	12-48	143	3658	133.9	3401	110.2	2799
Super-Heavy-Duty Locking							
909959	9-50	110	2794	89.6	2276	66.5	1689
909426	10.3-60	125	3175	104.6	2657	81.5	2070
910916	10.8-76	131	3327	104.6	2657	81.5	2070
912970	15.7-100	187	4750	166.6	4232	143.5	3645

* Part Numbers for clear anodized finish. Additional finishes are available.

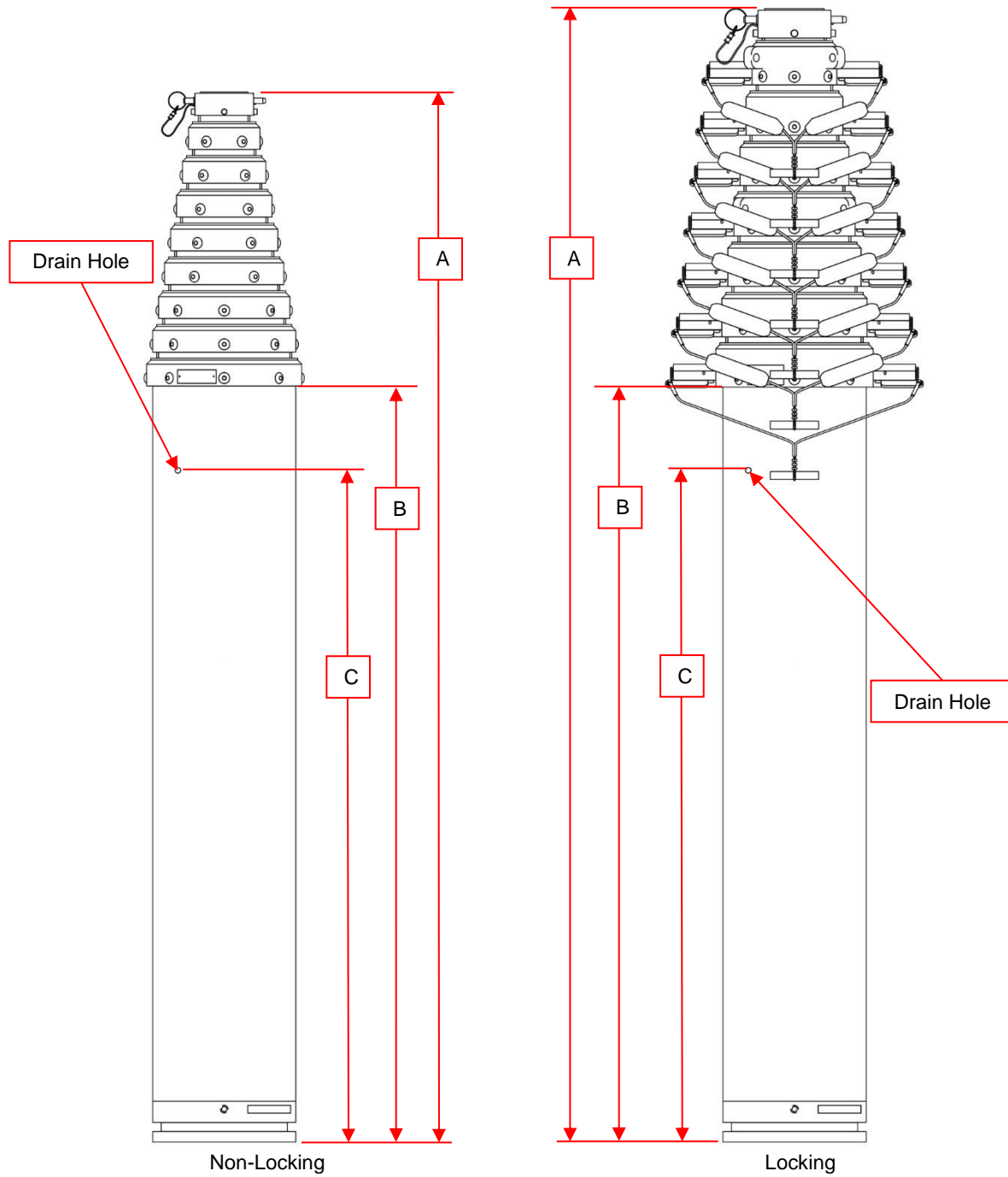

Figure 2-3 Mast Installation Specifications (Not to Scale)

2.6.2 Non-Rotating Base Plate Installation Specifications

Table 2-5 Non-Rotating Base Plate Installation Specifications

P/N*	Base Tube	A		B		C		D		Ø BCD	
		inch	mm	inch	mm	inch	mm	inch	mm	inch	mm
902491	5	5	127	4.25	108	7/16	11	0.5	12.7	4.0	101.6
902363	6 ¾	6 ¾	171	5 ¾	146	7/16	11	0.5	12.7	4.75	120.65
902044	9	9	229	8	203	7/16	11	0.5	12.7	7.0	177.8
909427	11 ¼	12	305	11	279	9/16	14	0.5	12.7	9.5	241.3

* Part Numbers for clear anodized finish. Additional finishes are available.

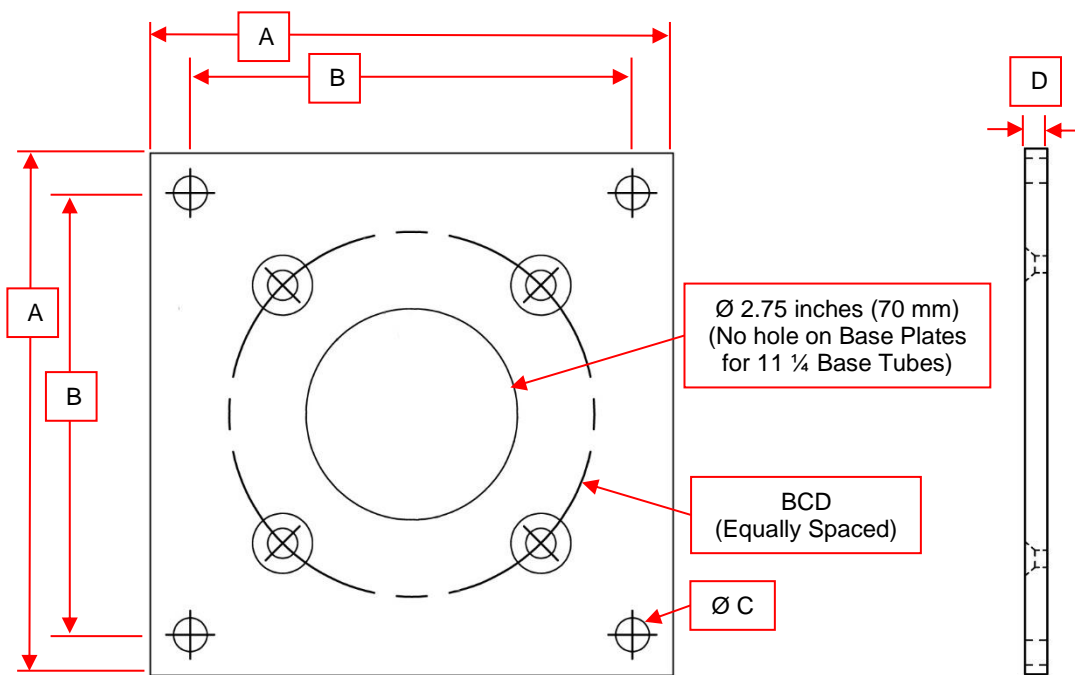

Figure 2-4 Non-Rotating Base Plate Installation Specifications (P/N: 902491 Shown)

2.6.3 Rotating Base Plate Installation Specifications

Table 2-6 Rotating Base Plate Installation Specifications

P/N*	Base Tube	A		B		C		D		Est. Weight	
		inch	mm	inch	mm	inch	mm	inch	mm	lb.	kg
902492	5	8	203	7	178	0.38	9.7	0.4	10	8.6	3.9
902364	6 ¾	9 ¾	248	8.7	222	0.38	9.7	0.4	10	12.4	5.6
902344	9	12	305	11	279	0.38	9.7	0.4	10	20.5	9.3
909983	11 ¼	13	330	11	279	0.50	12.7	0.56	14	12.1	5.5

* Part Numbers for the Base Plate only and does not include Turning Handles. Part Numbers for 5, 6 ¾, and 9 inch Base Plates are for white powder coat finish. Part Number for 11 ¼ inch Base Plate is for clear anodize finish. Additional finishes are available. The appearance of the 11 ¼ Base Plate will be slightly different.

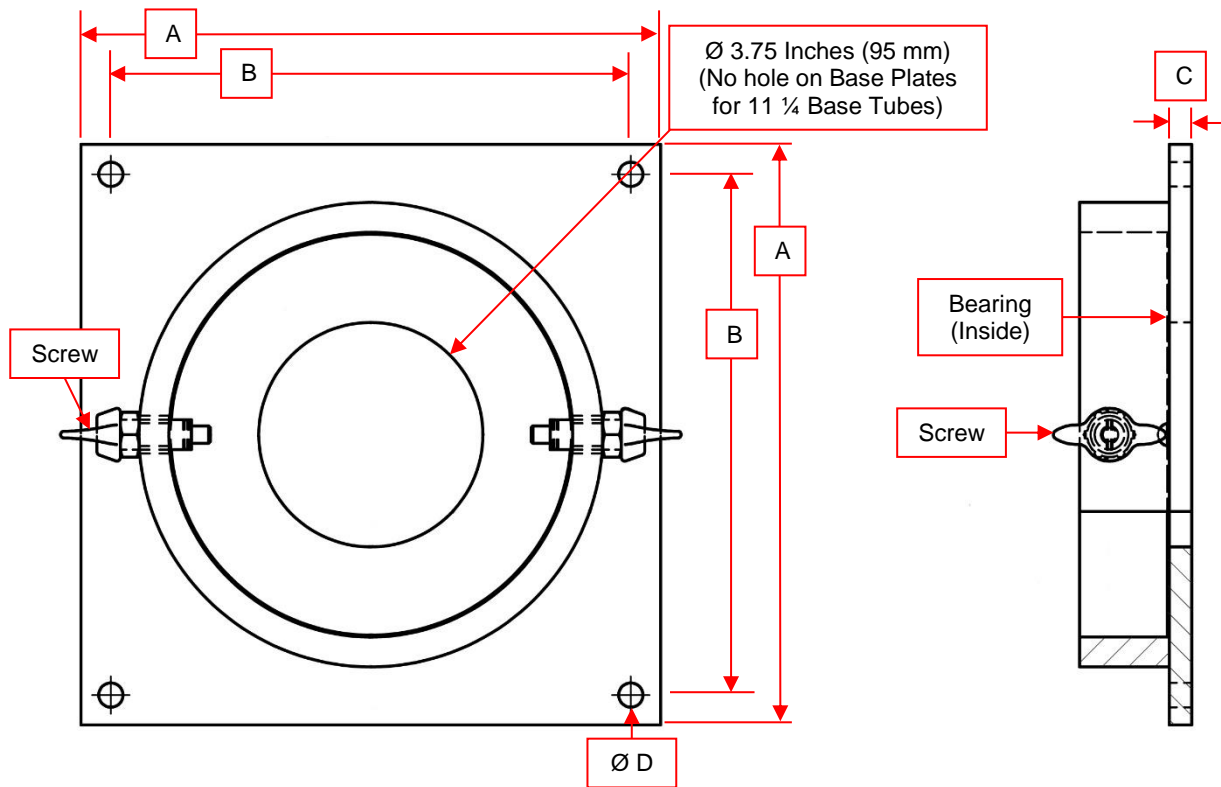

Figure 2-5 Rotating Base Plate Installation Specifications (P/N: 902492 Shown)

2.6.4 Turning Handle Assembly Installation Specifications

Table 2-7 Turning Handle Assembly Installation Specifications

P/N*	Base Tube	A	
		inch	mm
908174	5	14	356
914480	6 ¾	16	406
906813	9	18	457

* Part Number is for the Turning Handles only and does not include the Base Plate. Part Numbers listed have a black paint finish. Additional finishes are available.

Note: Rotatable masts with 11 ¼ Base Tubes do not come standard with Turning Handles.

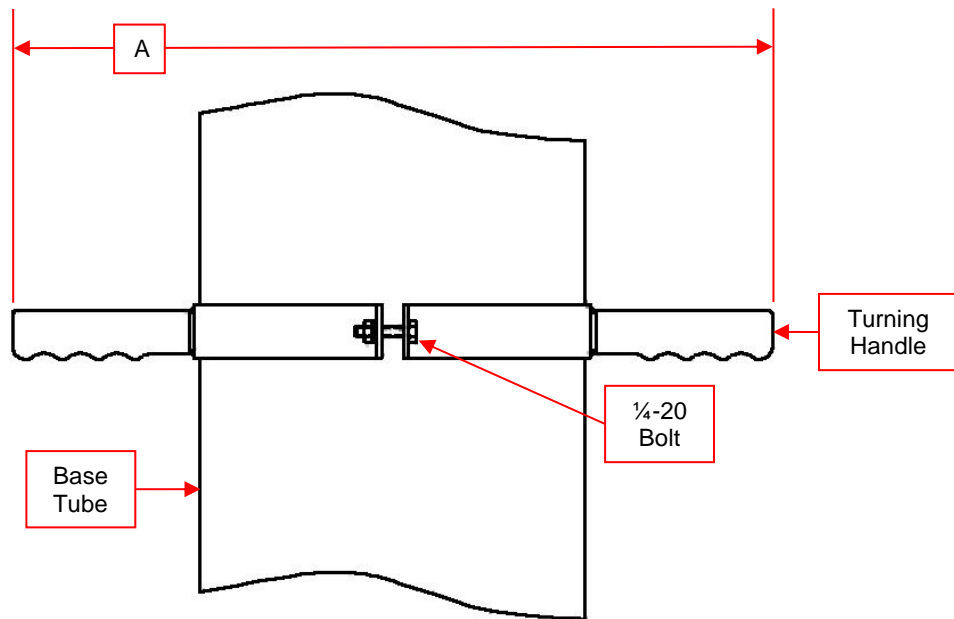

Figure 2-6 Turning Handle Assembly Installation Specifications

2.6.5 Internal Mounting Kit Installation Specifications

Table 2-8 Internal Mounting Kit (Roof Flange and Roof Ring) Installation Specifications

P/N*	Base Tube	Ø A		B	C		D		Ø BCD	
		inch	mm		inch	mm	inch	mm	inch	mm
905735	5	9	229	6	1.9	48.3	0.25	6.4	8	203
905734	6 ¾	9 ¾	248	8	1.9	48.3	0.25	6.4	8 ¾	222
905733	9	12	305	8	1.9	48.3	0.25	6.4	11	279
910784	11 ¼	14.25	362	8	1.8	45.7	0.25	6.4	13	330

* Part Numbers for clear anodized finish. Additional finishes are available.

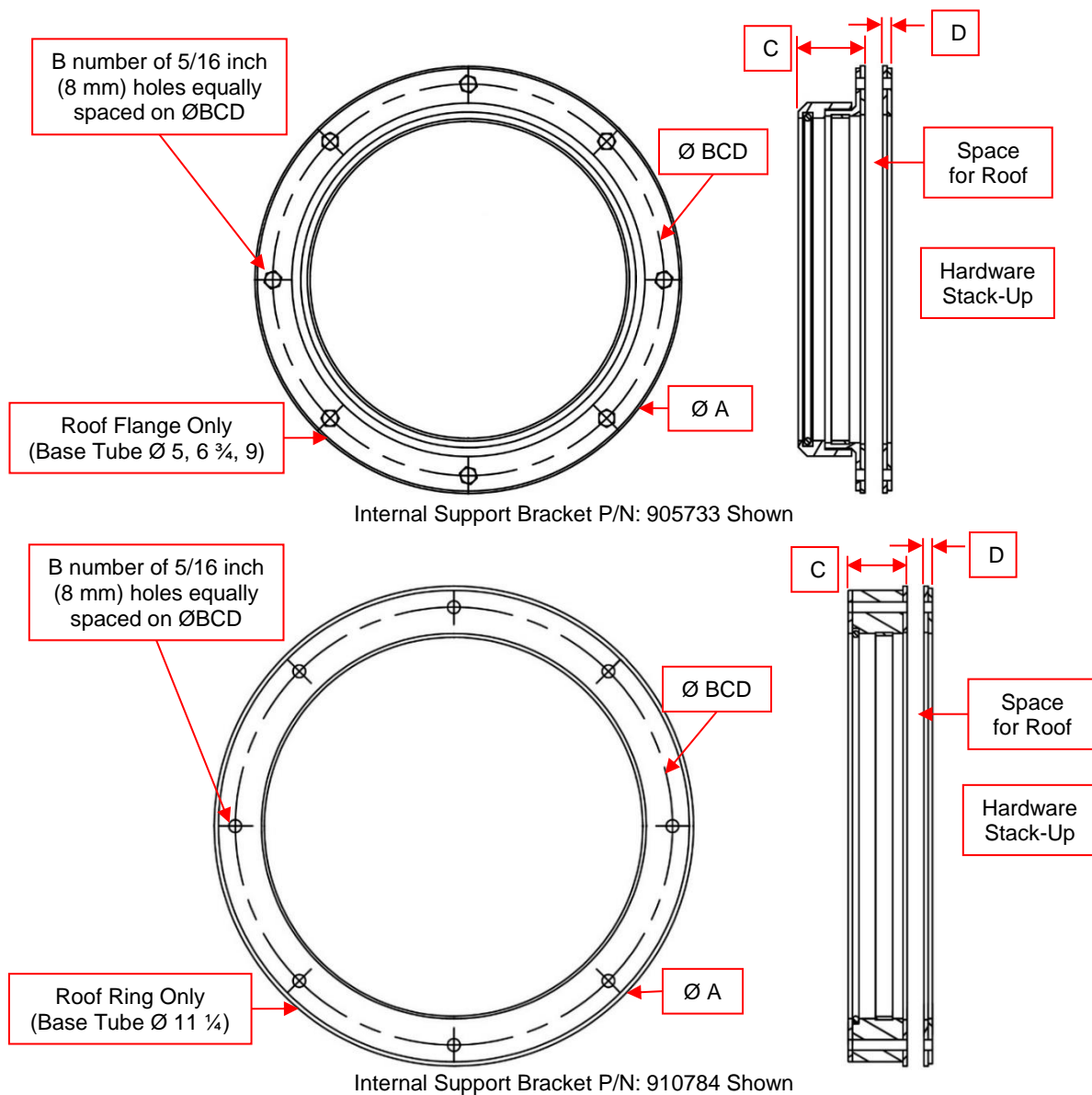

Figure 2-7 Internal Mounting Kit Hardware Installation Specifications

2.6.6 Support Bracket Assembly Installation Specifications

Table 2-9 Support Bracket Assembly (Standard and Heavy-Duty) Installation Specifications

P/N*	Base Tube	OD		A		B		Estimated Weight	
		inch	mm	inch	mm	inch	mm	lb.	kg
4443601	5	6	152	7 ½	191	11.24	285	5.7	2.6
4443605	6 ¾	7 ¾	197	8 ¼	210	12.10	307	6.7	3
4443615	9	10 ½	267	9 ¾	248	13.84	352	12.1	5.5

* Part Numbers for clear anodized finish. Additional finishes are available.

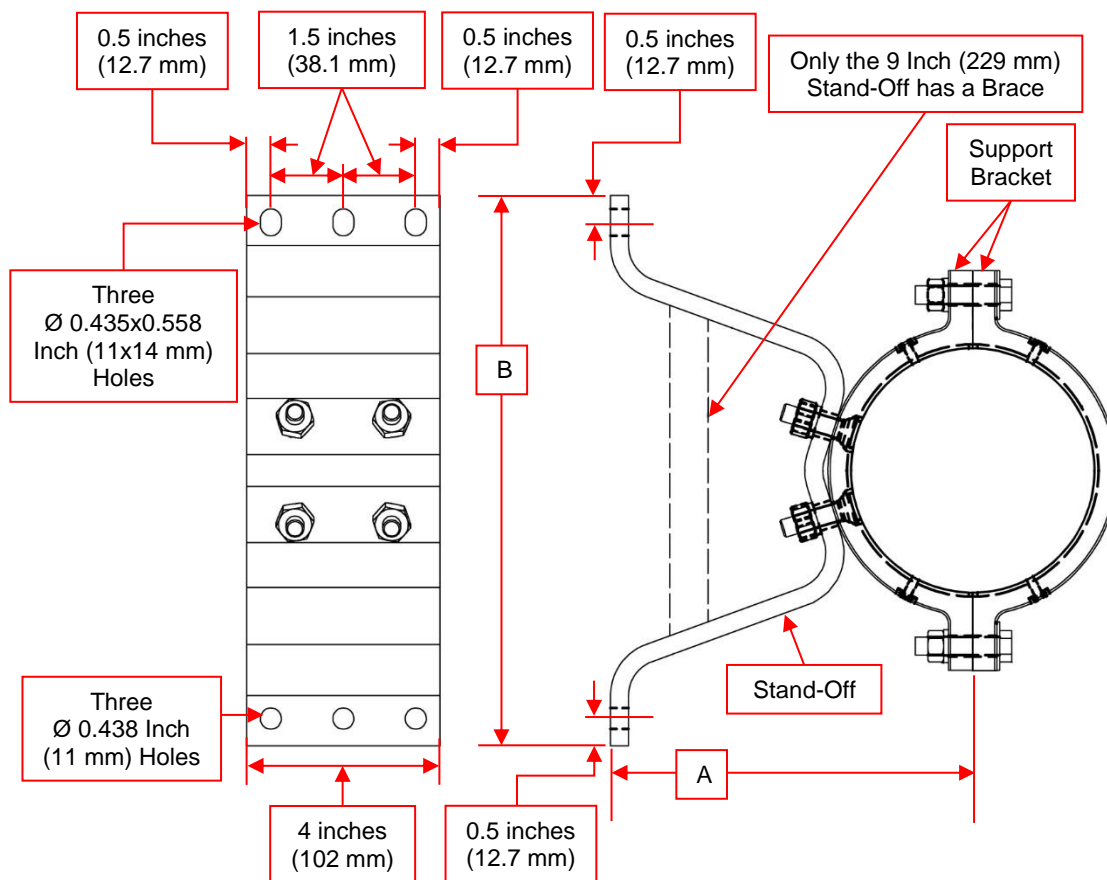

Figure 2-8 Support Bracket Assembly (Standard and Heavy-Duty) Installation Specifications (P/N: 4443601 Shown)

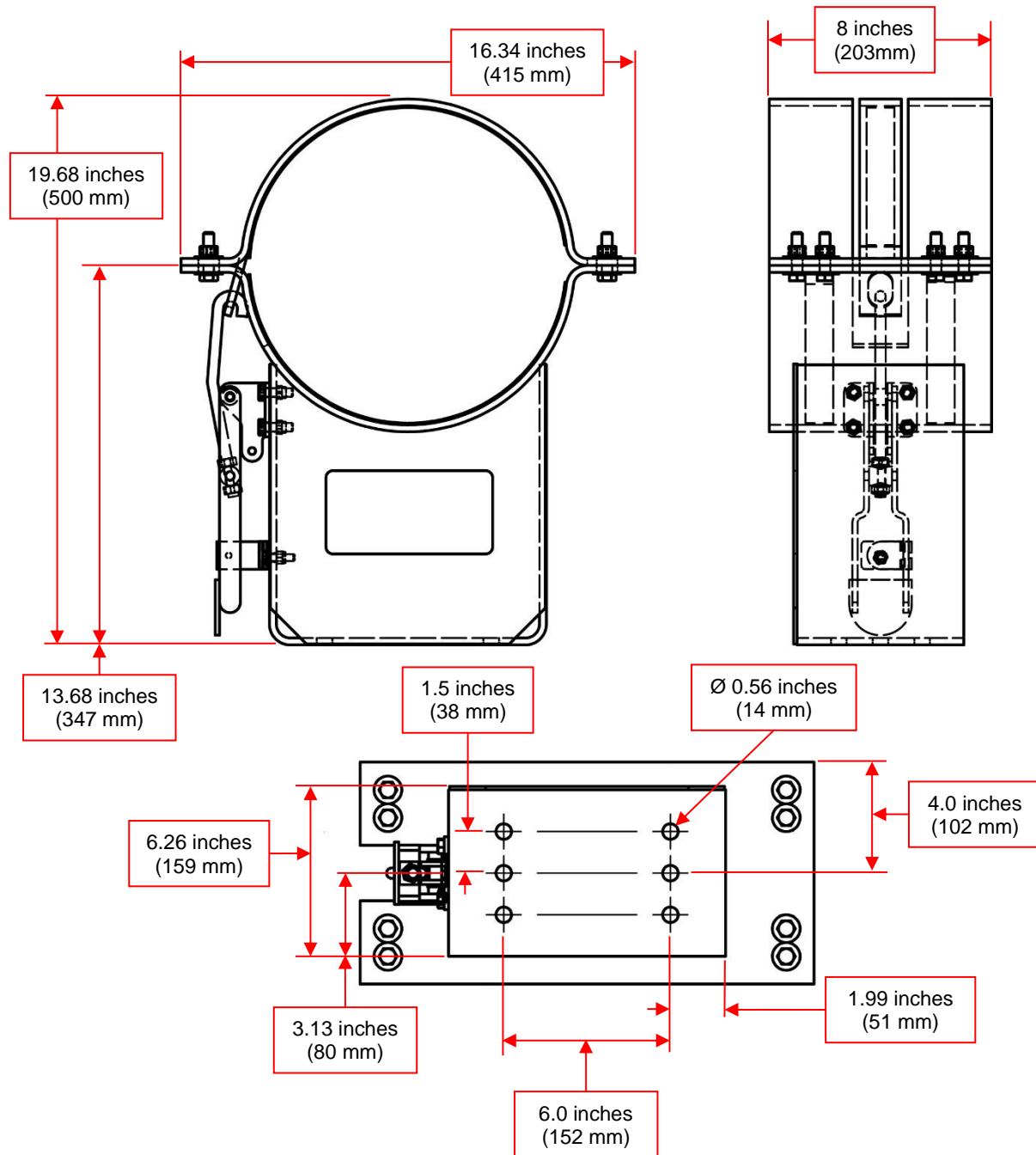

Figure 2-9 Support Bracket Assembly (Super-Heavy-Duty) Installation Specifications (P/N: 909984 Shown)

Note: Part Number 909984 is for a black powder coat finish. Additional finishes are available.

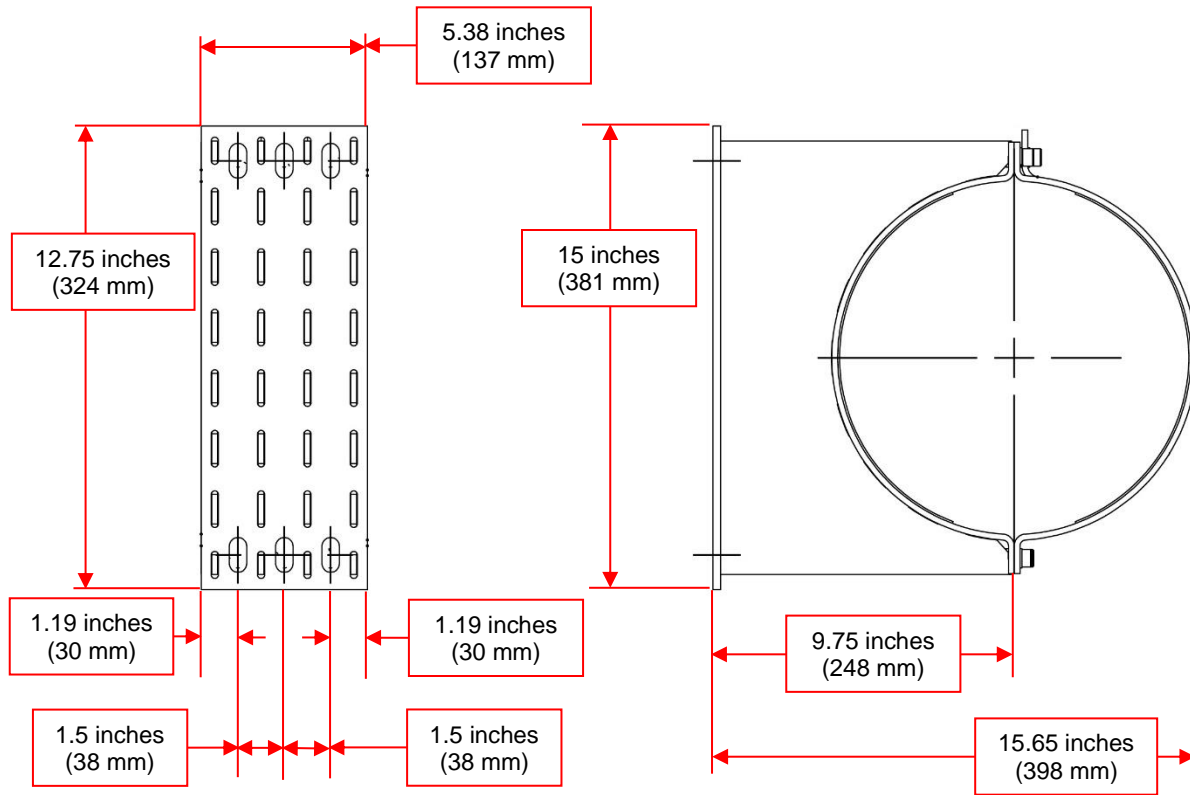

Figure 2-10 Support Bracket Assembly (Super-Heavy-Duty) Installation Specifications (P/N: 4894901 Shown)

Note: Part Number 4894901 is for a black powder coat finish. Additional finishes are available.

2.6.7 Shelf Bracket Assembly Installation Specifications

Table 2-10 Shelf Bracket Assembly Specifications

P/N*	Base Tube	Base Plate**	A		B		C		D		E	
			inch	mm	inch	mm	inch	mm	inch	mm	inch	mm
4434101	5	NR	8.0	203	11.8	300	6.0	152	10.5	267	6.5	165
4434101		R	8.0	203	11.8	300	6.0	152	10.5	267	6.5	165
4434101	6 ¾	NR	8.0	203	11.8	300	6.0	152	10.5	267	6.5	165
4454001		R	9.8	249	14.38	365	7.75	197	11.95	304	8.44	214
4454001	9	NR	9.8	249	14.38	365	7.75	197	11.95	304	8.44	214
4454101		R	10.0	254	15.88	403	8.0	203	14.5	368	10.75	273
913947	11 ¼	Both	12.0	305	20.25	514	8.0	203	14.5	368	10.24	260

P/N*	Base Tube	Base Plate**	F		G		H		J		K	
			inch	mm	inch	mm	inch	mm	inch	mm	inch	mm
4434101	5	NR	4.3	109	0.44	11	3.75	95	5.26	134	7.87	200
4434101		R	4.3	109	0.44	11	3.75	95	5.26	134	7.87	200
4434101	6 ¾	NR	4.3	109	0.44	11	3.75	95	5.26	134	7.87	200
4454001		R	6.0	152	0.56	14	5.25	133	5.98	152	9.0	229
4454001	9	NR	6.0	152	0.56	14	5.25	133	5.98	152	9.0	229
4454101		R	6.3	160	0.56	14	3.75	95	7.3	185	9.75	248
913947	11 ¼	Both	6.0	152	0.56	14	4.0	102	7.19	183	13.75	349

P/N*	Base Tube	Base Plate**	L		M		N		P	
			inch	mm	inch	mm	inch	mm	inch	mm
4434101	5	NR	2.75	70	2.14	54	4.25	108	0.44	11
4434101		R	1.38	35	0.77	20	7.0	178	0.44	11
4434101	6 ¾	NR	2.0	51	0.64	16	5.75	146	0.44	11
4454001		R	1.25	32	1.8	46	8.7	221	0.44	11
4454001	9	NR	1.6	41	0.63	16	8.0	203	0.44	11
4454101		R	1.38	35	0.62	16	11.0	279	0.44	11
913947	11 ¼	Both	1.38	35	1.0	25	11.0	279	0.56	14

* Part Numbers for 5, 6 ¾, and 9 inch Base Plates are for clear anodize finish. Part Number for 11 ¼ inch Base Plate is for black powder coat finish. Additional finishes are available.

** Non-Rotating (NR) and Rotating (R)

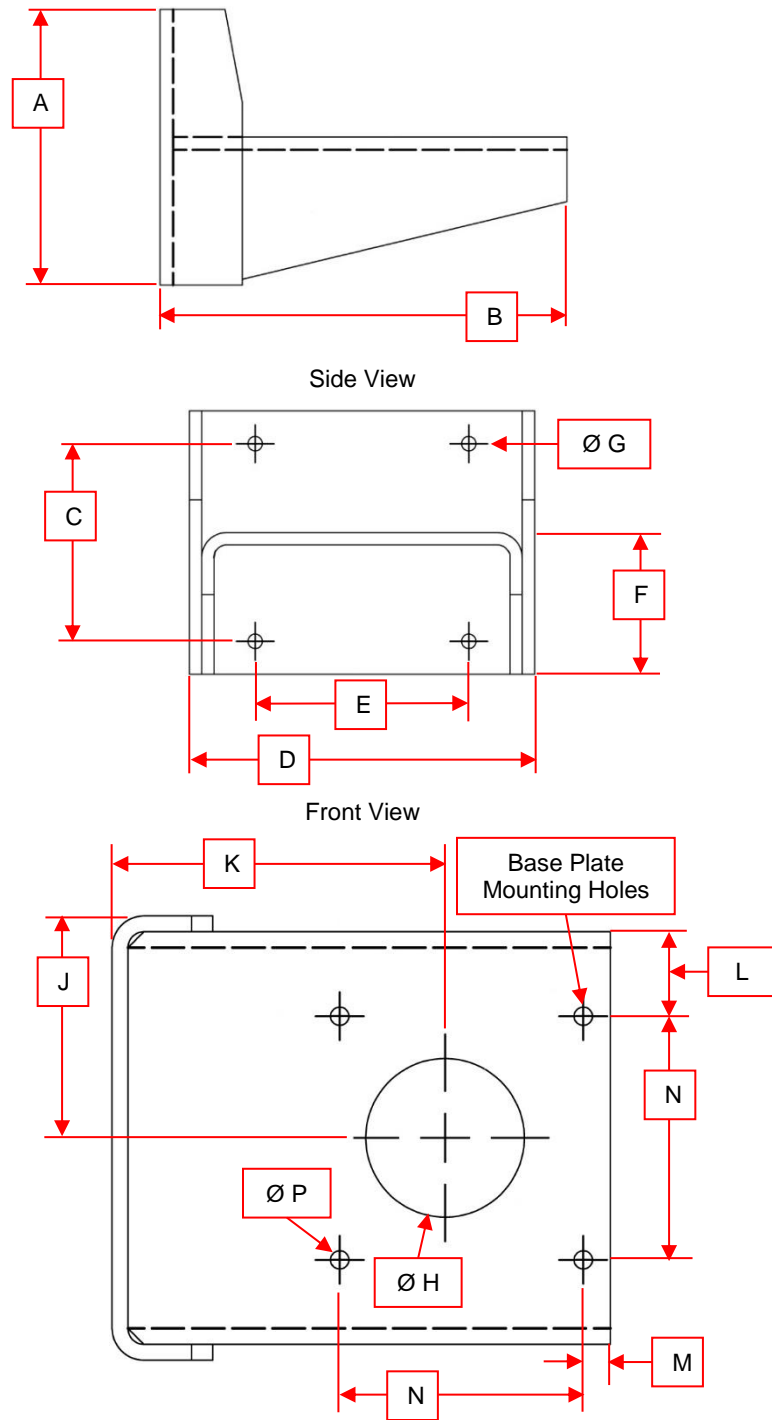

Top Down View (Mounting Hole Pattern Shown in Simplified Form)

Figure 2-11 Shelf Bracket Installation Specifications

Note: For clarity purposes, the Base Plate Mounting Hole pattern shown (Figure 2-11) has been simplified. Actual Shelf Brackets may have multiple sets of Base Plate Mounting Holes in order to accommodate multiple mast types. Use the set of Base Plate Mounting Holes appropriate for your Mast System.

2.7 Mast Installation: Internal Mount

This section describes installation of an internally mounted mast (Figure 2-12). These internal mounting instructions assume the use of an Internal Mounting Kit (Section 1.5.3.2). For information on mounting the mast externally, see Section 2.8.

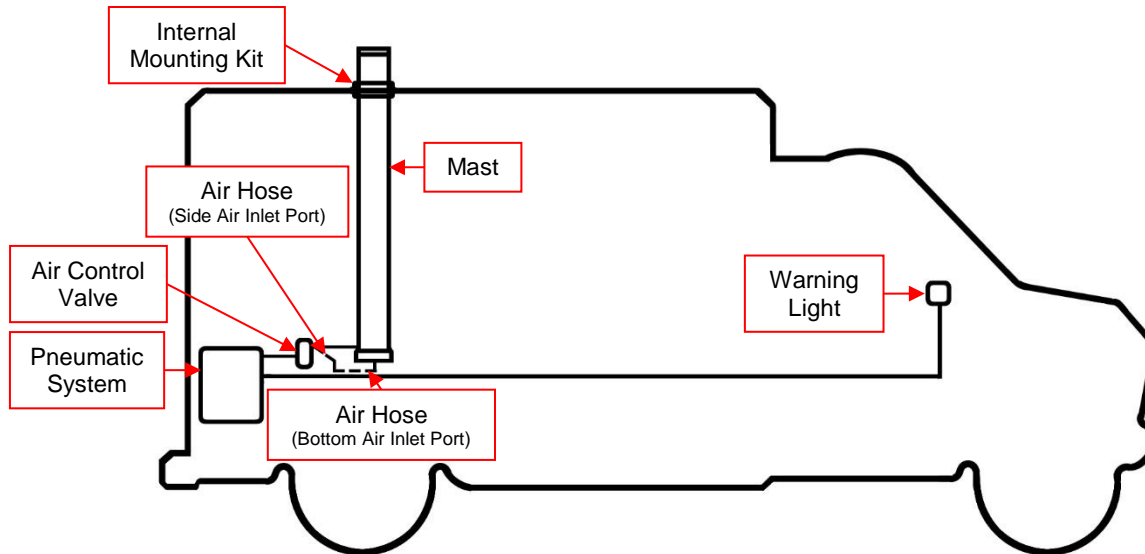

Figure 2-12 Internal Mount Installation (Not to Scale)

2.7.1 Internal Mount: Quick Summary

The following is a quick summary of the installation of an internally mounted mast. Detailed steps follow the quick summary (Section 2.7.2).

Install an internally mounted mast as follows:

1. Select a Suitable Mounting Location (Section 2.7.2.1)
2. Begin Installation of the Internal Mounting Kit (Section 2.7.2.2)
3. Lower Mast through the Internal Mounting Kit (Section 2.7.2.3)
4. Attach the Base Plate to the Mast (Section 2.7.2.4)
5. Position the Mast (Section 2.7.2.5)
6. Secure the Base Plate to the Mounting Surface (Section 2.7.2.6)
7. Complete Installation of the Internal Mounting Kit (Section 2.7.2.7)
8. Finalize Installation of the Mast System (Section 2.7.2.8)

2.7.2 Internal Mount: Detailed Instructions

The following are detailed steps describing the installation of an internally mounted mast. The exact installation procedures may vary based on the configuration of the Mast System being used and the installation environment.

2.7.2.1 Select a Suitable Mounting Location

To select a suitable mounting location, consider the following:

- The mounting area must have sufficient room to mount the Mast System. The roof area must be as flat as possible at the location of the mast. The roofline must lie between the Drain Hole and Base Tube Collar. Mounting hardware must be at least 1 inch (25 mm) above the Drain Hole, and at least 3 inches (76 mm) below the Base Tube Collar (Figure 2-13). The exact dimensions of the Mast System will vary based on the components included. Refer to Section 2.6 for dimension information.

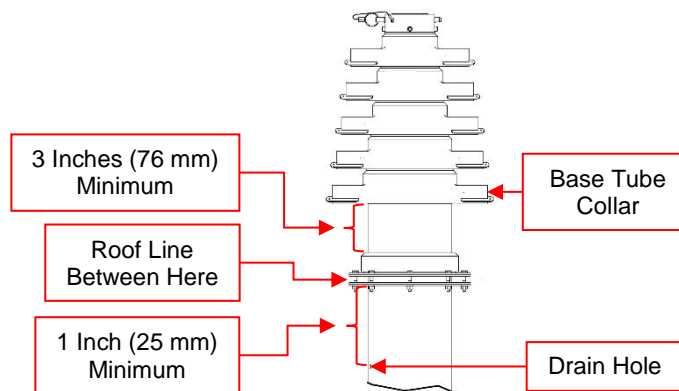

Figure 2-13 Roof Line Location (Not to Scale)

- The mounting structure must be level, solid, and capable of holding the forces required by the bolts. Check the strength and rigidity of the mounting structure (e.g. vehicle body) where the Mast System is to be attached. Reinforce as necessary.
- The area underneath the mast must be free of obstructions to allow for accessibility to Base Plate fasteners, and if present and used, the Bottom Air Inlet Port.
- The mounting location must have sufficient access for the Pneumatic System.
- Before cutting the hole in the roof, it is advised to hang a plumb-bob from the roof to find the Base Plate location and ensure proper alignment between the roof hole and intended Base Plate location. This is particularly helpful when attempting to hit specific structural members beneath a vehicle.
- For mounting applications using a Rotatable Base Plate, ensure the location of the mast allows enough clearance to accommodate the Turning Handles and the Air Hose if the air is routed to a Side Air Inlet Port. Rotatable Super-Heavy-Duty masts do not use Turning Handles, but will need clearance for a customer-supplied rod to be inserted into the Tube Head to turn the mast.
- As mast tubes extend, they force water out of the weep holes. Keep any personnel or sensitive equipment away from the weep hole direction.

2.7.2.2 Begin Installation of the Internal Mounting Kit

To begin installation of the Internal Mounting Kit:

1. Remove any roof liner or ceiling panels from the roof.
2. Cut a round hole in the roof $\frac{1}{4}$ inch (6.35 mm) larger than the diameter of the Base Tube (Section 1.4). Cut the same size hole in any roof liner or ceiling panels ensuring the hole will properly align with the hole in the roof when the roof liner or ceiling panels are reinstalled.
3. Center the Ceiling Plate from the Internal Mounting Kit (Figure 2-14 or Figure 2-15) over the hole and use it as a template to drill bolt holes for attachment.

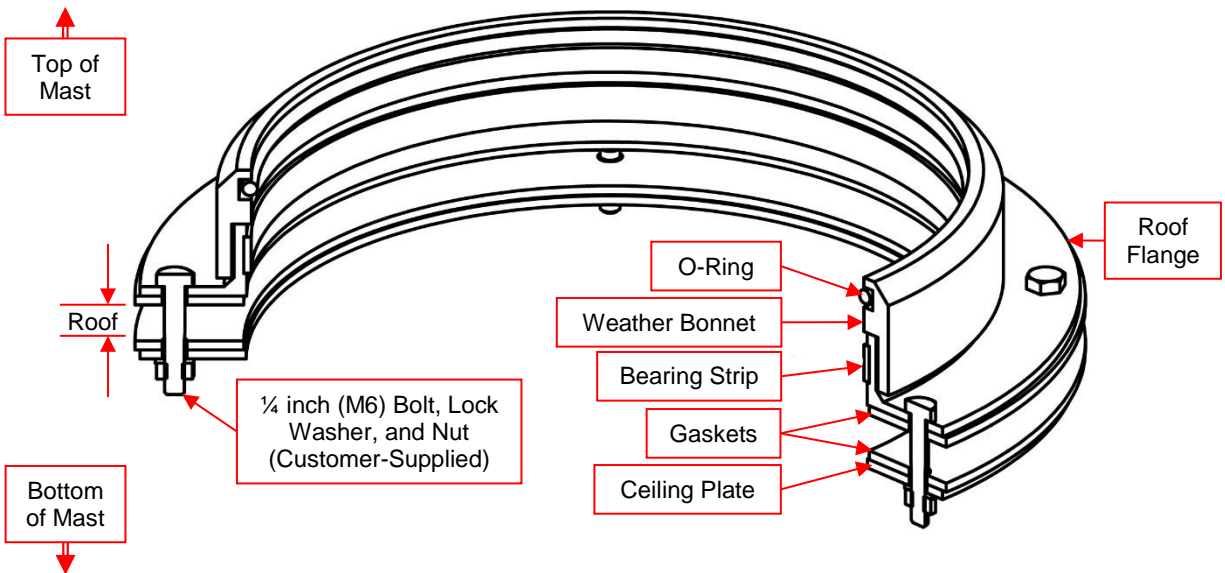

Figure 2-14 Internal Mounting Kit for Standard-Duty and Heavy-Duty Masts (P/N: 905733 Shown)

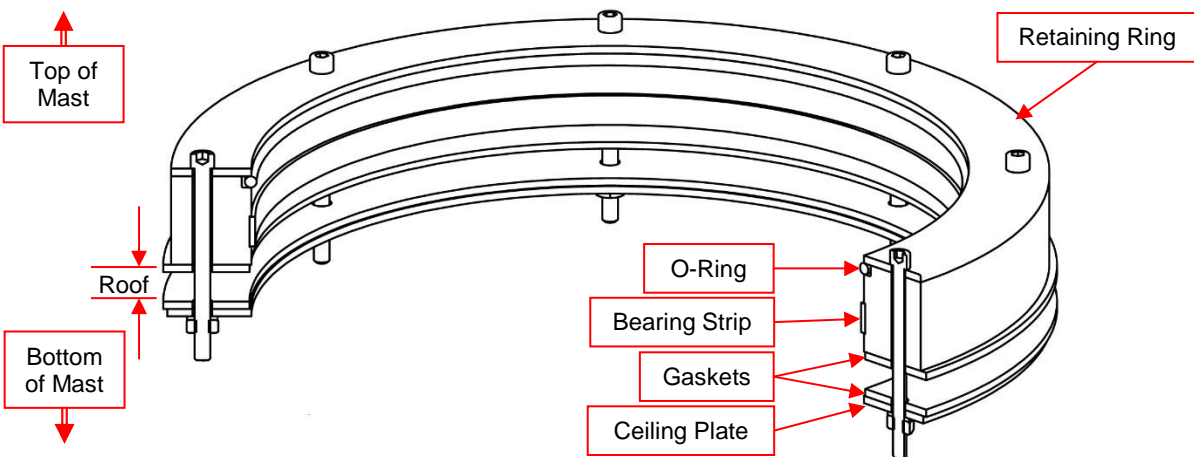

Figure 2-15 Internal Mounting Kit for Super-Heavy-Duty Masts (P/N: 910784 Shown)

4. If necessary, use washers or short spacers made of $\frac{1}{4}$ inch (6.35 mm) pipe to level out any irregularities that exist in the roof.
5. Apply a bead of silicone sealant to both sides of one Gasket.
6. For Standard-Duty and Heavy-Duty Masts:
 - a. Line up the holes of the roof, the Gasket with silicone sealant applied, and the Roof Flange (Figure 2-14). Ensure the Gasket is between the roof and Roof Flange.
 - b. Replace any roof liner or ceiling panel.
 - c. Fit the other Gasket (Figure 2-14) against the inside of the roof. This Gasket does not need sealant. It will be held in place by the Ceiling Plate. Fit the Ceiling Plate in place and ensure all holes align.
 - d. Fasten this assembly (Figure 2-16) together using:
 - i. $\frac{1}{4}$ Inch (M6) Bolts
 - ii. $\frac{1}{4}$ Inch (M6) Lock Washers
 - iii. $\frac{1}{4}$ Inch (M6) Nuts

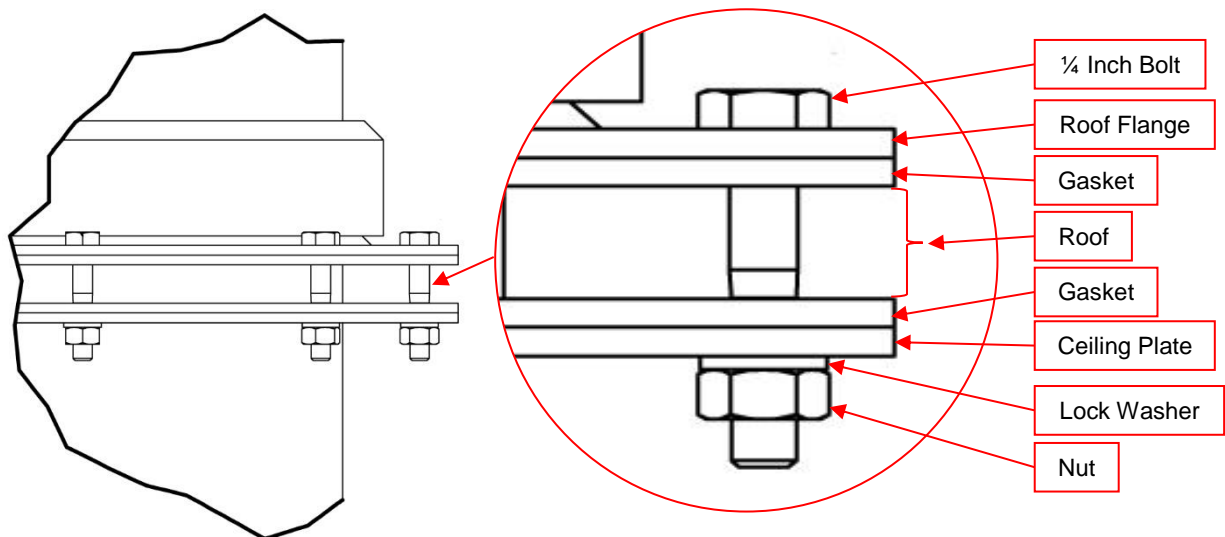

Figure 2-16 Fasten Assembly Together

The bolts should be sized to length to account for all components. The mounting hardware must include proper means to resist vibration loosening such as thread-locking compound or locking hardware. Torque all hardware as appropriate for its size and grade.

Note that the Weather Bonnet and O-Ring are not yet installed (Figure 2-14).

- e. Clean off any silicone sealant that may have squeezed out the hole cut for the mast.

- f. Slide the Weather Bonnet and O-Ring over the bottom of the Base Tube and up the mast past the drain hole towards the collar. If they are difficult to maneuver, put soapy water on the mast to allow them to slide more freely. Ensure the Weather Bonnet is oriented correctly and the O-Ring is in the notch in the Weather Bonnet (Figure 2-14).
- g. Temporarily secure the Weather Bonnet and O-Ring in place so they cannot slide down the mast during transportation.
- h. Go to Section 2.7.2.3.

For Super-Heavy-Duty Masts:

- a. Line up the holes in the roof, Gasket, and Roof Ring (Figure 2-15). Ensure the Gasket is between the roof and Roof Ring.

For Non-Rotatable Mast System, leave the Retaining Ring and O-Ring off. These will be installed later.

For Rotatable Mast Systems, line up the holes in the Retaining Ring. Rotatable Mast Systems will have Flashing Kit instead of an O-Ring. The Flashing Kit will be installed later.

- b. Replace any roof liner or ceiling panel.
- c. Fit the other Gasket (Figure 2-15) against the inside of the roof. This Gasket does not need sealant. It will be held in place by the Ceiling Plate. Fit the Ceiling Plate in place and ensure all holes align.
- d. For Non-Rotatable Mast Systems, temporarily secure this assembly together. Do not torque hardware. Hardware will be torqued during final assembly.

For Rotatable Mast Systems, fasten the assembly (Figure 2-17) together using:

- i. (8) ¼ inch (M6) Bolts
- ii. (8) ¼ inch (M6) Lock Washers
- iii. (8) ¼ Inch (M6) Nuts

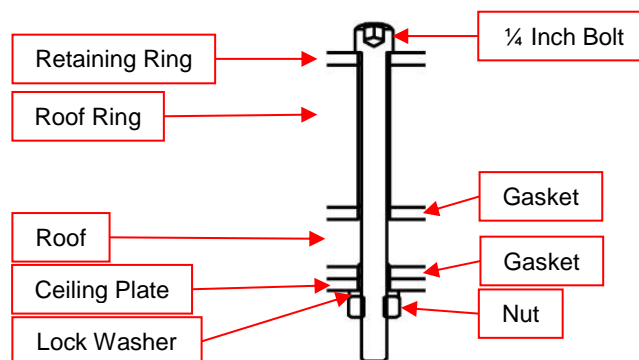

Figure 2-17 Fasten Assembly Together

The mounting hardware must include proper means to resist vibration loosening such as thread-locking compound or locking hardware. Torque all hardware as appropriate for its size and grade.

- e. Clean off any silicone sealant that may have squeezed out into the hole cut for the mast.
- f. For Non-Rotatable Mast Systems, slide the Retaining Ring and O-Ring over the bottom of the Base Tube and up the mast past the Drain Hole towards the collar. If they are difficult to maneuver, put soapy water on the mast to allow them to slide more freely. Ensure the O-Ring is below the Retaining Ring. Temporarily secure the Retaining Ring and O-Ring in place so they cannot slide down the mast during transportation.

For Rotatable Mast Systems, no actions are required at this time for the Flashing Kit. The Flashing Kit will be installed in Section 2.7.2.7.

2.7.2.3 Lower Mast through the Internal Mounting Kit

To lower the mast through the Internal Mounting Kit:

1. Use a hoist to slowly lift the mast above the roof.
2. Align the base of the mast with the center hole of the Internal Mounting Kit.
3. Carefully lower the mast partially through the roof. The mast should be held securely in position partially through the roof so that the installer has safe access to the base of the mast to install the Base Plate.

2.7.2.4 Attach the Base Plate to the Mast

The mast may use either a Non-Rotatable or Rotatable Base Plate. Follow the appropriate installation instructions for your Mast System. When installing the Base Plate to the base of the mast, ensure the mast is securely held in position.

⚠ WARNING

Crush Hazard – Hoist Failure! Use extreme caution while installing the Base Plate to the mast. Be certain mast is properly secured during installation of Base Plate. Death or serious injury could occur if hoist fails or mast slips suddenly.

Non-Rotatable Base Plates

To install a Non-Rotatable Base Plate:

1. Position the Base Plate against the base of the mast so the mounting holes align. Ensure the countersunk holes are facing away from the mast.
2. Secure the Base Plate to the mast with the (4) $\frac{3}{8}$ -16x1 flathead screws (P/N: 2772) from the Hardware Bag. Apply Loctite® 242/243 (Blue) or equivalent. Torque to 190-240 in.-lb.

Rotatable Base Plates

To install a Rotatable Base Plate:

1. Back the Locking Screws far enough out of the Base Plate to allow the Base Plate to fit over the end of the mast.
2. Slide the Base Plate over end of the mast.
3. Tighten down the Locking Screws to secure the Base Plate to the mast.

2.7.2.5 Position the Mast

To position the mast:

1. Lower the mast the rest of the way to the floor.
2. Carefully, move the mast into position ensuring the mast is level. It is necessary to check the mast in two places 90° apart when leveling. Be certain to orient the mast so the operator has a clear view of the hazard labels.

Note: Additional labels are provided with the operator's manual and should be installed where the operator will have a clear view of them while operating the mast.

2.7.2.6 Secure the Base Plate to the Mounting Surface

To secure the Base Plate to the mounting surface:

1. Use the Base Plate as a template to drill holes through the mounting surface.
2. Ensure the Base Plate and mast are level in all directions. It is necessary to check the mast in two places 90° apart when leveling.
3. Secure the Base Plate to the mounting surface with appropriate hardware. To secure the Base Plate, the Hardware Bag contains:
 - a. (4) $\frac{3}{8}$ -16x1- $\frac{1}{2}$ Inch Bolts (P/N: 901594)
 - b. (4) Flat Washers (P/N: 2054)
 - c. (4) Lock Washers (P/N: 0801)
 - d. (4) Nuts (P/N: 901593)

Depending on the customer-specific mounting application, other (customer-supplied) hardware may be required. The mounting hardware must include proper means to resist vibration loosening such as thread-locking compound or locking hardware. Torque to 190-240 in.-lb.

2.7.2.7 Complete Installation of the Internal Mounting Kit

This section describes completing the installation of the Internal Mounting Kit as follows:

- Non-Rotatable Standard-Duty and Heavy-Duty Masts
- Non-Rotatable Super-Heavy-Duty Masts
- Rotatable Standard-Duty and Heavy-Duty Masts
- Rotatable Super-Heavy-Duty Masts
- Turning Handles

The exact installation procedures will vary depending on the configuration of the Mast System. Follow the appropriate installation instructions for your configuration.

Non-Rotatable Standard-Duty and Heavy-Duty Masts

To complete installation, slide the Weather Bonnet, with the O-Ring in the notch, down the mast and over the Roof Flange. If the Weather Bonnet is difficult to maneuver, put soapy water on the mast to allow them to slide more freely.

Non-Rotatable Super-Heavy-Duty Masts

To complete installation:

1. Remove the hardware securing the Roof Ring ensuring the Ceiling Plate and Gasket underneath the roof do not fall.
2. Slide the Retaining Ring and O-Ring down the mast.
3. Press the O-Ring into the notch around the Roof Ring.
4. Position the Retaining Ring into place ensure all the holes of the Internal Mounting Kit align with the holes in the roof.
5. Fasten this assembly (Figure 2-18) together using:
 - a. (8) ¼ Inch (M6) Bolts
 - b. (8) ¼ Inch Lock Washers
 - c. (8) ¼ Inch Nuts

The mounting hardware must include proper means to resist vibration loosening such as thread-locking compound or locking hardware. Torque all hardware as appropriate for its size and grade.

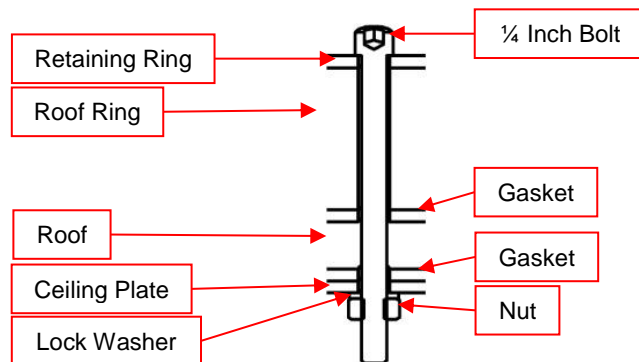

Figure 2-18 Fasten Assembly Together

Rotatable Standard-Duty and Heavy-Duty Masts

To complete installation, slide the Weather Bonnet, with the O-Ring in the notch, down the mast and over the Roof Flange. If the Weather Bonnet is difficult to maneuver, put soapy water on the mast to allow it to slide more freely.

Rotatable Super-Heavy-Duty Masts

This section describes installing the Flashing Kit. If retrofitting a mast to use a Flashing Kit, see *Installing the Internal Mount Flashing Kit* (TP-5351001). To obtain this document, contact The Will-Burt Company.

To complete installation:

1. With the paper on the tape, position the Flashing Halves around the mast, allowing the Flashing Halves to rest on the internal mount.
2. Raise the Flashing Halves $\frac{1}{8}$ inch (3 mm).
3. Ensure there will be no obstructions with the sealant or roof line when the mast rotates and mark the top of the Flashing Halves with a pencil.
4. Remove the paper from the tape, and position the Flashing Halves so they align with the pencil mark.
5. Secure the Flashing tight to the mast with:
 - a. (6) $\frac{1}{4}$ -20x0.75 Inch Bolts (P/N: 4542)
 - b. (12) $\frac{1}{4}$ Flat Washers (P/N: 0800)
 - c. (6) Nyloc Nuts (P/N: 1930)

Do not overtighten the Flashing Kit as tightening too much can deform the Base Tube and impede the movement of the next internal section.

6. Inspect the seal and add any tape if required.

Turning Handles

Turning Handles ship with Rotatable Base Plates to assist in rotating the mast. Note that Rotating Super-Heavy-Duty masts do not use Turning Handles.

CAUTION

Equipment Damage – Band Clamp Fasteners! Do not overtighten the Band Clamp fasteners. Overtightening may damage the Base Tube causing the mast tubes to stick.

To secure the Turning Handles:

1. Determine the desired location for the Turning Handles. If feasible, Will-Burt recommends installing above the Drain Hole. Do not cover Drain Hole with the Turning Handles.

2. Secure the Band Clamp Halves together around the mast with
 - (2) ¼-20x1.50 Hex HD Bolts (P/N: 2000)
 - (2) ¼-20 Nyloc Nuts (P/N: 1930)

Tighten the Turning Handle bolts just enough to allow the Turning Handles to turn the mast without slipping. Overtightening the Turning Handle bolts can deform the Base Tube and impede the movement of the next internal section.

For masts with:

- Ø 5.00 Inch Base Tube: Torque to 60 in.-lb. Maximum
- Ø 6.75 Inch Base Tube: Torque to 100 in.-lb. Maximum
- Ø 9.00 Inch Base Tube: Torque to 120 in.-lb. Maximum

The mounting hardware must include proper means to resist vibration loosening such as thread-locking compound or locking hardware.

2.7.2.8 Finalize Installation of Mast System

Once the mast is installed, see Section 2.9 for information on the installation of the following components:

- Drain Kit Installation (Section 2.9.1)
- Pneumatic System Installation (Section 2.9.2)
- Magnetic Warning Kit Installation (Section 2.9.3)

2.8 Mast Installation: External Mount

This section describes installation of an externally mounted mast (Figure 2-19). The external mounting instructions assume the use of an External Support Bracket. For information on mounting the mast internally, see Section 2.7.

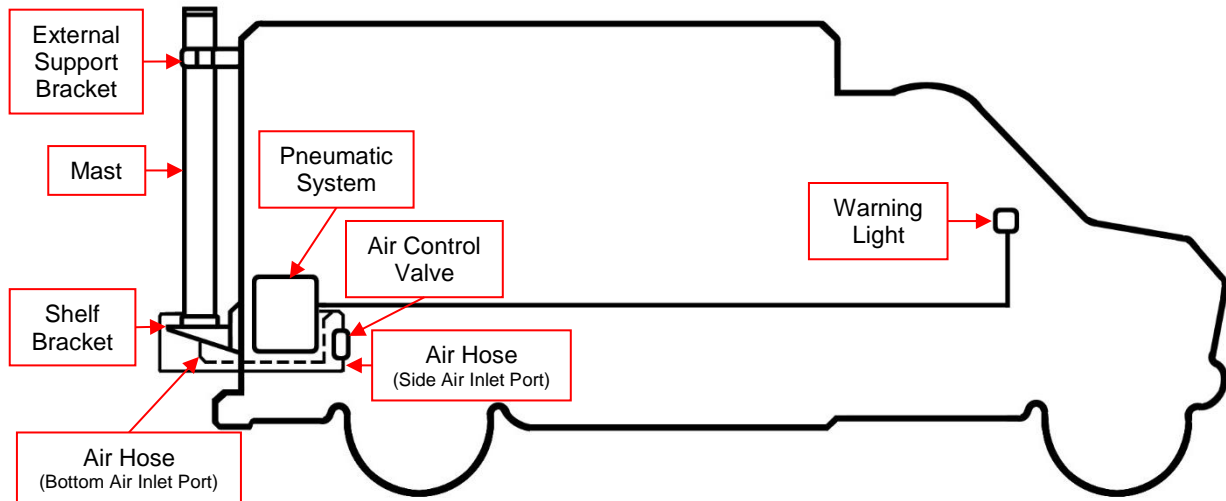

Figure 2-19 External Mount Installation (Not to Scale)

2.8.1 External Mount: Quick Summary

The following is a quick summary of installation of an externally mounted mast. Detailed steps follow the quick summary (Section 2.8.2).

Install an externally mounted mast as follows:

1. Select a Suitable Mounting Location (Section 2.8.2.1)
2. Install the Shelf Bracket (Optional) (Section 2.8.2.2)
3. Attach the Base Plate to the Mast (Section 2.8.2.3)
4. Position the Mast (Section 2.8.2.4)
5. Install the External Support Bracket (Section 2.8.2.5)
6. Secure the Base Plate to the Mounting Surface (Section 2.8.2.6)
7. Install the Turning Handles (Rotatable Mast Systems Only) (Section 2.8.2.7)
8. Finalize Installation of Mast System (Section 2.8.2.8)

2.8.2 External Mount: Detailed Instructions

The following are detailed steps of installation of an externally mounted mast. The exact installation procedures may vary based on the configuration of the Mast System being used and the installation environment.

2.8.2.1 Select a Suitable Mounting Location

When selecting a suitable mounting location, consider the following:

- The mounting area must have sufficient room to mount the Mast System. Mounting hardware must be at least 1 inch (25 mm) above the Drain Hole and at least 1 inch (25 mm) below, but close to, the Base Tube Collar (Figure 2-20). Do not cover the Drain Hole. The exact dimensions of the Mast System will vary based on the components included. Refer to Section 2.6 for dimension information.

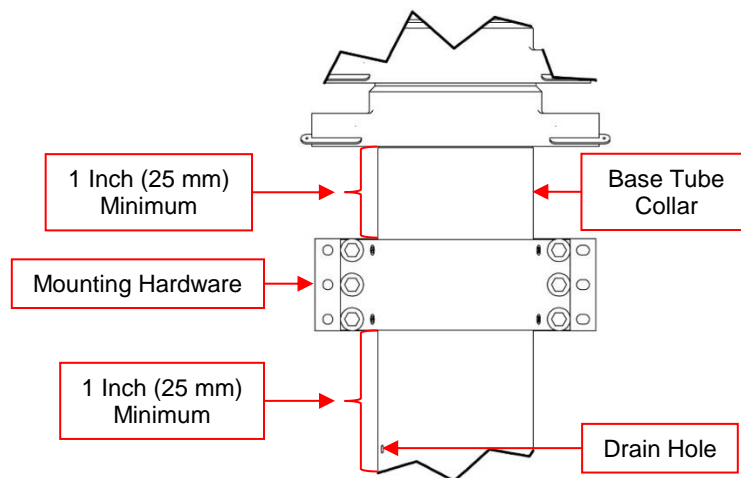

Figure 2-20 Mounting Hardware Location (Not to Scale)

- The mounting structure must be level, solid, and capable of holding the forces required by the bolts. Check the strength and rigidity of the mounting structure (e.g. vehicle body) where the Mast System is to be attached. Reinforce as necessary.
- The area underneath the mast must be free of obstructions to allow for accessibility to Base Plate fasteners, and if present and used, the Bottom Air Inlet Port.
- The mounting location must have sufficient access for the Pneumatic System.
- For mounting applications using a Rotatable Base Plate, ensure the location of the mast allows enough clearance to accommodate the Turning Handles and the Air Hose if the air is routed to a Side Air Inlet Port. Rotatable Super-Heavy-Duty masts do not use Turning Handles, but will need clearance for a customer-supplied rod to be inserted into the Tube Head to turn the mast.
- As mast tubes extend, they force water out of the weep holes. Keep any personnel or sensitive equipment away from the weep hole direction.
- If the Mast System is mounted in a well, provide adequate drainage. A minimum of four 1 inch (25.4 mm) drain holes (one per corner) are recommended.

2.8.2.2 Install the Shelf Bracket (Optional)

To install a Shelf Bracket (if used):

1. Position the Shelf Bracket ensuring the Shelf Bracket is level.
2. Use the Shelf Bracket as a template to drill holes through the support structure.
3. If necessary, use washers or short spacers made of ¼ inch (6.35 mm) pipe to level out any irregularities that exist in the support structure.
4. Secure the Shelf Bracket to the support structure using:
 - (4) Bolts
 - (4) Flat Washers
 - (4) Lock Washers
 - (4) Nyloc Nuts

See Table 2-3 for hardware sizing. Ensure the Shelf Bracket is level in all directions. The mounting hardware must include proper means to resist vibration loosening such as thread-locking compound or locking hardware. Torque all hardware as appropriate for its size and grade.

2.8.2.3 Attach the Base Plate to the Mast

This section describes installing the mast and Base Plate. The exact procedures will vary depending on whether the Mast System uses a Non-Rotatable or Rotatable Base Plate. Follow the appropriate installation instructions for your Mast System.

Non-Rotatable Base Plates

To install a Non-Rotatable Base Plate:

1. If necessary, use a hoist to lift the mast so the bottom of the mast can be accessed.
2. Position the Base Plate against the base of the mast so the mounting holes align. Ensure the countersunk holes are facing away from the mast.
3. Secure the Base Plate to the mast with the (4) ¾-16x1 flathead screws (P/N: 2772) from the Hardware Bag. Apply Loctite® 242/243 (Blue) or equivalent. Torque to 190-240 in.-lb.

Rotatable Base Plates

To install a Rotatable Base Plate:

1. If necessary, use a hoist to lift the mast so the bottom of the mast can be accessed.
2. Back the Locking Screws far enough out of the Base Plate to allow the Base Plate to fit over the end of the mast.
3. Slide the Base Plate over end of the mast.
4. Tighten down the Locking Screws to secure the Base Plate to the mast.

2.8.2.4 Position the Mast

To position the mast:

1. Carefully move the mast into the desired mounting location.
2. Lower the mast the rest of the way to the mounting surface.
3. Carefully move the mast into position ensuring the mast is level. It is necessary to check the mast in two places 90° apart when leveling. Be certain to orient the mast so the operator has a clear view of the hazard labels.

Note: Additional labels are provided with the operator's manual and should be applied where the operator will have a clear view of them while operating the masts.

2.8.2.5 Install the External Support Bracket

To install the External Support Bracket:

1. Determine the desired location for the External Support Bracket. The External Support Bracket must be at least 1 inch (25 mm) above the Drain Hole and at least 1 inch (25 mm) below the Base Tube Collar. Do not cover the Drain Hole. The exact dimensions of the Mast System will vary based on the components included. Refer to Section 2.6 for dimension information.
2. Secure the External Support Bracket around the Base Tube with the hardware from the External Support Bracket Kit. Do not overtighten the External Support Bracket and deform the Base Tube. This will damage the mast. The mounting hardware must include proper means to resist vibration loosening such as thread-locking compound or locking hardware. Torque all hardware as appropriate for its size and grade.

For External Support Bracket

- P/N: 4443601: Torque the $\frac{3}{8}$ -16 bolts to 190-240 in.-lb.
- P/N: 909984: Torque the $\frac{3}{8}$ -16 bolts to 190-240 in.-lb.
- P/N: 4894901: Torque the first five $\frac{3}{8}$ -16 bolts to 200 in.-lb., and final $\frac{3}{8}$ -16 bolt to 20 in.-lb. (Figure 2-21). Only torque the final $\frac{3}{8}$ -16 bolt after torquing the first five bolts.

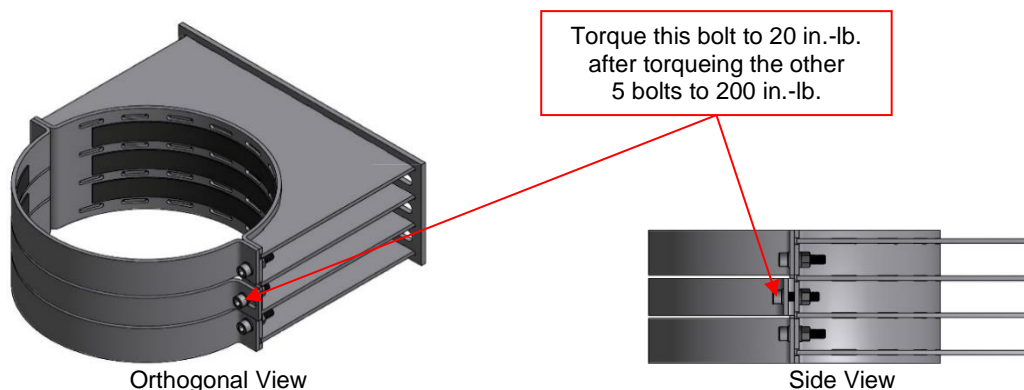

Figure 2-21 External Support Bracket P/N: 4894901 Installation

3. If necessary, use the External Support Bracket as a template to drill holes in the desired support structure. Ensure the Mast System is level in all directions during drilling.
4. Ensure the Mast System is level in all directions. If necessary, spacers may be added between the External Support Bracket and the support structure to keep the correct alignment between the External Support Bracket and the support structure.
5. Secure the External Support Bracket to the support structure with:
 - a. (6) Sets of 7/16 Hardware for External Support Bracket P/N: 4443601
 - b. (6) Sets of 9/16 Hardware for External Support Brackets P/N: 909984 and P/N: 4894901

See Table 2-3 for hardware sizing. The mounting hardware must include a proper means to resist vibration loosening such as thread-locking compound or locking hardware. Torque all hardware as appropriate for its size and grade.

2.8.2.6 Secure the Base Plate to the Mounting Surface

To secure the Base Plate to the mounting surface:

1. If necessary, use the Base Plate as a template to drill holes through the mounting surface.
2. Ensure the Base Plate and mast are level in all directions. It is necessary to check the mast in two places 90° apart when leveling.
3. Secure the Base Plate to the mounting surface with appropriate hardware. To secure the Base Plate, the Hardware Bag contains:
 - a. (4) $\frac{3}{8}$ -16x1- $\frac{1}{2}$ inch Bolts (P/N: 901594)
 - b. (4) Flat Washers (P/N: 2054)
 - c. (4) Lock Washers (P/N: 0801)
 - d. (4) Nuts (P/N: 901593)

Depending on the customer-specific mounting application, other (customer-supplied) hardware may be required. The mounting hardware must include proper means to resist vibration loosening such as thread-locking compound or locking hardware. Torque to 190-240 in.-lb.

2.8.2.7 Install the Turning Handles (Rotatable Mast Systems Only)

Rotatable Base Plate Kits for Standard-Duty and Heavy-Duty masts ship with Turning Handles to assist in rotating the mast. Super-Heavy-Duty masts do not use Turning Handles.

⚠ CAUTION

Equipment Damage – Band Clamp Fasteners! Do not overtighten the Band Clamp fasteners. Overtightening may damage the Base Tube causing the mast tubes to stick.

To secure the Turning Handles:

1. Determine the desired location for the Turning Handles. If feasible, Will-Burt recommends installing above the Drain Hole. Do not cover Drain Hole with the Turning Handles.
2. Secure the Band Clamp Halves together around the mast with
 - (2) ¼-20x1.50 Hex HD Bolts (P/N: 2000)
 - (2) ¼-20 Nyloc Nuts (P/N: 1930)

Tighten the Turning Handle bolts just enough to allow the Turning Handles to turn the mast without slipping. Overtightening the Turning Handle bolts can deform the Base Tube and impede the movement of the next internal section.

For masts with:

- Ø 5.00 Inch Base Tube: Torque to 60 in.-lb. Maximum
- Ø 6.75 Inch Base Tube: Torque to 100 in.-lb. Maximum
- Ø 9.00 Inch Base Tube: Torque to 120 in.-lb. Maximum

The mounting hardware must include proper means to resist vibration loosening such as thread-locking compound or locking hardware.

2.8.2.8 Finalize Installation of Mast System

Once the mast is installed, see Section 2.9 for information on the installation of the following components:

- Drain Kit Installation (Optional) (Section 2.9.1)
- Pneumatic System Installation (Section 2.9.2)
- Magnetic Warning Kit Installation (Section 2.9.3)

2.9 Complete Mast System Installation

The process and images shown in this section describe a possible method of installing the:

- Drain Kit (Optional for external mounting applications)
- Pneumatic System
- Magnetic Warning Kit

Depending on the environment, other methods of installation may work better. Use the best and safest method for your circumstances. Complete mast installation before installing these components. See Figure 2-22 and Figure 2-23 for the general layout of the system.

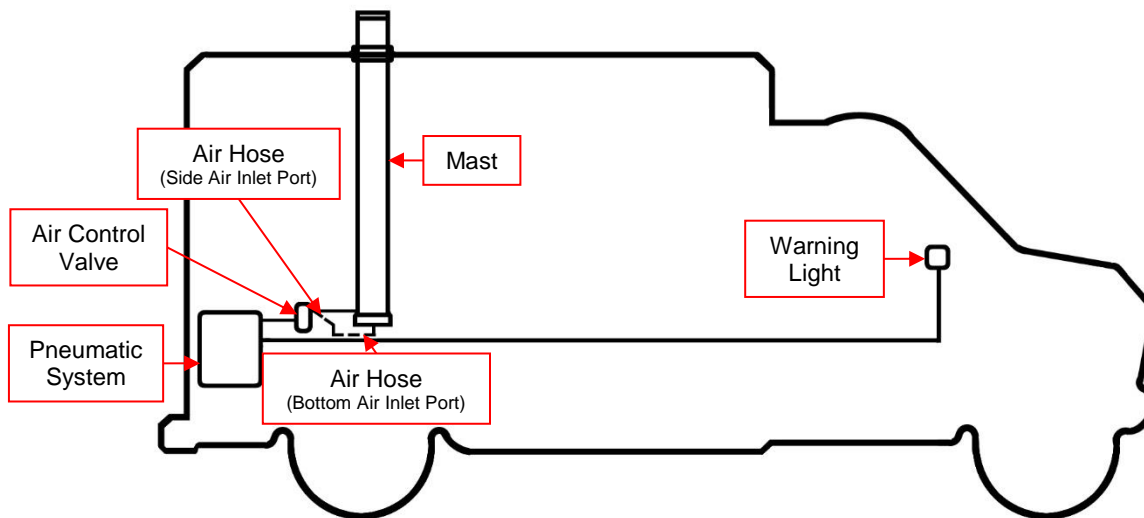

Figure 2-22 Internal Mount General Layout (Not to Scale)

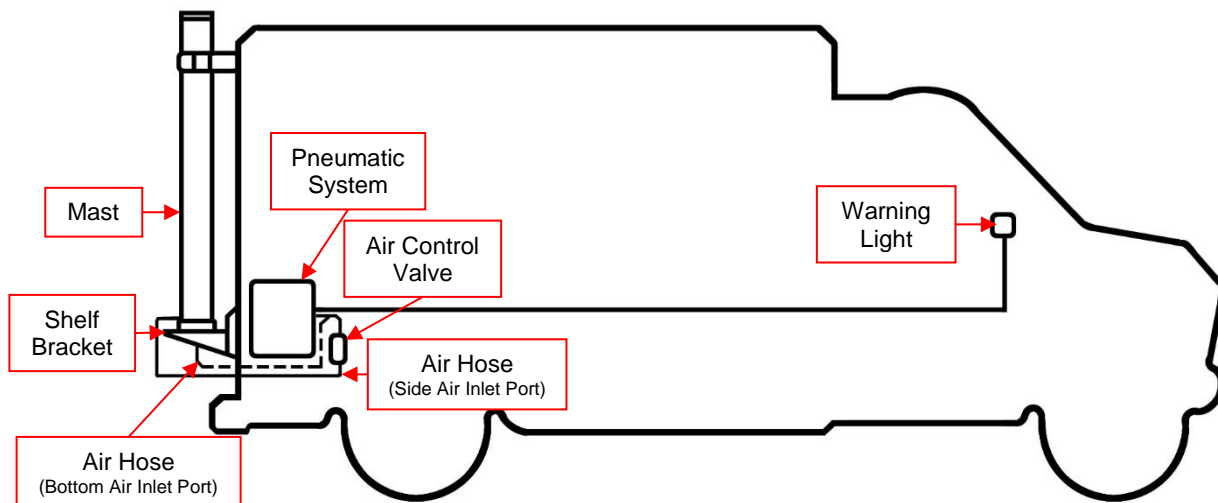

Figure 2-23 External Mount General Layout (Not to Scale)

2.9.1 Drain Kit Installation

Keeping water out of the mast is very important to avoid potential delays in operations and damage to the mast. Water can enter the mast through condensation in the Air Supply, or by rain running down the tubes and entering at the collars. Water that freezes in the mast can cause the mast to work erratically, or not at all.

The Drain Hole on the Base Tube and Weep Holes on the Intermediate Tubes are located to facilitate the drainage of water during periods of extension. The Drain Kit is designed to route water from inside the mast to outside of the vehicle or enclosure. The Drain Kit is intended to protect the interior of a vehicle or other water sensitive area from damage due to water drainage. Drain Kit installation is not required for externally mounted masts.

A Drain Cock, provided in the Hardware Bag, should also be connected to the Air Inlet near the base of the mast and located at the lowest point. The Drain Cock shall be opened when the mast is not in use, or when a locking mast is deployed and depressurized, to empty water that may accumulate inside the Base Tube, particularly after the mast has been exposed to rain. Installation of the Drain Cock is described as part of installation of the Pneumatic System (Section 2.9.2).

⚠ CAUTION

Safety Instruction – Follow Procedures! Failure to follow Drain Kit installation instructions could damage the mast and render the mast inoperable. Read and understand the installation instructions before installing the Drain Kit.

To install the Drain Kit:

1. Be certain the locknut and washer are threaded over the end of the ¼ inch (6.35 mm) Hose Adaptor (Figure 2-24).

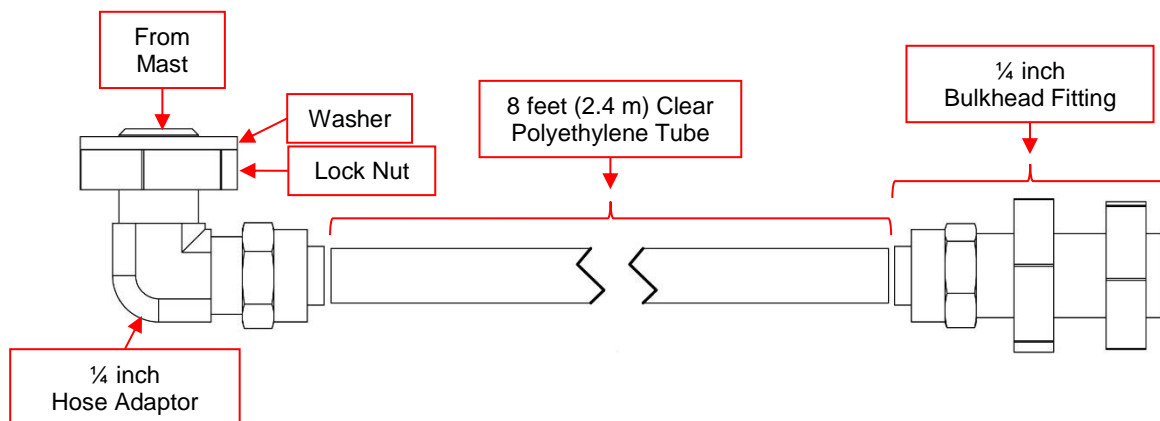

Figure 2-24 Drain Kit (P/N: 902982)

2. Fasten the Hose Adaptor to the Drain Hole (Figure 2-25). Apply PTFE Tape to all threaded joints. Turn the Hose Adaptor in ONLY 1 ½ to 2 times after initial engagement of the threads. Turning further will damage the mast. Tighten the locknut to secure the Hose Adaptor in place. Overtightening could cause the Hose Adaptor to contact the moving Intermediate Tube.

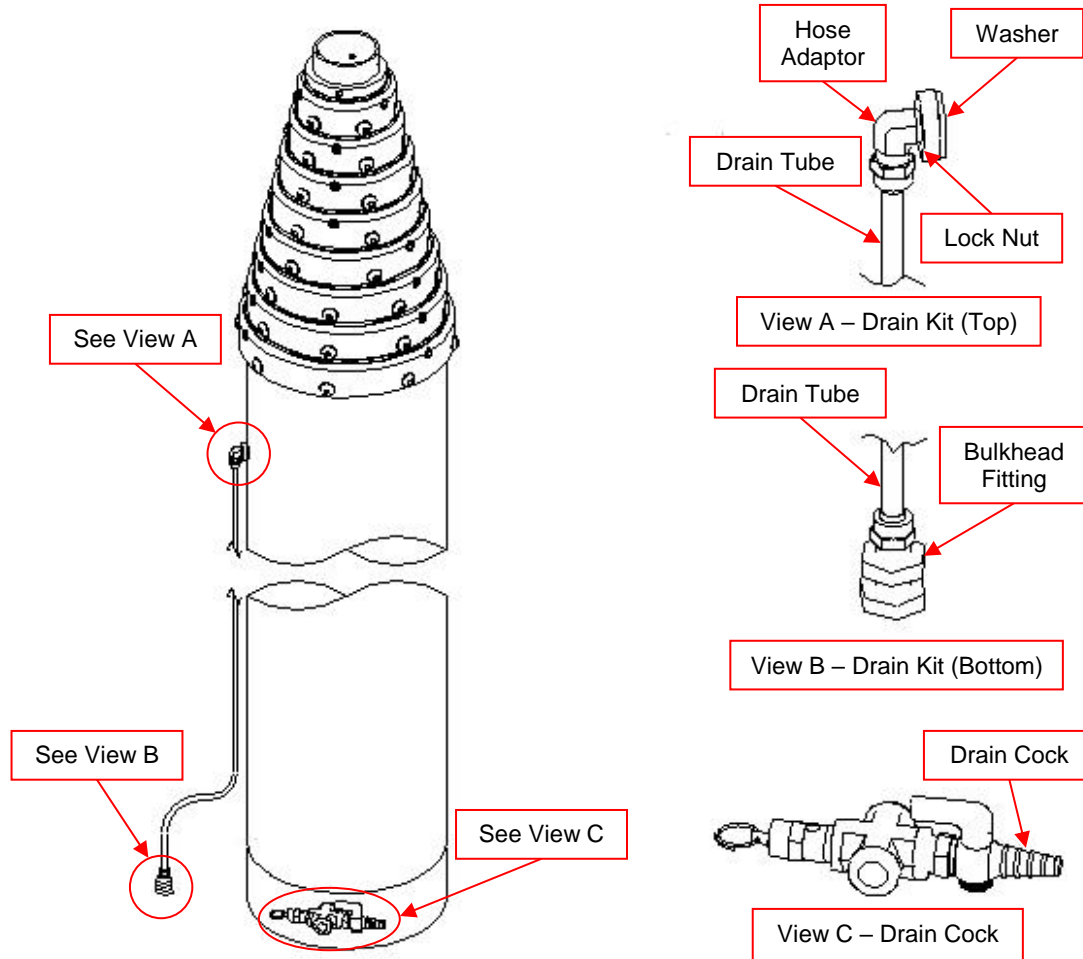

Figure 2-25 Drain Kit Installation

3. Drill a hole in the vehicle or enclosure to route the water outside.
4. Fasten the Bulkhead Fitting (Figure 2-24) to the hole.
5. Attach the Polyethylene Tube to the Hose Adaptor and the Bulkhead Fitting (Figure 2-24). As necessary, the Polyethylene Tube may be cut shorter to fit the customer-specific application. Apply PTFE Tape to all threaded joints.

2.9.2 Pneumatic System Installation

This section describes general principles to keep in mind during installation of the Pneumatic System. Depending on the components of the Mast System and the environment, the exact configuration of the Pneumatic System may vary. Use the best and safest method for your circumstance.

Air to operate the mast may be provided by an Air Compressor or other source of clean dry air. The Pneumatic System should be regulated to not exceed the maximum operating pressure of the mast. The maximum recommended operating pressure is:

- 20 PSIG for Standard-Duty masts
- 35 PSIG for Heavy-Duty and Super-Heavy-Duty masts

2.9.2.1 General Concepts

When installing the Pneumatic System, keep in mind the following:

- **Mounting:** When mounting the Pneumatic System, leave enough space around the unit for ventilation and for access to make initial installation, periodic adjustments, and future maintenance procedures as easy as possible. To reduce vibration in the system, place rubber washers or grommets on the bolts between the mounting pads and the mounting surface. To reduce noise, separate the system from inside the workspace (e.g. the workspace of a vehicle).
- **Electrical:** In accordance with applicable electrical codes, select the proper wiring size, circuit breakers, or fuse size according to the maximum current draw of the Pneumatic System being installed. Refer to the rating information plate on the compressor motor. Be sure to properly ground the compressor motor and all other electrical components. Operation of the compressor may cause interference unless proper isolation or shielding is used. A qualified electrician should perform installation and adjustments.
- **Air Supply:** The Air Supply should have adequate ventilation to provide at least 10 SCFM (283.16 LPM) of clean, dry air at the air intake at all times. The recommended temperature range for inlet air is 32° to 95°F (0° to 35°C), so it works best when located in a heated compartment. The Air Supply should not be operated without the air filters in place.
- **Air Control Valve:** An Air Control Valve should be installed to direct airflow in and out of the mast. The Air Control Valve should be positioned to avoid unintentional operation. Mast movement should stop when the controller or switch is released (hold-to-run type). If the controller is not a hold-to-run type, an emergency stop must be provided. The Air Control Valve should be operable by a person wearing gloves and mounted so it can be used with the mast in full view. The Air Control Valve should be suitable for outdoor use, and marked “Up”, “Down”, or similar.

Note: For some Pneumatic Systems, an Air Control Valve may not be necessary.

- **Drain and Relief Fittings:** A Drain Cock and Safety Valve must be installed to an Air Inlet Port at the base of the mast. The Drain Cock empties water that may have accumulated inside the mast. The Drain Cock shall be opened to drain the mast when not in use, or when a locking mast is extended and depressurized. The Drain Cock should be left open once the mast is fully retracted. The Safety Valve prevents the mast from being over-pressurized.
- **Plumbing:** A length of Air Hose with an ID of $\frac{3}{8}$ inch (9.5 mm), plus additional loose fittings, are supplied with a Will-Burt Pneumatic System if purchased. The Air Hose can be cut to the required length at installation. A Drain Hose should be attached to the exhaust port of the Air Control Valve to drain condensation or oil mist that may exhaust from the mast. Do not remove any hose without first completely exhausting all air from the mast and then disconnecting the power supply.

2.9.2.2 General Procedures

This section describes general procedures and concepts to use when installing the Pneumatic System. Depending on the components and configuration of your system, the exact steps and procedures may vary. Use the best and safest method for your system.

⚠ CAUTION

Safety Instruction – Installation! At all times while using pipe and hose during installation, recognize that:

- Pipe and hose should be routed, mounted and restrained to protect from damage
- Do not use second hand piping for installation
- Do not bend air pipe and hose at a radius less than specified by the manufacturer
- Pipes should be marked to avoid hazards from incorrect connection
- The exhaust should be fitted with a silencer and be directed away from personnel
- When routing piping, install in such a way as to minimize torsion on the joints
- Mounting of air pipe and hose shall be done with tools and in such a way to prevent air pipe and hose from easily disconnecting from the mast

⚠ CAUTION

Safety Instruction – Air Control Valve! Improper positioning and operation of Air Control Valve can result in moderate injury or equipment damage. Air Control Valve must be mounted in a location where the operator has full view of the mast, but does not make contact with the mast during operation. Only use a Hold-To-Run type Air Control Valve or switch. The Air Control Valve shall be normally open when the mast is in transit or not in use.

Figure 2-26 shows the general layout of a pneumatic system. The exact configuration will vary based on the components being used in the specific system.

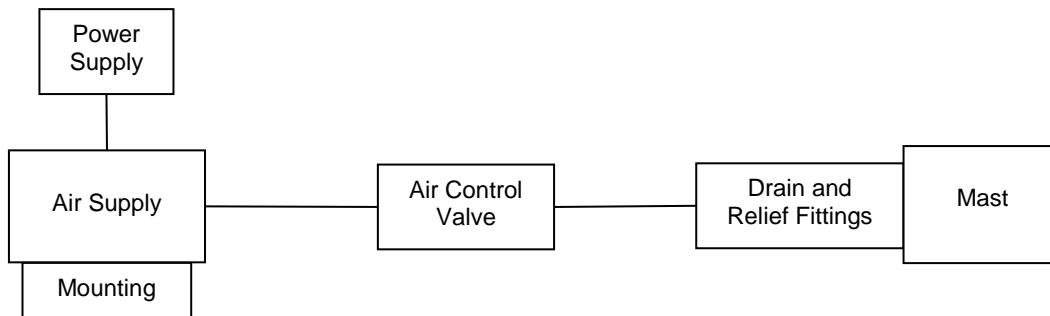

Figure 2-26 General Pneumatic System Layout

To install the Pneumatic System:

1. Locate the Hardware Bag (Section 1.5.1.1). Components from the Hardware Bag will be used during installation of the Pneumatic system.
2. Locate the Air Inlet Port to be used. Depending on the configuration of the mast, there may be more than one Air Inlet Port available. When installing the Pneumatic System only use one Air Inlet Port.
 - To use the Air Inlet Port with the plastic plug:
 - a) Remove the plastic plug. This plug is for thread protection only and the mast should never be pressurized with this plug installed.
 - To use the Air Inlet Port with the stainless steel plug:
 - a) Remove the plastic plug.
 - b) Remove the stainless steel plug. For:
 - Standard-Duty masts, install a customer-supplied ¼ inch (6.35 mm) stainless steel plug in the Air Inlet Port that is not going to be used to attach the Pneumatic System. Pipe thread sealant or PTFE tape should be applied to minimize leakage.
 - Heavy-Duty and Super-Heavy-Duty masts, install the stainless steel plug in the Air Inlet Port that is not going to be used to attach the Pneumatic System. Pipe thread sealant or PTFE tape should be applied to minimize leakage.

Note: The plastic plug is for thread protection only. The mast should never be pressurized with the plastic plug installed. Ensure any unused Air Inlet Port is plugged with a stainless steel plug.

- Attach the Brass Cross to the desired Air Inlet Port with a Close Nipple (Figure 2-27). Heavy-Duty and Super-Heavy-Duty masts will also require a Bushing. Apply PTFE Tape to all threaded joints. If necessary, Air Hose may be used to connect between the Air Inlet Port and the Brass Cross, however, the Brass Cross should be installed as close to the mast as possible to ensure proper drainage.

Note: If desired, Swivel Fittings (P/N: 900481 and P/N: 900483) are available for use with the Bottom Air Inlet Port.

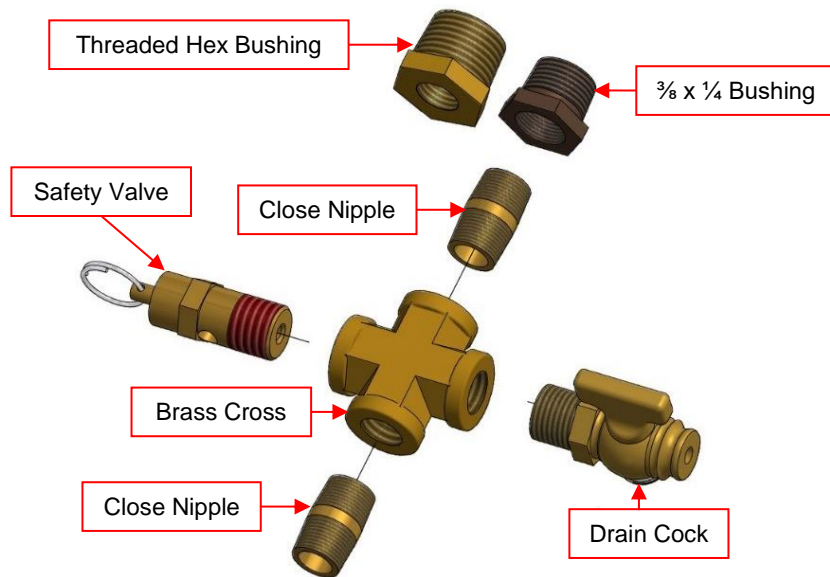

Figure 2-27 Pneumatic System Installation

- Attach the Safety Valve to the Brass Cross. Apply PTFE Tape to all threaded joints.
- Attach the Drain Cock to the Brass Cross. Apply PTFE Tape to all threaded joints.

Note: The Drain Cock should be located at the lowest point. When the mast is not in use, or when a locking mast is deployed and depressurized, the Drain Cock shall be left open.

- If necessary, mount the Air Supply to the mounting structure with appropriate hardware. The mounting hardware must include proper means to resist vibration loosening such as thread-locking compound or locking hardware. Torque all hardware as appropriate for its size and grade.

Note: The Air Supply should not be operated without air filters in place.

- Connect the Air Supply to the Brass Cross with Air Hose and a Close Nipple. Apply PTFE Tape to all threaded joints.

Note: Depending on the Air Supply used, it may be necessary to install an Air Control Valve in-line between the Air Supply and the Brass Cross.

- If necessary, connect the Power Supply to the Air Supply. Be certain to observe any local codes or regulations.

2.9.3 Magnetic Warning Kit Installation

When installing the Mast System on a vehicle, the Magnetic Warning Kit shall be installed to provide a warning against moving the vehicle while the mast is partially or fully extended. When correctly installed, flashing lights will indicate partial or full extension of the mast when the ignition is on. When the mast is properly nested, or the ignition is off, the lights will cease to illuminate. The lead to the positive battery terminal should be connected to the ignition switch so the lights will only illuminate when the mast is extended and the ignition is on. The operator should always visually confirm that the mast is entirely retracted before moving the vehicle. Be certain to observe any local codes or regulations.

To install the Magnetic Warning Kit:

1. Tie one end of a piece of string to the top of the Magnet (Figure 2-28).

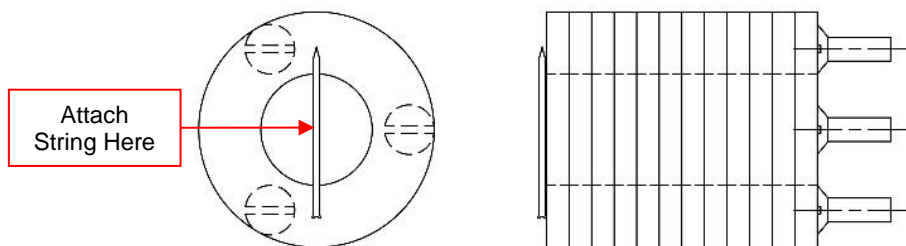

Figure 2-28 Magnet

2. Carefully lower the Magnet into the top of the Top Tube.
3. Using the string, lower the Magnet to the bottom. It is important that the Magnet is resting on the bottom end of the Top Tube. Cut off the excess string.
4. Assemble the Magnetic Switch Assembly and the stainless steel band.
5. Attach the Magnetic Switch Assembly loosely around the Base Tube approximately 6 to 20 inches (15 to 51 cm) above the Base Plate (Figure 2-29). The Magnetic Switch Assembly can be located anywhere around the perimeter of the Base Tube.

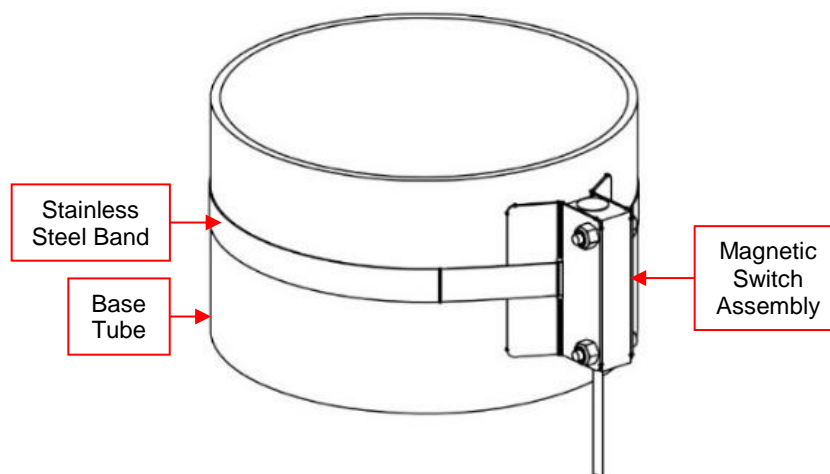

Figure 2-29 Magnetic Switch Assembly Attached to Base Tube

6. For applications with a Relay, mount the Relay. Do not mount the Relay any closer than 6 inches (15 cm) from the Magnetic Switch Assembly that is clamped to the mast. When energized, the Relay produces an electromagnetic field that could affect the performance of the Reed Switch in the Magnetic Switch Assembly if the Relay is mounted too close.
7. Mount the Flasher keeping in mind that wire will eventually need to be routed from the Magnetic Switch Assembly to the flasher. In applications with a Relay, the wire will be routed from the Magnetic Switch Assembly to the Relay and then to the Flasher.
8. Mount the Lights keeping in mind that wire will eventually need to be routed from the Flasher to the Lights. One flashing Light should be mounted to the vehicle dash in full view of the driver.
9. For mast models:
 - a. 5-20, 6-27, 7-34, 8-30, 6-25, and 7-30: Use 16 AWG stranded wire (customer-supplied) to connect the flasher and lights to the wires exiting the Magnetic Switch Assembly (Figure 2-30).

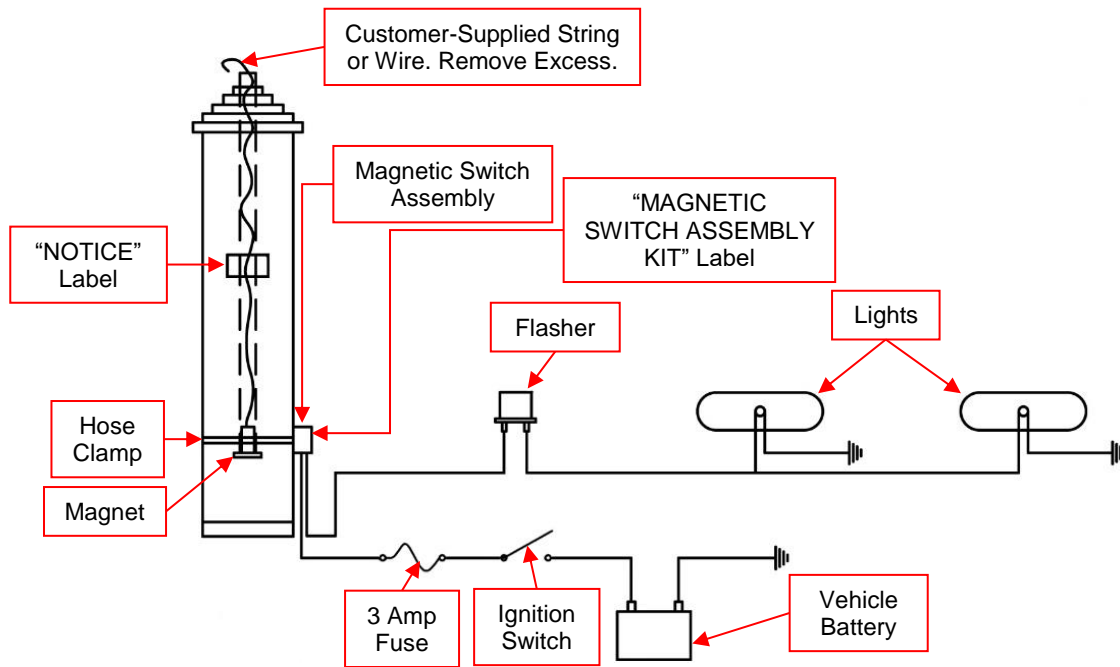

Figure 2-30 Wire the Magnetic Switch Assembly Kit

- b. 10-38, 12-48, 7-42, 8.5-48, 9-50, 8.5-52, 9.5-56, 9-58, 10-60, 9-50, 10.3-60, and 10.8-76: Use 16 AWG stranded wire (customer-supplied) to connect the flasher, lights, and relay to the wires exiting the Magnetic Switch Assembly (Figure 2-31 and Figure 2-32).

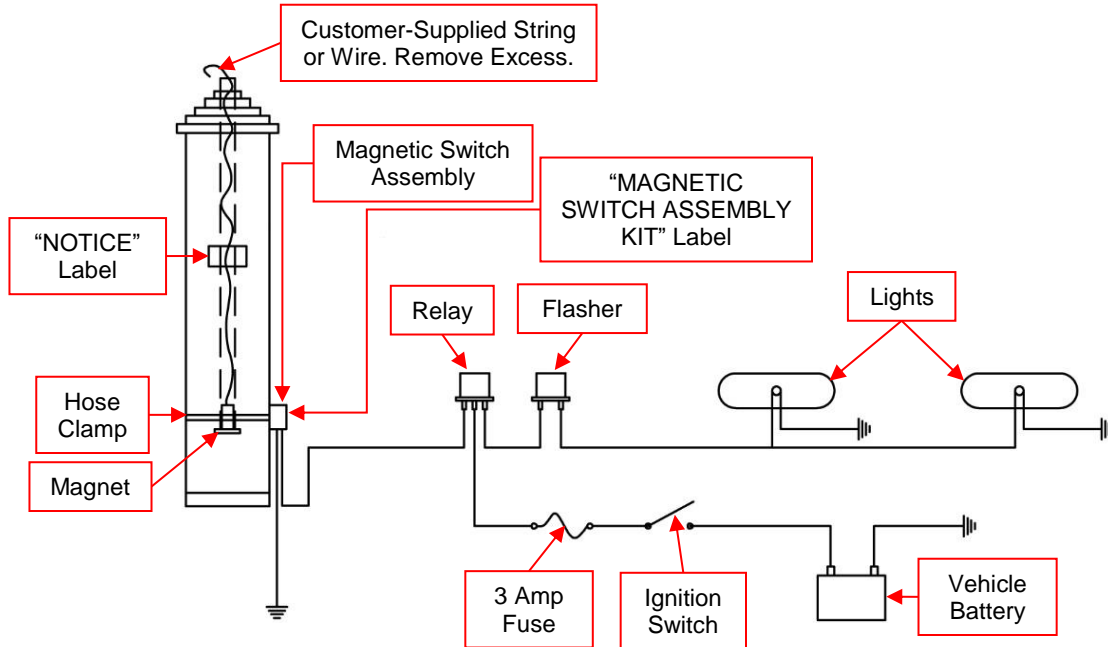

Figure 2-31 Wire the Magnetic Switch Assembly Kit

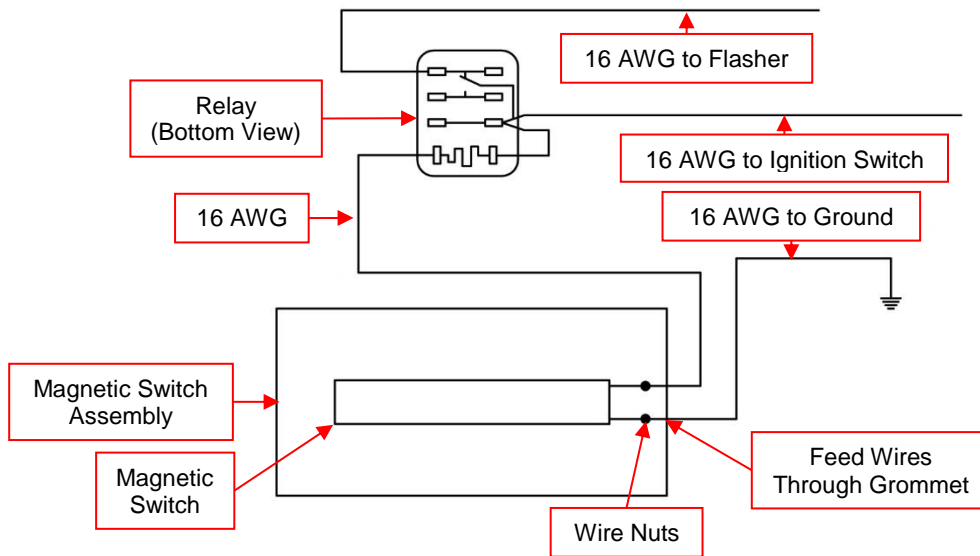

Figure 2-32 Relay and Magnetic Switch Assembly Wiring

10. Use customer-supplied 16 AWG stranded wire to connect the Magnetic Switch Assembly to vehicle power through the ignition.
11. Ensure:
 - c. The mast is fully nested
 - d. The Flasher and Lights are installed and connected to the ignition through the battery
 - e. The ignition is on

Note: The Light should be flashing unless the switch is in contact with the magnet assembly.

12. Slide the Magnetic Switch Assembly up and down the lower two feet (60 cm) of the Base Tube to locate the Magnet Assembly inside the tube. When the Magnet Assembly is located, the Lights will stop flashing. The vertical sensing range should be about 1 to 3 inches (2.5 to 7.5 cm).
13. Tighten the band to clamp the Switch Assembly within the sensing range ensuring it is not lower than 1 inch (2.5 cm) above the lower limit of the sensing range. The 1 inch (2.5 cm) allows for seasonal variations in the Top Tube position.
14. Attach the "NOTICE" label in a visible area on the Base Tube (Figure 2-31).
15. Attach the "MAGNETIC EXTENSION WARNING KIT" label to the Magnetic Switch Assembly (Figure 2-31).
16. Extend the mast 1 to 2 feet (31 to 61 cm) and then nest the mast. Repeat several times to test the Magnetic Warning Kit. For information on operating the Mast System, see Section 3.3.

2.10 Additional Accessory Installation

Depending on the configuration of the Mast System, optional components selected, or the installation environment, additional accessories such as Cable Guides, Nycoil® Baskets, and positioners may need to be installed. Install any additional accessories as appropriate. Contact The Will-Burt Company with any questions before performing any installation procedures.

2.11 Test the Installation

Follow all precautions while testing the Mast System installation.

To test the installation:

1. Review the Pre-Operation Check.
2. Prepare the Mast System for operation.
3. Extend the mast.
4. For rotatable applications, rotate the mast.
5. Lower the mast.

Note: The Drain Cock shall remain open to drain water when the mast is not in use. The Drain Cock shall be opened while a locking mast is deployed and depressurized to drain water. It is not uncommon to have mast grease exit the drain or exhaust valve on initial mast use.

See Section 3 for additional details on these procedures.

2.12 Install Payload

WARNING

Safety Instruction – Mounting Instructions! Before operation, be certain the mounting structure is capable of resisting forces generated from all loading and environmental conditions including, but not limited to payload size and weight, sail size, and wind and ice loading. The mounting hardware must include proper means to resist vibration loosening such as thread-locking compound or locking hardware. Mounting the payload into a structure unable to resist the forces generated from the customer-specific loading scenario could result in death or serious injury, and could damage the mast and mounting structure.

CAUTION

Safety Instruction – Mast Access! The operator must provide safe means to access the top of the mast during installation and removal of the payload.

The exact installation procedures for payload will vary based on the customer-specific payload and Payload Platform or Stub Adaptor being used. For optimal performance, center the payload as best as possible. If the payload must be offset, offset the payload in-line with the keys. Contact The Will-Burt Company with any questions before performing any installation procedures.

In general, to install the payload:

1. Ensure the Air Supply is disconnected and the Drain Cock is opened while installing the payload to eliminate the possibility of inadvertent mast extension.

2. If necessary, remove the Mast Top Cover.

Note: If the payload is removed, the Mast Top Cover should be put back on.

3. Carefully move the payload into position.
4. Properly secure the payload to the mast. The mounting hardware must include proper means to resist vibration loosening such as thread-locking compound or locking hardware. Torque all hardware as appropriate for its size and grade.

Note: If securing a payload part-way along a mast tube, be sure not to overtighten the tube, or damage to the mast could occur. Intermediate Tubes Clamps are available to assist in attaching payloads to the Intermediate Tubes. See www.willburt.com for additional information.

(This page is intentionally left blank.)

Section 3 Operation

This section describes the operation of the Mast System. Use care to understand and follow all precautions while operating.

3.1 Pre-Operation Check

Before operating the Mast System, ensure:

- All operators read and understand the entire operation procedure and are properly trained.
- The Mast System is undamaged. If damage is apparent, do not use the Mast System, and have it serviced prior to use.
- All electrical cables are undamaged and properly terminated.
- The area is free of power lines or other overhead obstructions. The Mast System location should be no closer than a horizontal distance equal to the extended height of the mast away from power lines.
- Any objects that might obstruct motion of the Mast System, cause binding, or hinder Mast System function are removed.
- The Mast System and payload are properly installed.
- When using a vehicle, the vehicle is not moving and is on level terrain.
- The mast is on level terrain. The mast can be operated on terrain having a slope up to 5° of vertical for Standard-Duty masts and Heavy-Duty masts with extended heights up to 60 feet, and within 3° of vertical for Heavy-Duty masts with extended heights greater than 60 feet and Super-Heavy-Duty masts
- Any transit tie-downs have been removed.
- The Mast System area is free of personnel.
- The operator has full view of the Mast System during use.
- Ensure the following precautions are understood and followed:

⚠ WARNING

Burst Hazard! Over-pressurizing mast will trip safety valve and could result in death or serious injury. Do not exceed maximum operating pressure of 35 psi (241 kPa) for Heavy-Duty and Super-Heavy-Duty masts. Do not exceed maximum operating pressure of 20 psi (138 kPa) for Standard-Duty masts. Keep personnel clear of safety valve exhaust direction.

⚠ WARNING

Pinch Point Hazard! Moving parts can crush and cut resulting in death or serious injury. Keep clear of moving parts while operating mast.

⚠ WARNING

Mast Extension Hazard! Extending mast into obstructions could result in death or serious injury and could render the mast inoperable and partially extended. Before applying power and operating the mast, be certain there is sufficient clearance above and to all sides of the expected location of the fully extended mast and payload. Keep all persons clear of mast and mast extension. Do not lean directly over the mast.

⚠ WARNING

Relocation Hazard! Relocating the mast during operation or after extension could result in death or serious injury. Do not relocate the mast during operation or while extended. This applies especially to masts mounted to vehicles. Operate the mast only if the vehicle is stationary and the vehicle engine is off. Do not install mast on a vehicle without installing the Magnetic Warning Kit.

⚠ WARNING

Safety Instruction – Operation! At all times prior to mast operation, ensure:

- The mast area is free of personnel and mechanical obstruction
- All electrical cables are undamaged and properly terminated
- The operator has full view of the mast during use
- Any transit tie-downs on the payload have been removed
- The vehicle is not moving
- The Magnetic Warning Kit is installed on a vehicle
- The area above the mast is free of mechanical obstructions and electrical power lines
- The mast Base Tube angle is within 5° of vertical for Standard-Duty masts and Heavy-Duty masts with extended heights up to 60 feet, and within 3° of vertical for Heavy-Duty masts with extended heights greater than 60 feet and Super-Heavy-Duty masts

⚠ WARNING

Lifting Hazard – Intended Use! The mast is intended to lift a specific payload for lighting, surveillance or communication use only. Any other use without written consent is prohibited and could cause death or serious injury. Do not use mast to lift personnel. Do not exceed specified payload capacity. Large payload wind sail areas can reduce payload capacity. Consult Will-Burt engineering.

⚠ WARNING

Crush Hazard – Mast Failure! Death or serious injury could result if mast fails suddenly. Do not stand directly beneath the mast or its payload. Be certain payload is properly installed and secured.

⚠ WARNING

Safety Instruction – Potential Air Contaminants! If internally mounted, air from the mast will discharge into the vehicle while the Drain Cock is open.

⚠ WARNING

Impact Hazard! The mast should operate smoothly during extension and retraction. If erratic mast motion is observed during extension or retraction that results in impact loading between the tube and the tube collar (mechanical travel stop), cease use of the mast and contact Will-Burt service. Operating a mast with erratic mast tube motion over time could result in mast separation and could cause damage to the mast or result in death or serious injury.

⚠ WARNING

Safety Instruction – Operation! For outdoor use only. Do not use in areas that have been classified as hazardous as defined in Article 500 of the National Electric Code.

⚠ WARNING

Safety Instruction – Keep Clear! Keep personnel clear of the Mast System during operation.

⚠ WARNING

Safety Instruction – Rapid Release of Air Pressure! If the Mast System air pressure is not fully discharged prior to removing the Air Hoses, a rapid release of air pressure will occur causing a need for hearing and eye protection.

⚠ CAUTION

Equipment Damage – Obstruction! Check for and remove any objects that might obstruct motion, cause binding, or hinder function of the Mast System. Hitting obstructions will cause damage to the mast.

⚠ CAUTION

Equipment Damage – Deviation! Deviation from standard operating conditions and procedures could cause system failure.

⚠ CAUTION

Entanglement Hazard! Tangled cables can cause equipment damage. Ensure control cables, Guy Lines, and Trip Lines are not tangled and are free to pay out as mast is extended.

⚠ CAUTION

Frozen Water Hazard! Water freezing inside mast or air fittings may render mast inoperable and cause major equipment damage. Open Drain Cock, when mast is not in operation. The Drain Cock shall be installed at the lowest position in the Pneumatic System. Cover locking masts when not in use. Non-locking masts stored outdoors should be covered if possible. Will-Burt P/N: 902989 is available from Will-Burt.

⚠ CAUTION

Safety Instruction – Guy Anchors! When using Guy Lines, the installer shall verify the Guy Anchor point strength is adequate to support the Guy Line forces.

3.2 Operation Equipment

Table 3-1 lists recommended equipment for operation.

Table 3-1 Equipment Recommended for Operation

Recommended Equipment*			
Personal Protective			
	Safety Glasses	Work Gloves	Nitrile or Vinyl Gloves
	Hearing Protection	Hard Hat or Helmet	Safety Shoes
* Depending on the local, regional, and national standards and codes of practice, and the environment, additional personal protective equipment may be necessary.			

3.3 Mast Operation

This section describes operation of the Mast System. The exact operating procedures will vary based on the configuration of your Mast System. Follow the appropriate operation procedures for your Mast System.

Operation of the Mast System is described as follows:

- Prepare the Mast System for Operation (Section 3.3.1)
- Non-Locking Mast Operation (Section 3.3.2)
- Locking Mast with T-Handle Yoke Assembly Operation (Section 3.3.3)
- Locking Mast with Trip Lines Operation (Section 3.3.4)

Note, in general:

When extending masts with both T-Handle Yoke Assemblies and Trip Lines:

1. Extend the mast sections with T-Handle Yoke Assemblies according to Section 3.3.3.
2. Properly guy the extended mast sections according to the Guy Kit.
3. Extend the mast sections with Trip Lines according to Section 3.3.4.

When lowering masts with both T-Handle Yoke Assemblies and Trip Lines:

1. Lower the mast sections with Trip Lines according to Section 3.3.4.
2. Properly decrease the tension for the Guy Lines for the mast sections with T-Handle Yoke Assemblies.
3. Lower the mast sections with T-Handle Yoke Assemblies according to Section 3.3.3.

3.3.1 Prepare the Mast System for Operation

To prepare the Mast System for operation:

- Ensure the Mast System is stationary on level, stable ground. The Base Tube shall be within 5° of vertical for Standard-Duty masts and Heavy-Duty masts with heights up to 60 feet, and within 3° of vertical for Heavy-Duty masts with heights greater than 60 feet and Super-Heavy-Duty masts.
- Perform the Pre-Operation Check (Section 3.1)
- Prepare the Pneumatic System for operation. As part of this:
 - Close the Drain Cock
 - Connect the Air Supply to the mast
 - If necessary, connect power to the Air Supply
- If necessary, secure any cables to the mast
- If necessary, secure the payload to the mast (Section 2.12)
- Ensure the proper personnel are available to operate the mast. For applications using Guy Lines, a minimum of:
 - (2) People are necessary to operate the Guy Lines (Guy Lines must be operated opposite of each other)
 - (1) Person must observe the mast to ensure it is standing straight and not leaning in any direction
 - (1) Person must operate the Pneumatic System

It may be possible for the person observing the mast to also operate the Pneumatic System.

- Ensure the mast is only being operated in safe wind speeds. Deployment and retraction wind speeds are payload dependent, however the mast can typically be deployed and retracted in winds speeds up to 25 mph (40 km/h) assuming:
 - 12 Inch Maximum Offset Payload from Mast Centerline
 - Mast deployment angle is:
 - 5° of vertical for Standard-Duty and Heavy-Duty masts with extended heights ≤ 60 feet
 - 3° of vertical for Heavy-Duty masts with extended heights > 60 feet
 - 3° for all Super-Heavy-Duty masts
 - Operating Temperature -20°C to 60°C (-4°F to 140°F)

Check with Will-Burt Engineering for additional wind information for customer-specific loading scenarios.

3.3.2 Non-Locking Mast Operation

The following are detailed steps of operation of the non-locking mast.

3.3.2.1 Extend the Mast

This section describes extending the mast. Depending on the system configuration, it is possible to extend the mast with either powered or manual operation. When manually operating the mast, ensure all electrical circuits are de-energized and properly tagged to prevent injury during operation.

As mast tubes extend, they force water out of the weep holes. Keep any personnel or sensitive equipment away from the weep hole direction while extending the mast.

To extend the mast:

1. Prepare the Mast System for Operation (Section 3.3.1).
2. If necessary, secure the payload to the mast (Section 2.12).
3. Ensure the payload will have enough clearance as the mast is extended.
4. Pressurize the mast. Maintain visual contact throughout extension to avoid overhead obstructions and cable entanglements. Do not exceed the maximum recommended operating pressure of the mast at any time. The maximum recommended operating pressure is:
 - 20 PSIG for Standard-Duty masts
 - 35 PSIG for Heavy-Duty and Super-Heavy-Duty masts

Stop pressurizing the mast when the desired height is achieved. The mast must remain pressurized to maintain its height. Note that partially extended, non-locking masts may move due to internal air temperature changes.

3.3.2.2 Rotate the Mast (Rotatable Mast Applications Only)

Applications using a Rotatable Base Plate can be rotated.

To rotate the mast:

1. Loosen the Locking Screws (Figure 3-1) on the Base Plate approximately one turn.

Note: The appearance of the rotating Base Plate may vary based on the Mast System configuration.

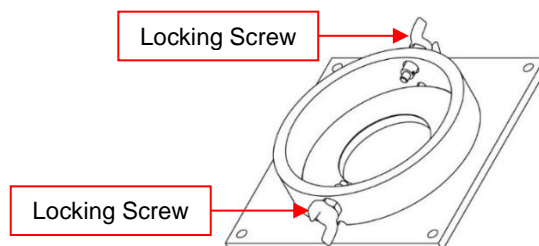

Figure 3-1 Locking Screws (P/N: 5074601 Shown)

- For Standard and Heavy-Duty masts, use the Turning Handles to rotate the mast as desired. Maintain visual contact throughout rotation to avoid obstructions and to ensure tubing and cables are not tangled or damaged during rotation.

For Super-Heavy-Duty masts, insert a customer-supplied rod into one of the four holes in the Tube Head to provide leverage to turn the mast (Figure 3-2). As necessary, the rod can be moved between holes.

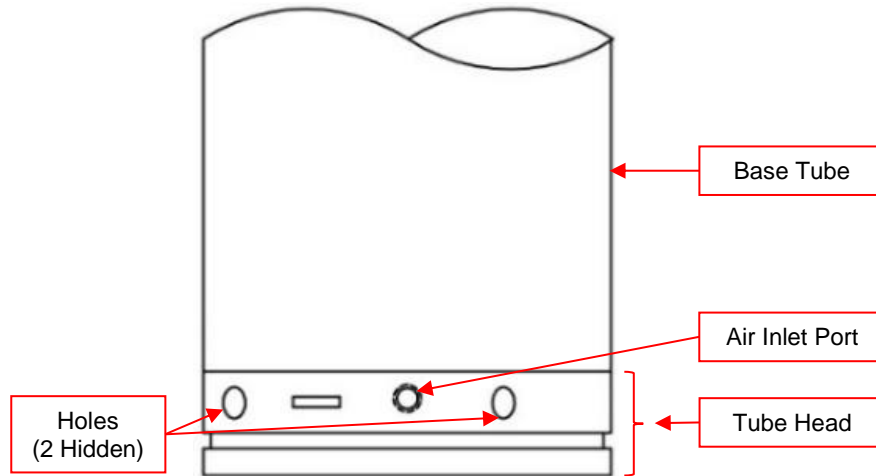

Figure 3-2 Bottom of Rotatable Super-Heavy-Duty Mast (P/N: 909426 Shown)

- Re-tighten the locking screws to hold the position. Lock the mast in place by tightening the Locking Screws on the Base Plate at all times unless the mast is to be rotated.

3.3.2.3 Lower the Mast

⚠ WARNING

Pinch Point Hazard! Moving parts can crush and cut resulting in death or serious injury. Keep clear of moving parts while operating mast.

⚠ CAUTION

Frozen Water Hazard! Water freezing inside mast or air fittings may render mast inoperable and cause major equipment damage. Open Drain Cock, when mast is not in operation. The Drain Cock shall be installed at the lowest position in the Pneumatic System. Cover locking masts when not in use. Non-locking masts stored outdoors should be covered if possible. Will-Burt P/N: 902989 is available from Will-Burt.

To lower the mast:

- Ensure the payload will have enough clearance when nested. For applications using a Rotatable Base Plate, if necessary, rotate the mast (Section 3.3.2.2) so the payload will have the necessary clearance to nest.
- Exhaust air from the mast. The mast will retract by its own weight, and the weight of the payload. Maintain visual contact with the mast during retraction to avoid cable and/or payload hang-ups.

3. Periodically open the Drain Cock when exhausting the mast to drain off any accumulated water.
4. Disconnect the Air Supply while the mast is not in use to eliminate the possibility of inadvertent mast extension.
5. Open the Drain Cock when the mast is not in use.

Note: The operator should always visually confirm the mast is entirely retracted before moving the vehicle. For further information on transporting the Mast System, see Section 4.

3.3.3 Locking Mast with T-Handle Yoke Assemblies Operation

The following are detailed steps of operation of the locking mast with T-Handle Yoke Assemblies.

3.3.3.1 Extend the Mast

This section describes extending the mast. Depending on the system configuration, it is possible to extend the mast with either powered or manual operation. When manually operating the mast, ensure all electrical circuits are de-energized and properly tagged to prevent injury during operation.

As mast tubes extend, they force water out of the weep holes. Keep any personnel or sensitive equipment away from the weep hole direction while extending the mast.

To extend the mast:

1. Prepare the Mast System for Operation (Section 3.3.1).
2. Remove the Mast Top Cover.
3. Secure the payload to the mast (Section 2.12).

- If Guy Lines are used, attach the Guy Lines to the color-coded lugs on the collars. If Cable Guides are present, ensure the Guy Lines are outside the Cable Guides for the collars below where they attach (Figure 3-3).

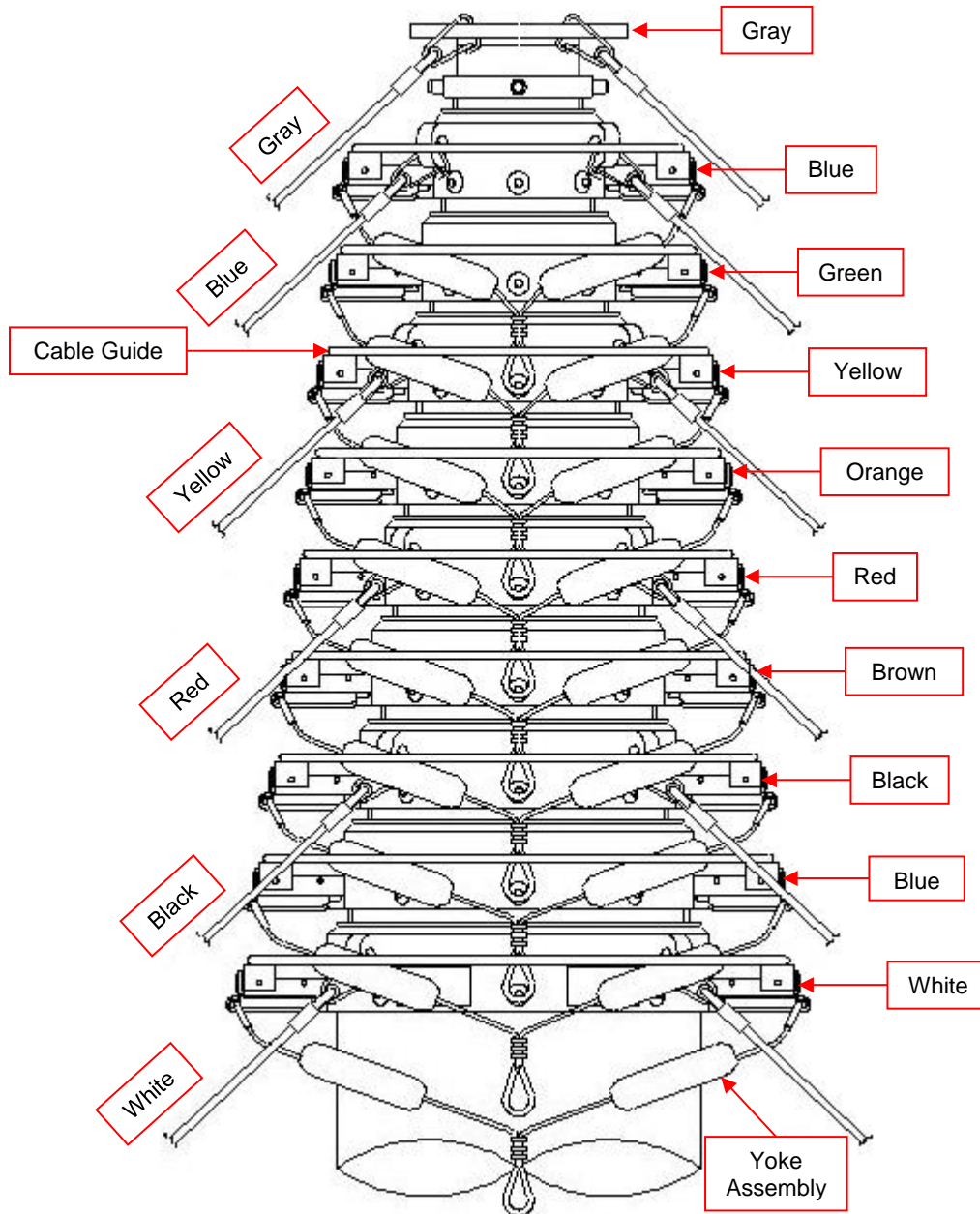

Figure 3-3 Sample of Guy Line Attachment on a Mast with Cable Guides (Mast with Trip Lines Shown)

5. Prior to extending the mast, Will-Burt recommends laying out any Guy Lines so they do not become tangled during extension (Figure 3-4).

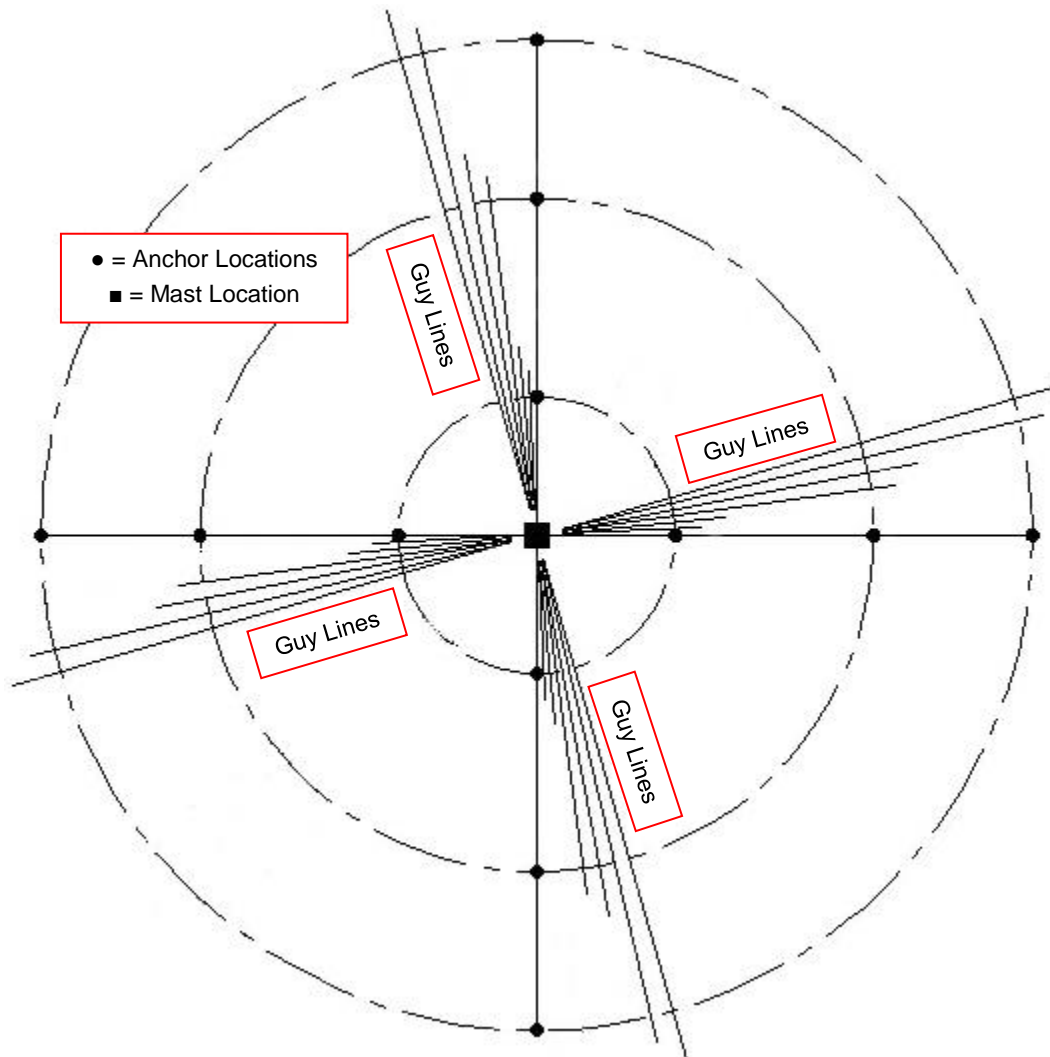

Figure 3-4 Sample of Laying Out Guy Lines (Mast with 4 Way 5 Level Guying Shown)

6. Ensure the payload will have enough clearance as the mast is extended.
7. With the mast depressurized, lightly pull down the top T-Handle attached to the smallest collar. Do not pull hard, tug, or jerk on the T-Handle, or damage to the mast locks could occur. Typically, only approximately 5 to 10 lb. (2.3 to 4.5 kg) of pressure will be necessary.

Note: The mast tubes of a mast with T-Handle Yoke Assemblies are extended from smallest to largest mast tube.

8. Pressurize the mast while continuing to hold down the T-Handle. While pressurizing the mast, you should feel the locks unlatch without needing to apply substantial pressure. Observe the Latch Levers (Figure 3-5) to confirm they have unlatched. When unlocked, they should both be pointing down at about a 45° angle from the collar ears. It is possible for the Latch Levers to be at a slight angle and still be latched.

Continue holding down the T-Handle until the mast tube is fully extended.

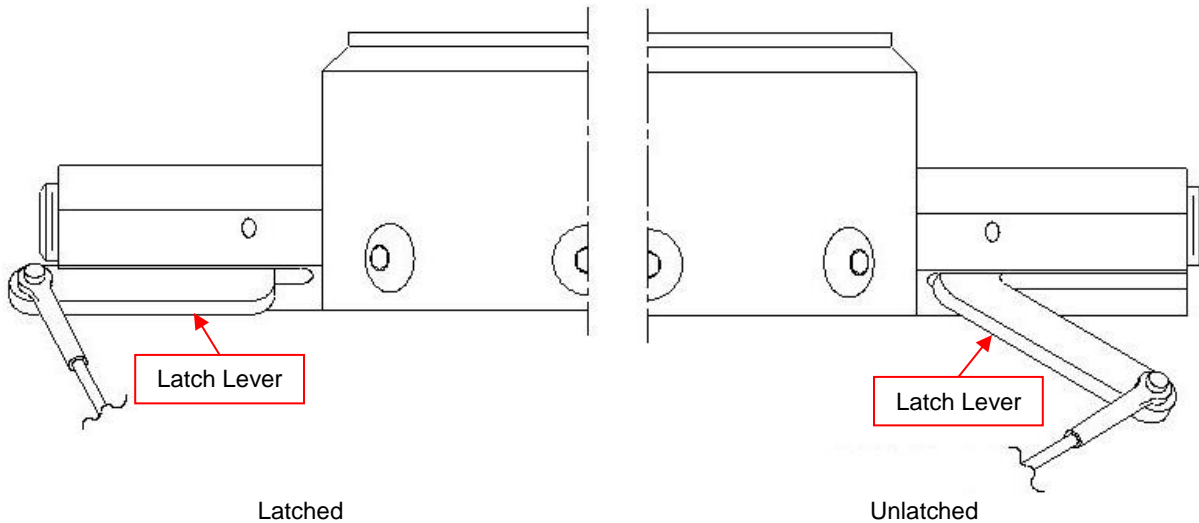

Figure 3-5 Latch Lever Positions

Maintain visual contact throughout extension to avoid overhead obstructions and to ensure none of the cables become tangled or snag on anything. Do not over-pressurize the mast. Over-pressurizing the mast could cause locks to jam. Do not exceed the maximum recommended operating pressure of the mast at any time. The maximum recommended operating pressure is:

- 20 PSIG for Standard-Duty masts
 - 35 PSIG for Heavy-Duty and Super-Heavy-Duty masts
9. When the mast tube is fully extended, release the T-Handle and stop pressurizing the mast. The spring-loaded Latch Pins will lock this tube in the extended position.
 10. Exhaust all air from the mast to confirm the mast tube is locked. If the tube comes down, repeat steps 7 to 10.
 11. Repeat the same procedure for each subsequent mast tube going from smallest to largest. Stop extending the mast when the desired height is achieved. Any combination of tubes can be extended if the full height of the mast is not required.

Note: When leaving a mast partially extended in potentially freezing conditions, follow the *Weatherizing Instructions for Pneumatic Masts* (TP-4744301).

12. Exhaust all air.

13. Applications using a Rotatable Base Plate can be rotated. Depending on the Mast System configuration, it may be necessary to adjust additional components such as Guy Lines or Trip Lines when rotating the mast.

To rotate the mast:

- a. Loosen the Locking Screws (Figure 3-6) on the Base Plate approximately one turn.

Note: The appearance of the rotating Base Plate may vary based on the Mast System configuration.

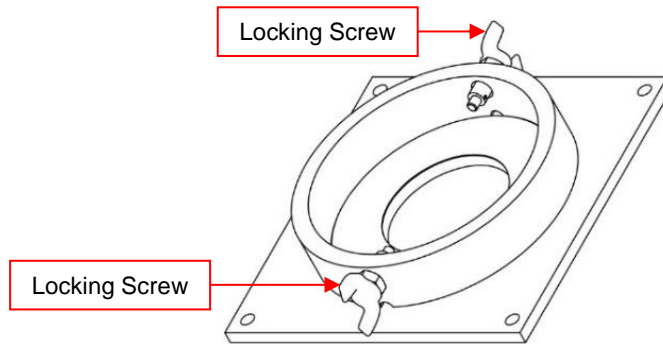

Figure 3-6 Locking Screws (P/N: 5074601 Shown)

- b. For Standard and Heavy-Duty masts, use the Turning Handles to rotate the mast as desired. Maintain visual contact throughout rotation to avoid obstructions and to ensure tubing and cables are not tangled or damaged during rotation.

For Super-Heavy-Duty masts, insert a customer-supplied rod into one of the four holes in the Tube Head to provide leverage to turn the mast (Figure 3-7). As necessary, the rod can be moved between holes.

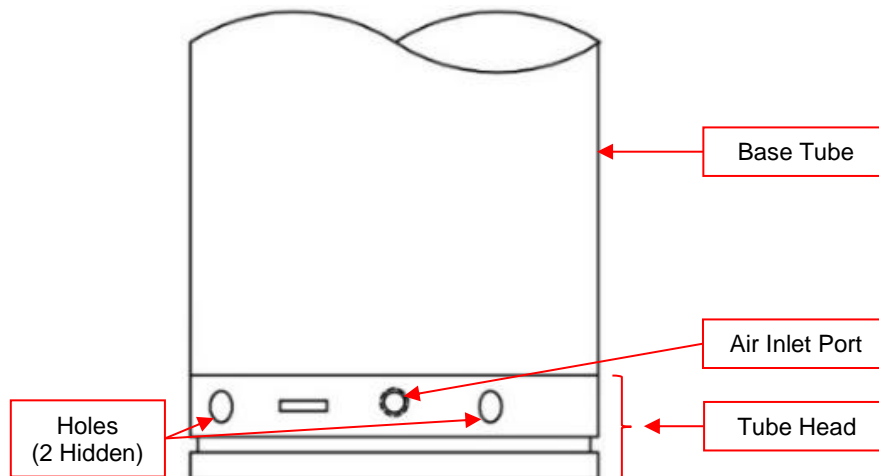

Figure 3-7 Bottom of Rotatable Super-Heavy-Duty Mast (P/N: 909426 Shown)

- c. Re-tighten the Locking Screws to hold the position. Lock the mast in place by tightening the Locking Screws on the Base Plate at all times unless the mast is being rotated.

14. If Guy Lines are used, properly secure and tension the Guy Lines immediately after raising the mast. The installer shall verify the Guy Anchor point strength is adequate to support the Guy Line forces. All Guy Lines should be equally tensioned. Beginning at two locations opposite each other, gradually tension each Guy Line. Vertical alignment of the mast is accomplished by observing the mast perpendicularly to the two Guy Lines being tensioned to ensure the mast is standing straight, and is not bending too far towards one side (Figure 3-8). Adjust the appropriate Guy Line as necessary to keep the mast plumb vertically. Check one day after initial install. Check periodically afterwards.

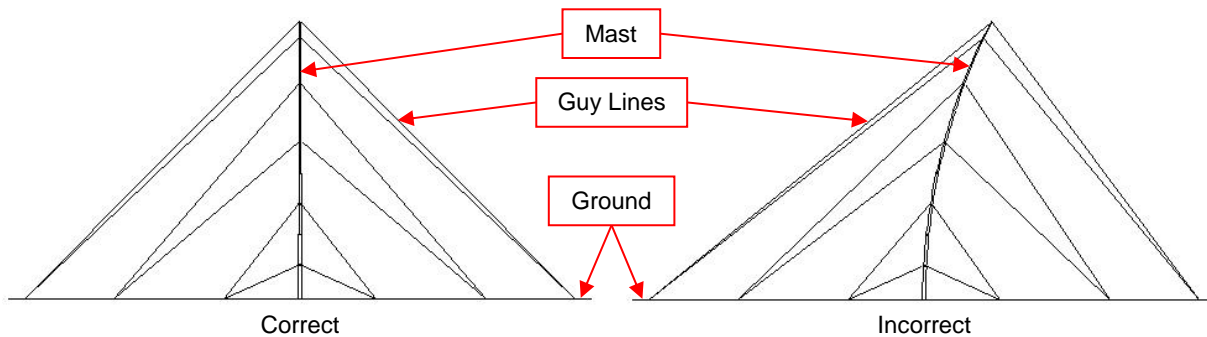

Figure 3-8 Vertically Align the Mast (Sample Shown with 6 Level Guying)

15. Open the Drain Cock for prolonged deployment to release air pressure and allow for drainage of water which may enter the mast. The Drain Cock shall be opened while a locking mast is deployed and depressurized to drain water.

3.3.3.2 Lower the Mast

⚠ WARNING

Pinch Point Hazard! Moving parts can crush and cut resulting in death or serious injury. Keep clear of moving parts while operating mast.

⚠ CAUTION

Frozen Water Hazard! Water freezing inside mast or air fittings may render mast inoperable and cause major equipment damage. Open Drain Cock, when mast is not in operation. The Drain Cock shall be installed at the lowest position in the Pneumatic System. Cover locking masts when not in use. Non-locking masts stored outdoors should be covered if possible. Will-Burt P/N: 902989 is available from Will-Burt.

To lower the mast:

1. Ensure the payload will have enough clearance when nested. For applications using a Rotatable Base Plate, if necessary, rotate the mast (Section 3.3.3.1, Step 13) so the payload will have the necessary clearance to nest.
2. Close the Drain Cock.

3. If Guy Lines are used, decrease the tension on Guy Lines until there is slack in the lines. Never attempt to unlock a mast collar with tension on the Guy Lines above it. When decreasing tension on the Guy Lines, begin at two locations opposite of each other, and gradually decrease tension on each Guy Line while observing to ensure the mast is not bending too far towards one side.

Note: Do not leave Mast Systems that requiring Guy Lines unguyed. If the Mast System has not been lowered, and personnel will not be available to operate the Guy Lines, re-guy the mast.

4. Pressurize the mast to lift the payload weight off the Latch Pins. The Latch Pins should move freely with proper pressure. Do not over-pressurize the mast. Over-pressurizing the mast could cause locks to jam.
5. While pressurizing the mast, lightly pull down the bottom T-Handle attached to the largest collar. Do not pull hard, tug, or jerk on the T-Handle, or damage to the mast locks could occur. Typically, only approximately 5 to 10 lb. (2.3 to 4.5 kg) of pressure will be necessary.

You should feel the locks open without needing to apply substantial pressure. Observe the Latch Levers to confirm they have unlocked. When unlocked, they should both be pointing down at about a 45° angle from the collar ears.

6. Exhaust air from the mast while continuing to hold down the T-Handle until the internal tube is retracted. The mast will retract by its own weight, and the weight of the payload. Maintain visual contact with the mast during retraction to avoid cable and/or payload hang-ups.

For systems using Guy Lines, gently pull Guy Lines away from the mast as it is lowered. Keeping Guy Lines organized will facilitate coiling the Guy Lines for storage, or preparing the Guy Lines for the next mast extension.

7. When the internal tube is retracted, stop exhausting air from the mast, and release the T-Handle. The spring-loaded Latch Pins will lock this tube in the nested position.
8. Repeat the same procedure for each subsequent tube going from largest to smallest until the mast is completely nested.
9. Periodically open the Drain Cock when exhausting the mast to drain off any accumulated water.
10. Disconnect the Air Supply while the mast is not in use to eliminate the possibility of inadvertent mast extension.
11. Remove the Guy Lines.
12. Remove the payload.
13. Fit the Mast Top Cover over the mast and secure it in place to protect the mast from water and debris.
14. Open the Drain Cock when the mast is not in use.

Note: The operator should always visually confirm the mast is entirely retracted before moving the vehicle. For further information on transporting the Mast System, see Section 4.

3.3.4 Locking Mast with Trip Lines Operation

The following are detailed steps of operation of the locking mast with Trip Lines. Trip Lines are used to enable a mast to be guyed as it is being extended. As appropriate, guy each section according to the Guy Kit before extending the next section.

3.3.4.1 Extend the Mast

This section describes extending the mast. Depending on the system configuration, it is possible to extend the mast with either powered or manual operation. When manually operating the mast, ensure all electrical circuits are de-energized and properly tagged to prevent injury during operation.

As mast tubes extend, they force water out of the weep holes. Keep any personnel or sensitive equipment away from the weep hole direction while extending the mast.

To extend the mast:

1. Prepare the Mast System for Operation (Section 3.3.1).
2. Remove the Mast Top Cover.
3. Secure the payload to the mast (Section 2.12).
4. Attach the Guy Lines to the color-coded lugs on the collars. If Cable Guides are present, ensure the Guy Lines are outside the Cable Guides for the collars below where they attach (Figure 3-9).

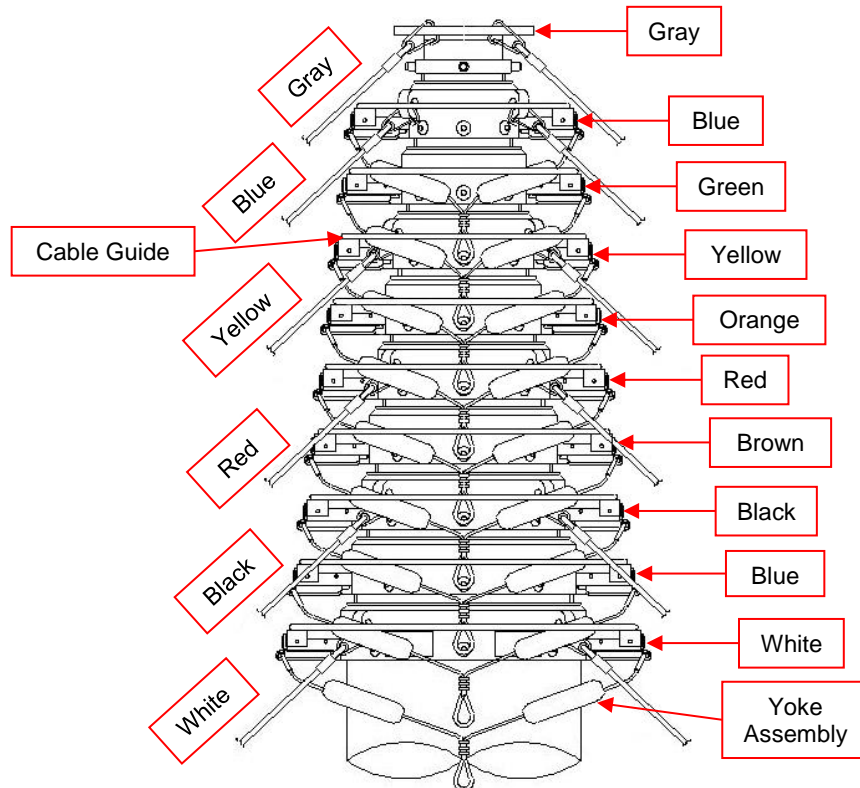

Figure 3-9 Sample of Guy Line Attachment on a Mast with Cable Guides (Mast with Trip Lines Shown)

5. Attach the color-coded Trip Lines to the matching colored Yoke Assemblies.
6. If Cable Guides are present, feed the Trip Lines under the Cable Guides on all collars up to the collar where they are to be attached. The color sequence for the Trip Lines from largest to smallest tube diameter is white (11.25), blue (10), black (9), brown (8.25), red (7.5), orange (6.75), yellow (6), green (5.25), blue (4.5), and white (3.75). Depending on the configuration of your mast, all Trip Lines may not be used.

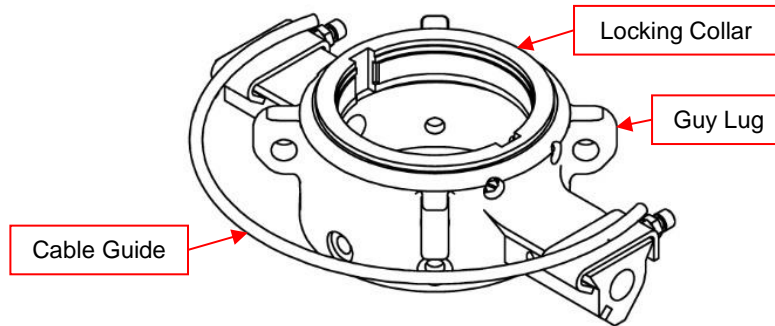

Figure 3-10 Cable Guide on Collar (Mast Tubes Removed for Clarity)

7. Prior to extending the mast, Will-Burt recommends laying out the Guy Lines and Trip Lines so they do not become tangled during extension (Figure 3-4).

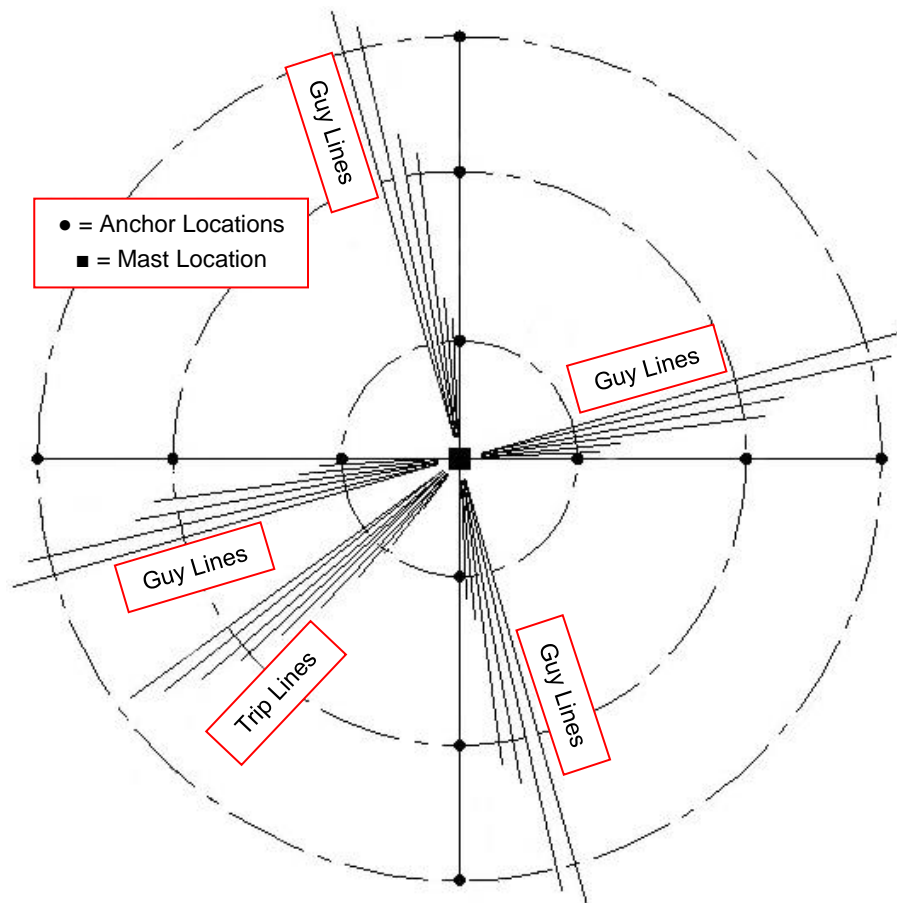

Figure 3-11 Sample of Laying Out Guy Lines and Trip Lines (Mast with 4 Way 5 Level Guying Shown)

8. Ensure the payload will have enough clearance as the mast is extended.
9. With the mast depressurized, lightly pull down on the bottom Trip Line attached to the largest collar. Do not pull hard, tug, or jerk on the Trip Line, or damage to the mast locks could occur. Typically, only approximately 5 to 10 lb. (2.3 to 4.5 kg) of pressure will be necessary.

Note: The tubes of a mast with Trip Lines are extended from largest to smallest.

10. Pressurize the mast while continuing to hold down the Trip Line. While pressurizing the mast, you should feel the locks unlatch without needing to apply substantial pressure. Observe the Latch Levers (Figure 3-12) to confirm they have unlatched. When unlocked, they should both be pointing down at about a 45° angle from the collar ears. It is possible for the Latch Levers to be at a slight angle and still be latched.

Continue holding down the T-Handle until the mast tube is fully extended.

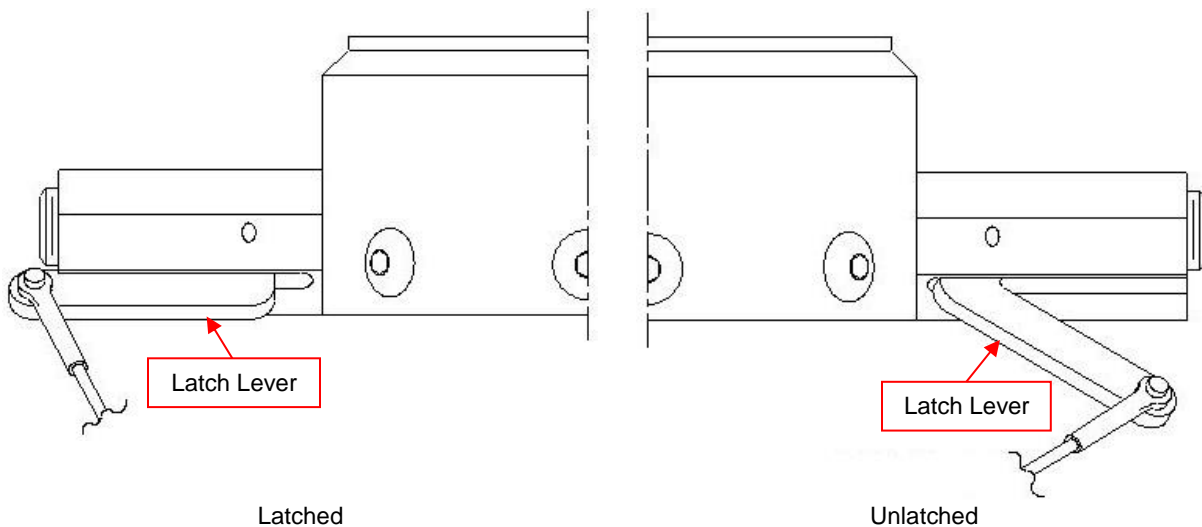

Figure 3-12 Latch Lever Positions

Maintain visual contact throughout extension to avoid overhead obstructions and to ensure none of the cables become tangled or snag on anything. Do not over-pressurize the mast. Over-pressurizing the mast could cause locks to jam. Do not exceed the maximum recommended operating pressure of the mast at any time. The maximum recommended operating pressure is:

- 20 PSIG for Standard-Duty masts
 - 35 PSIG for Heavy-Duty and Super-Heavy-Duty masts
11. When the tube is fully extended, release the Trip Line and stop pressurizing the mast. The spring-loaded Latch Pins will lock this tube in the extended position.
 12. Exhaust all air from the mast to confirm the tube is locked. If the tube comes down, repeat steps 8 to 12.

- Repeat the same procedure for each subsequent tube going from largest to smallest. Stop extending the mast when the desired height is achieved. Any combination of tubes can be extended if the full height of the mast is not required.

Properly secure and tension the Guy Lines immediately after any guyed section is raised. The installer shall verify the Guy Anchor point strength is adequate to support the Guy Line forces. All Guy Lines should be equally tensioned. Beginning at two locations opposite each other, gradually tension each Guy Line. Vertical alignment of the mast is accomplished by observing the mast perpendicularly to the two Guy Lines being tensioned to ensure the mast is standing straight, and is not bending too far towards one side (Figure 3-13). Adjust the appropriate Guy Line as necessary to keep the mast plumb vertically. Check one day after initial install. Check periodically afterwards.

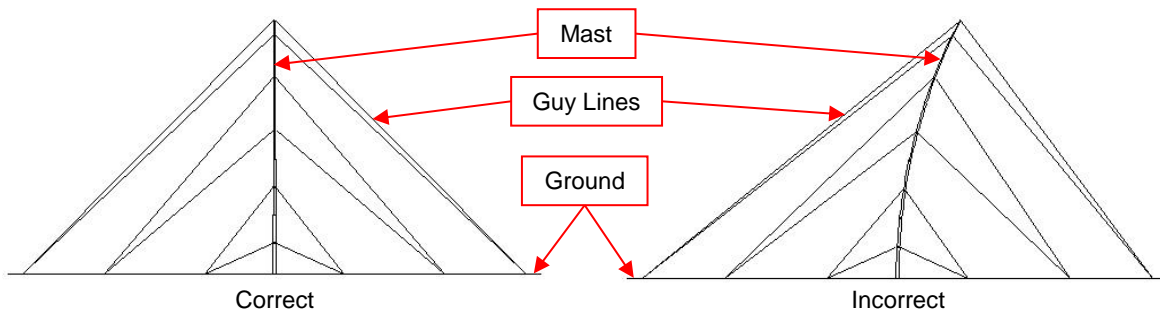

Figure 3-13 Vertically Align the Mast (Sample Shown with 6-Level Guying)

Note: When leaving a mast partially extended in potentially freezing conditions, follow the *Weatherizing Instructions for Pneumatic Masts* (TP-4744301).

- Exhaust all air.
- Open the Drain Cock for prolonged deployment to release air pressure and allow for drainage of water which may enter the mast. The Drain Cock shall be opened while a locking mast is deployed and depressurized to drain water.

3.3.4.2 Lower the Mast

⚠ WARNING

Pinch Point Hazard! Moving parts can crush and cut resulting in death or serious injury. Keep clear of moving parts while operating mast.

⚠ CAUTION

Frozen Water Hazard! Water freezing inside mast or air fittings may render mast inoperable and cause major equipment damage. Open Drain Cock, when mast is not in operation. The Drain Cock shall be installed at the lowest position in the Pneumatic System. Cover locking masts when not in use. Non-locking masts stored outdoors should be covered if possible. Will-Burt P/N: 902989 is available from Will-Burt.

To lower the mast:

1. Ensure the payload will have enough clearance when nested.
2. Close the Drain Cock.
3. Decrease the tension on the uppermost Guy Lines until there is slack in the lines. Never attempt to unlock a mast collar with tension on the Guy Lines above it. Guy Lines to mast sections not currently being lowered should remain tensioned. When decreasing the tension on the Guy Lines, begin at two locations opposite of each other, and gradually decrease tension on each Guy Line while observing to ensure the mast is not bending too far towards one side.

Note: Do not leave Mast Systems that requiring Guy Lines unguyed. If the Mast System has not been lowered, and personnel will not be available to operate the Guy Lines, re-guy the mast.

4. Pressurize the mast to lift the payload weight off the Latch Pins. The Latch Pins should move freely with proper pressure. Do not over-pressurize the mast. Over-pressurizing the mast could cause locks to jam.
5. While pressurizing the mast, lightly pull down on the top Trip Line attached to the smallest collar. Do not pull hard, tug, or jerk on the Trip Line, or damage to the mast locks could occur. Typically, only approximately 5 to 10 lb. (2.3 to 4.5 kg) of pressure will be necessary.

You should feel the locks open without needing to apply substantial pressure. Observe the Latch Levers to confirm they have unlocked. When unlocked, they should both be pointing down at about a 45° angle from the collar ears.

6. Exhaust air from the mast while continuing to hold down the Trip Line until the Top Tube is retracted. The mast will retract by its own weight, and the weight of the payload. Maintain visual contact with the mast during retraction to avoid cable and/or payload hang-ups.

Gently pull Guy Lines and Trip Lines away from the mast as it is lowered. Keeping Guy Lines and Trip Lines organized will facilitate coiling the lines for storage, or preparing the lines for the next mast extension

7. When the Top Tube is retracted, stop exhausting air from the mast, and release the Trip Line. The spring-loaded Latch Pins will lock this tube in the nested position.
8. Repeat the same procedure for each subsequent tube going from smallest to largest until the mast is completely nested.
9. Periodically open the Drain Cock when exhausting the mast to drain off any accumulated water.
10. Disconnect the Air Supply while the mast is not in use to eliminate the possibility of inadvertent mast extension.
11. Remove the Guy Lines.
12. Remove the Trip Lines.
13. Remove the payload.
14. Fit the Mast Top Cover over the mast and secure it in place to protect the mast from water and debris.
15. Open the Drain Cock when the mast is not in use.

Note: The operator should always visually confirm the mast is entirely retracted before moving the vehicle. For further information on transporting the Mast System, see Section 4.

Section 4 Transportation

Before transporting the Mast System, the Mast System needs to be secured. The exact procedures for transportation will vary based on the Mast System configuration. The process described in this manual represents a possible method of transporting the mast. Depending on the environment and equipment available, other methods may work better. Use the best and safest method for your circumstances.

WARNING

Safety Instruction – Rapid Release of Air Pressure! If the Mast System air pressure is not fully discharged prior to removing the Air Hoses, a rapid release of air pressure will occur causing a need for hearing and eye protection.

4.1 General Transportation

To prepare the Mast System for transportation:

1. Ensure the mast is fully nested (Section 3.3). Do not transport the Mast System with the mast and payload extended. Always visually confirm the mast is fully retracted before moving the mast.
2. Ensure the Air Supply is disconnected and the Drain Cock is open to eliminate the possibility of inadvertent mast extension.
3. If possible, remove and secure the payload. For locking masts, the payload should be removed, and the Mast Top Cover fitted over the mast and secured in place.
4. If necessary, secure any additional components in the Mast System.

Note: The operator should always visually confirm the mast is entirely retracted before moving the vehicle.

4.2 Shipping

When shipping the Mast System, The Will-Burt Company recommends shipping the mast in the original shipping crate. If the original shipping crate is not available, contact The Will-Burt Company to order a replacement.

When shipping:

1. As necessary, remove the payload.
2. As necessary, prepare the Mast System for transportation (Section 4.1).
3. As necessary, uninstall the Mast System from the mounting structure (Section 2).
4. Secure the Mast System in the shipping crate:
 - a. Carefully position the mast in the crate.
 - b. When shipping by air, ensure the Air Inlet Port is open.
 - c. Secure the block at the top of the mast to prevent the mast from shifting in the shipping crate during transportation.
 - d. Secure the top half of the wooden mast saddles.
 - e. As necessary, carefully pack any additional components in the shipping crate.
 - f. Secure the lid on the shipping crate.

Section 5 Maintenance

This section describes maintenance procedures required to keep the Mast System operational. Use care to understand and follow all precautions while performing these procedures. If the system does not perform as required, see Section 7.

5.1 Pre-Maintenance Check

Before performing maintenance procedures, ensure:

- All operators read and understand the entire maintenance procedure and are properly trained.
- The payload is removed prior to performing maintenance on the system.
- The system is level and secure.
- The following precautions are understood and followed:

⚠ WARNING

Fire Hazard! Cleaning solvent, used for maintenance, is flammable and can be explosive resulting in death or serious injury. Do not smoke. Use cleaning solvent in a well-ventilated area. Keep cleaning solvent away from ignition sources. Always store cleaning solvent in the proper marked container.

⚠ WARNING

Health and Safety Hazard! Solvent used to clean parts is potentially dangerous. Follow solvent manufacturer's safety procedures and recommendations. Avoid inhalation of fumes and also prolonged contact to skin. Death or serious injury could occur if solvents are not handled properly.

⚠ WARNING

Safety Instruction – Rapid Release of Air Pressure! If the Mast System air pressure is not fully discharged prior to removing the Air Hoses, a rapid release of air pressure will occur causing a need for hearing and eye protection.

⚠ WARNING

Safety Instruction – Observe Proper Procedures! Use extreme caution while lifting the Mast System and when Mast System is suspended to avoid injury and equipment damage. Be certain the Mast System is properly secured. All operators should be aware of and follow the applicable local, regional, and national standards and codes of practice for slinging and transporting equipment. Never lift Mast System over people. Ensure lifting equipment including, but not limited to, lifting straps and hoist, are capable of handling the forces generated from lifting the system. Observe manufacturer instructions on lifting equipment. Death or serious injury could result if proper procedures are not followed.

⚠ WARNING

Safety Instruction – Power! Make sure all power has been disconnected prior to performing maintenance.

⚠ CAUTION

Equipment Damage – Qualified Personnel! All persons installing and maintaining this equipment should be suitably qualified and work to local, regional, and national standards and codes of practice.

⚠ CAUTION

Equipment Damage – Forces! Before unloading the system, be certain the unloading region is capable of resisting forces generated from unloading the system including but not limited to system weight. Ensure the unloading region is level and has sufficient room and strength to hold the system. If the unloading region is incapable of meeting the requirements of the system, damage to the system and/or unloading region could occur.

⚠ CAUTION

Lifting Hazard – Manually Lifting! Manually lifting over 55 lb. (25 kg) is prohibited. In the UK, all lifting equipment must be thoroughly examined annually by a competent person according to the Lifting Operations and Lift Equipment Regulations 1998. Equivalent regulations exist in other EU states.

⚠ CAUTION

Pressurized Device Hazard! Mast disassembly prior to depressurization may release pressurized air jet. Completely lower the mast, depressurize and shut down power before disassembly. Ensure the over-pressurization safety valve is installed in the system.

⚠ CAUTION

Safety Instruction – Roof Access! If mast will be mounted to a vehicle, the operator must provide safe means to access the roof of the vehicle during installation and maintenance.

5.2 Maintenance Equipment

Table 5-1 lists recommended equipment for maintenance.

Table 5-1 Equipment Recommended for Maintenance

Recommended Equipment*		
Personal Protective		
Safety Glasses	Work Gloves	Nitrile or Vinyl Gloves
Hearing Protection	Hard Hat or Helmet	Safety Shoes
Hand Tools		
Chisel	Drill	File
Flat Punch	Hammer	Hex Wrenches
Level	Measuring Tape	Plumb-Bob
Rubber Mallet	Saw	Screwdrivers
Sockets	Torque Wrenches	Utility Knife
Wrenches		
Equipment		
Compressed Air Supply	Hoist	Ratchet Straps
Sling / Strap	Saw Horses or Similar Supports	
Expendables		
Acetone, Alcohol, or other solvent	Pipe Thread Sealant or PTFE Tape	
Rags (Clean and Dry)	Loctite® 263 (Red)	
Loctite® 380 Black Max	Loctite® 495 Instant Adhesive	
Silicone Sealant	Non-Abrasive Cleaners (Soap and Water)	
Pneumatic Mast Grease Kit (P/N: 5448701)		
* Note:		
<ul style="list-style-type: none"> Depending on the local, regional, and national standards and codes of practice, and the environment, additional personal protective equipment may be necessary. When disposing of any disposables or components, do so according to any applicable local, regional, and national standards and codes of practice. 		

5.3 Spare Parts

To order spare or replacement parts, always refer to the mast model number and serial number. The model number, serial number, and additional information is engraved on the mast Identification Plate (Section 1.5.1.5). Throughout this manual, “P/N” followed by a number represent the part number for that component. To order spare parts, or for the part numbers for additional components, contact The Will-Burt Company.

5.4 Periodic Maintenance

This section describes periodic maintenance of the system.

5.4.1 Inspections

Table 5-2 lists inspections to be done periodically.

Table 5-2 Inspections

Action	Frequency
Inspect for damage. If damage is apparent, do not use the Mast System, and have it serviced prior to use.	As needed.
Inspect to ensure the Mast System is kept clean and free from foreign material. If necessary, clean the Mast System (Section 5.4.2)	As you work and as needed. In salt water environments, clean the mast at least every 3 months.
Inspect to ensure the Drain Cock is left open when the mast is not in use, or when a locking mast is deployed and depressurized.	As every use.
Visually inspect to ensure all hardware is in place. If hardware is found loose, retighten.	Monthly.
Visually inspect to ensure all cables and hoses are undamaged and properly terminated.	Monthly.
Visually observe tube motion during extension and retraction to ensure the tubes move smoothly and do not cause excessive impact loads when each tube fully extends or retracts. Cease all mast use and contact Will-Burt Service immediately if excessive impacts are observed.	Monthly.
Cycle mast completely reaching both fully extended and fully nested.	Every 6 months. Every 3 months in salt water environments.
Weatherizing the mast (Section 5.4.3).	In potentially freezing conditions.

5.4.2 Cleaning and Lubrication

Will-Burt pneumatic masts come from the factory pre-lubricated. Under normal operating conditions, the grease applied at the factory is sufficient for five years and no scheduled maintenance is required. In extremely harsh environmental conditions, maintenance of the mast may be required.

An optional Mast Lubricant (P/N: 900600) may be added to ensure smooth operation and prolong the useful life of the mast in harsh environmental conditions. The Mast Lubricant is a blue-colored mineral oil specifically designed for telescoping masts and their operating environment. Mast Lubricant comes in a 16 oz. capped plastic bottle.

Signs cleaning and lubrication might be needed can be:

- A noticeable gritty film on the exterior surfaces of the tubes
- Erratic extension or retraction of the mast
- Noisy operation of the mast
- Sticking of one or more tubes when mast is extending or retracting

To clean the mast:

1. Will-Burt recommends removing the payload from the mast. This will allow the tubes of a non-locking mast to more easily be extended from smallest to largest. On locking masts, the sequence of extension can be controlled by locking and unlocking the collars.
2. When a regulator exists in the Pneumatic System, reduce its pressure to between 5-10 psig (0.34-0.69 bar).

Note: A pressure of 10 psig (0.69 bar) should be sufficient to extend all tubes without a payload. If any tube will not extend with 10 psig (0.69 bar), the mast may require an overhaul. Consult the factory.

3. One person, operating the Air Control Valve or switch, should slowly pressurize the mast just enough to extend the Top Tube. On non-locking masts, another person may need to hold down the Intermediate Tubes to ensure the proper sequence of extension. Close the Air Control Valve or switch as soon as the Top Tube is extended.
4. Dampen a rag with a non-abrasive cleaner or solvent such as lacquer thinner to wipe down the extended tube. Do not allow the cleaning fluid or solvent to run down inside the collar.
5. If not lubricating the mast, repeat this procedure for each tube from smallest to largest.

If lubricating the mast (optional, but helpful in extremely harsh conditions):

- a. Inject approximately ½ oz. of Mast Lubricant (P/N: 900600) into the weep hole of the exposed tube. The weep holes are located between 1 and 3 feet (30 and 91 cm) below the collar on each tube except the Top Tube. Do not lubricate the exterior of the mast. This attracts dust and contaminants from the air.
- b. Repeat 3, 4, and 5a for each of the remaining tubes. The larger diameter tubes should be injected with approximately 1 oz. of lubricant.

- c. Lower the mast completely. Allow several minutes for the lubricant to settle and spread around the Wear Ring and Seal at the bottom of each tube.
- d. Extend the mast again, one tube at a time from smallest to largest. Wipe off any excess lubricant that flows out of the weep holes.

5.4.3 Weatherizing

For weatherizing your mast in extremely harsh environmental conditions, The Will-Burt Company recommends following the *Weatherizing Instructions for Pneumatic Masts* (TP-4744301). See www.willburt.com for these instructions. These instructions assume the use of the Pneumatic Mast Antifreeze Kit (P/N: 4725801).

The Pneumatic Mast Antifreeze Kit includes:

- (1) Flush Caution Label
- (1) Gallon Will-Burt Non-Toxic Pneumatic Mast Antifreeze with MSDS
- (1) Will-Burt Non-Toxic Pneumatic Mast Antifreeze Application Bottle
- (1) Mast Lubricant with MSDS and Service Sheet
- (1) Copy of the *Weatherizing Instructions for Pneumatic Masts* (TP-4744301)

Will-Burt Non-Toxic Pneumatic Mast Antifreeze (P/N: 473801) can also be purchased by the gallon.



Figure 5-1 Application Bottle and Gallon of Will-Burt Non-Toxic Pneumatic Mast Antifreeze

5.5 Corrective Maintenance

This section describes corrective maintenance for the system. Depending on the Mast System configuration and the conditions of the Mast System, all corrective maintenance procedures may not be required. Follow the appropriate instructions for your Mast System.

Prior to performing corrective maintenance, remove the:

- Payload from the mast
- Mast from the mounting structure.

For reference information on tube diameters and collar dimensions, see Section 8.2.

5.5.1 Replace Seals on Standard-Duty Masts

This section describes replacing the Seals on Standard-Duty masts. For information on replacing the Seals, Expanders, and Yoke Assemblies on Heavy-Duty and Super-Heavy-Duty masts, see Section 5.5.2.

Disassemble the mast starting with the Top Tube and working towards the Base Tube. Remove any plugs from the Air Inlet Ports.

To disassemble the mast:

1. Place the mast horizontally on a pair of sawhorses or similar supports. Secure the Base Tube to the supports so the mast does not roll off. Use care to follow all applicable lifting precautions whenever lifting the mast or components of the mast.
2. Start disassembly from the top by pulling the Top Tube several inches away from the collar.
3. Remove the Top Tube Stop.
4. Remove the collar bolts on the top collar and slide the collar over the end of the tube.
5. Pull out the Top Tube and set it aside. Use care not to drop the tube as it comes out. Tubes can be very heavy. Two or three people or the use of a hoist is required. Use care to follow all applicable lifting precautions whenever lifting the mast or components of the mast.
6. Remove the Wear Ring from the Butt Plate and wipe it clean.
7. Remove the old Seal and clean the Seal groove.
8. Thoroughly clean and inspect the inside and outside of the tube with a solvent such as lacquer thinner. Do not use anything that might scratch the honed inside surface of the tube. Tubes may need to be cleaned repeatedly before reassembly to remove all debris.
9. Repeat steps 4 through 8 for each subsequent tube. Be careful not to damage or oblong collar bolt holes when removing the tubes.

10. As necessary, refer to the appropriate section(s) for replacement steps for the following:
 - a. Replacement of the Collar Bearing Strips (Section 5.5.3)
 - b. Replacement of the Wear Rings (Section 5.5.4)
 - c. Replacement of the Collar Inserts (Non-Locking Masts) (Section 5.5.5)
 - d. Replacement of the Internal Bumpers (Section 5.5.6)
 - e. Replacement of the External Bumpers (Section 5.5.7)
11. Oil the new Seal with the Pneumatic Mast Grease Kit (P/N: 5448701). With the lip edge of the Seal toward the bottom end of the tube, slide it on the Butt Plate and into the Seal groove. Replace the Wear Ring on the Butt Plate. Repeat this procedure for each tube.
12. Before reassembling the mast, use the Pneumatic Mast Grease Kit to lightly oil the lip of the Seal and the inside honed surface of each tube, except the Top Tube. When reassembling the mast, begin with the Base Tube and work towards the Top Tube.
13. Secure the Base Tube horizontally on saw horses or similar supports.
14. Using a second person or a brace to support the top end, hold the next tube so the top end of the tube is at a lower elevation than the Seal end. Rest the lip of the Seal on the inside of the receiving tube (Figure 5-2). Use care to follow all applicable lifting precautions whenever lifting the mast or components of the mast.

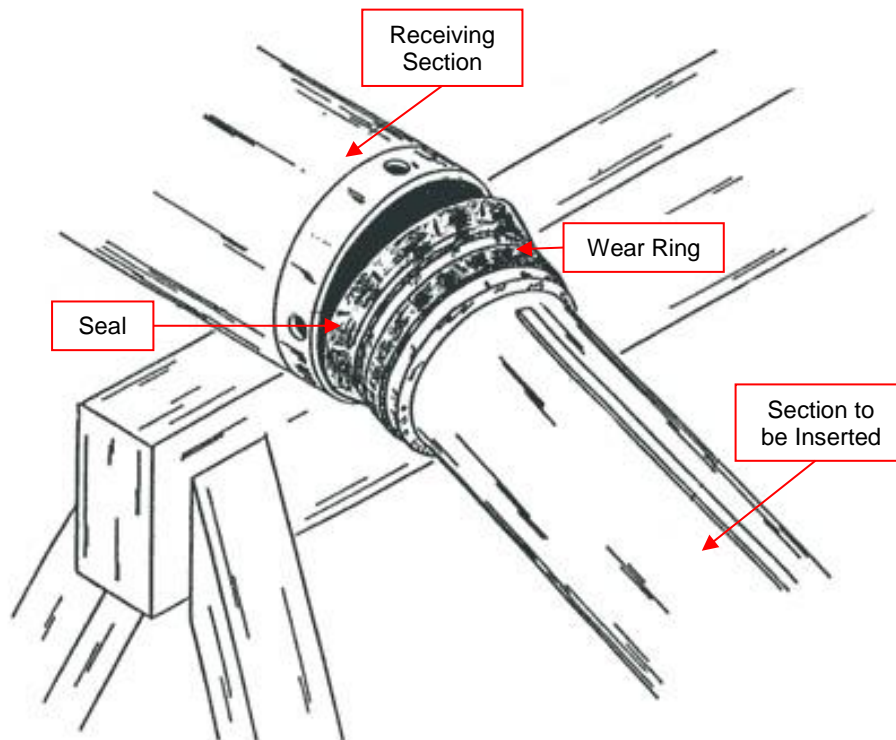

Figure 5-2 Seal Replacement

15. Slowly raise the lower end of the tube to horizontal while carefully pressing the lip of the Seal into the receiving tube. Use your thumbs and forefingers to press simultaneously on both sides of the Seal in an upward motion. Work this way until your fingers meet at the top.
16. Ensure the Seal is in properly. If not, the mast will eventually leak air. If the Seal has not been inserted into the receiving tube correctly, remove the tube and repeat the process.
17. Once the Seal is inserted, guide the Wear Ring into position within its groove and slide in the tube. Be careful not to damage the Seal as it slides past the collar bolt holes that are located near the insertion end of the receiving tube.
18. Slide the tube in leaving several inches protruding. Rotate the tube so the "0" stamps on the tubes are aligned.
19. Replace the collar on the tube. Align the "0" stamp on the collar with the "0" stamp on the tube. Ensure all bolt holes in the collar align exactly with the holes in the tube. Install and hand-tighten the collar bolts and lock washers. Ensure the collar bolts are wiped free of grease prior to installation. Torque the collar bolts to 100-120 in.-lb.

Note: Ensure the collar bolts engage in the holes in the tube. If collar bolts do not engage the holes in the tube, the mast can separate during extension.
20. Repeat steps 12 through 19 for each subsequent tube.

5.5.2 Replace Seals, Expanders, and Yoke Assemblies on Heavy-Duty and Super-Heavy-Duty Masts

This section describes replacing the Seals, Expanders, and Yoke Assemblies on Heavy-Duty and Super-Heavy-Duty masts. For information on replacing the Seals on Standard-Duty masts, see Section 5.5.1.

Disassemble the mast starting with the Top Tube and working towards the Base Tube. Remove any plugs from the Air Inlet Ports.

To disassemble the mast:

1. Place the mast horizontally on a pair of sawhorses or similar supports. Secure the Base Tube to the supports so the mast does not roll off. Use care to follow all applicable lifting precautions whenever lifting the mast or components of the mast.
2. Start disassembly from the top by pulling the Top Tube several inches away from the collar. On locking collar models, it is necessary to retract the Latch Pins to allow the tube to be pulled out.

3. For non-locking masts, or locking masts that do not need corrective maintenance done to the locks, skip to step 4.

For locking masts that do need corrective maintenance done to the locks:

- a. Remove the set screw from the end of each Latch Pin Lug (the ears on each side of the collar) (Figure 5-3).

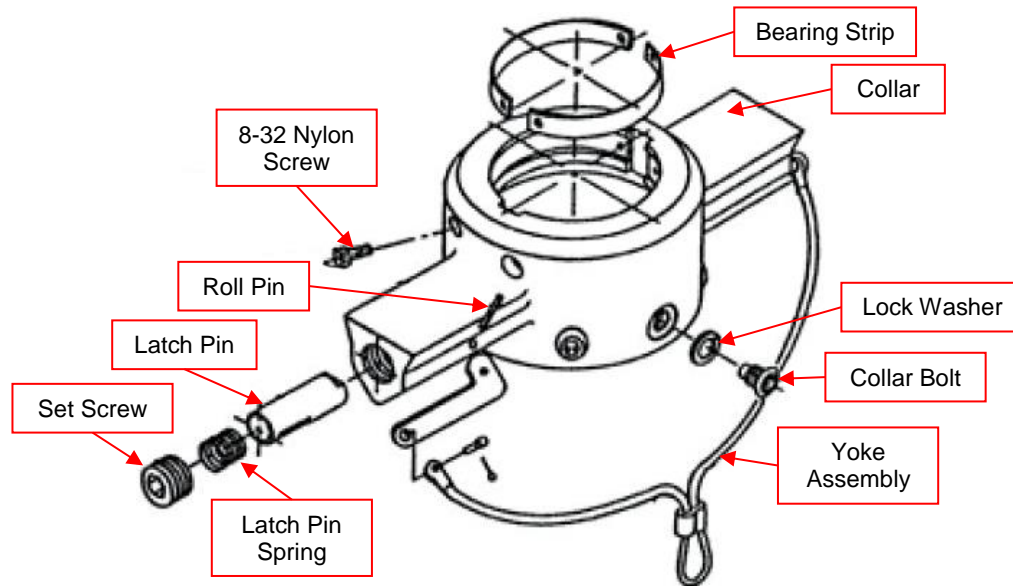

Figure 5-3 Locking Collar Assembly

- b. Slide the Latch Pin Spring from the end of each lug.
 - c. Using a hammer and a punch, drive out the roll pin on each lug just far enough to remove the Yoke Assembly.
 - d. Slide the Latch Pin out of the Latch Pin Lug using a small screwdriver inserted into the slot located on the underside of each lug.
4. Remove the collar bolts and slide the collar over the end of the tube. On locking collar models, retract the Latch Pins fully to allow the collar to slide off the end of the tube.
 5. Pull out the Top Tube and set it aside. Use care not to drop the tube as it comes out. Tubes can be very heavy. Two or three people or the use of a hoist is required. Use care to follow all applicable lifting precautions whenever lifting the mast or components of the mast.

6. Remove the Orifice Bolt, lock washer, Backup Washer, Expander, and Seal from the bottom of the tube. Note the Orifice Bolt ID and corresponding tube for use when reassembling (Figure 5-4).

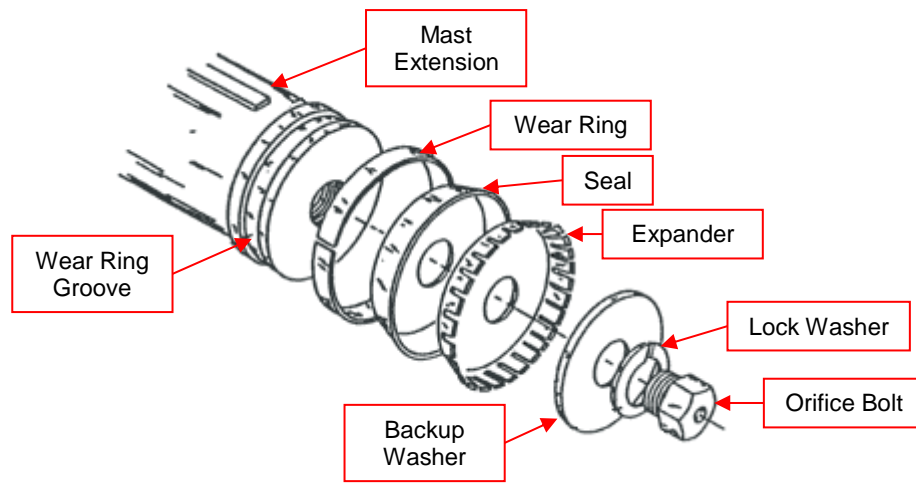

Figure 5-4 Seal Area (Heavy-Duty and Super-Heavy-Duty)

7. Thoroughly clean and inspect all parts. The tube should be cleaned inside and outside with a solvent such as lacquer thinner. Do not use anything that might scratch the honed inside surface of the tube. Tubes may need to be cleaned repeatedly before reassembly to remove all debris.
8. Repeat steps 4 through 8 for each subsequent tube. Be careful not to damage or oblong collar bolt holes when removing the tubes.
9. As necessary, refer to the appropriate section(s) for replacement steps for the following:
 - a. Replacement of the Collar Bearing Strips (Section 5.5.3)
 - b. Replacement of the Wear Rings (Section 5.5.4)
 - c. Replacement of the Collar Inserts (Non-Locking Masts) (Section 5.5.5)
 - d. Replacement of the Internal Bumpers (Section 5.5.6)
 - e. Replacement of the External Bumpers (Section 5.5.7)
10. Reassemble the Orifice Bolt, lock washer, Backup Washer, new Expander, and new Seal on the bottom of the tube. Match Orifice Bolts with the correct tube by using the Orifice Bolt ID and tube OD. The ID of the Orifice Bolts should decrease as the tube OD decreases. For example, the top tube will have the smallest tube diameter and the Orifice Bolt with the smallest ID.

As the Orifice Bolt is being tightened, center the Seal, Expander, and Backup Washer on the Butt Plate. Torque the Orifice Bolt to 16 ft.-lb. Repeat this procedure for each tube.

11. Before reassembling the mast, use the Pneumatic Mast Grease Kit (P/N: 5448701) to lightly oil the lip of the Seal and the inside honed surface of each tube, except the Top Tube. When reassembling the mast, begin with the Base Tube and work towards the Top Tube.

12. Secure the Base Tube horizontally on saw horses or similar supports.
13. Using a second person or a brace to support the top end, hold the next tube so the top end of the tube is at a lower elevation than the Seal end. Rest the lip of the Seal on the inside of the receiving tube (Figure 5-5). Use care to follow all applicable lifting precautions whenever lifting the mast or components of the mast.

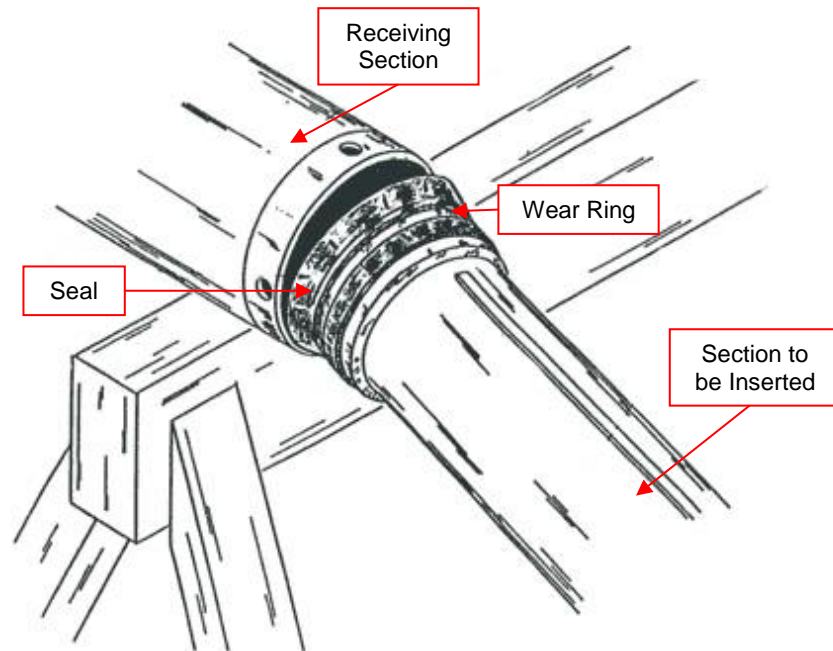

Figure 5-5 Seal Replacement

14. Slowly raise the lower end of the tube to horizontal while carefully pressing the lip of the Seal into the receiving tube. Use your thumbs and forefingers to press simultaneously on both sides of the Seal in an upward motion. Work this way until your fingers meet at the top.
15. Ensure the Seal is in properly. If not, the mast will eventually leak air. If the Seal has not been inserted into the receiving tube correctly, remove the tube and repeat the process.
16. Once the Seal is inserted, guide the Wear Ring into position within its groove and slide in the tube. Be careful not to damage the Seal as it slides past the collar bolt holes that are located near the insertion end of the receiving tube.
17. Slide the tube in leaving several inches protruding. Rotate the tube so the “0” stamps on the tubes are aligned.
18. Replace the collar on the tube. Align the “0” stamp on the collar with the “0” stamp on the tube. On locking masts, retract the Latch Pins to allow the collar to slide onto the end of the tube. Ensure all bolt holes in the collar align exactly with the holes in the tube. Install and hand-tighten the collar bolts and lock washers. Ensure the collar bolts are wiped free of grease prior to installation. Torque the collar bolts to 100-120 in.-lb.

Note: Ensure the collar bolts engage in the holes in the tube. If collar bolts do not engage the holes in the tube, the mast can separate during extension.

19. Replace the Yoke Assembly as follows:
 - a. Replace the Latch Pins with the flats on the ends perpendicular to the key on the mast tube.
 - b. Replace the Yoke Assembly. Ensure the hole in the Latch Lever lines up with the hole in the Latch Ear. Drive in the Roll Pin while holding it in place with a Punch. Ensure that the Latch Lever does not get jammed.
 - c. Install the Latch Pin Spring and Set Screw. Turn the Set Screw all the way until it stops. Then back out the Set Screw approximately $\frac{1}{4}$ to $\frac{1}{2}$ turn.
 - d. Repeat this procedure for the other Latch Ear.
 - e. Check the Yoke Assembly for smooth operation. It may be necessary to readjust the Set Screw as much as one full turn. If the Set Screw is too tight, it may not allow the Latch Pin to retract fully when the Yoke Assembly is pulled. If the Set Screw is too loose, spring tension may not adequately load the Latch Pin.
 - f. While pulling the Yoke Assembly, slide the mast section through the collar several times. Check for smooth operation. Observe the flat surface on the keys of the mast for wear marks. If wear marks exist, the Latch Pin is causing friction, and the Set Screw must be loosened.
20. Repeat this procedure for each subsequent tube.

5.5.3 Replace Collar Bearing Strips

This section describes replacement of Collar Bearing Strips. Some collars have Collar Inserts instead. For information on replacing Collar Inserts, see Section 5.5.5.

Inspect the Bearing Strip (Figure 5-6) and the machined keyways of the collar for wear. If the keyways of the collar are badly worn, the collar should be replaced. If the Bearing Strips are worn down to the metal collar, they should be replaced.

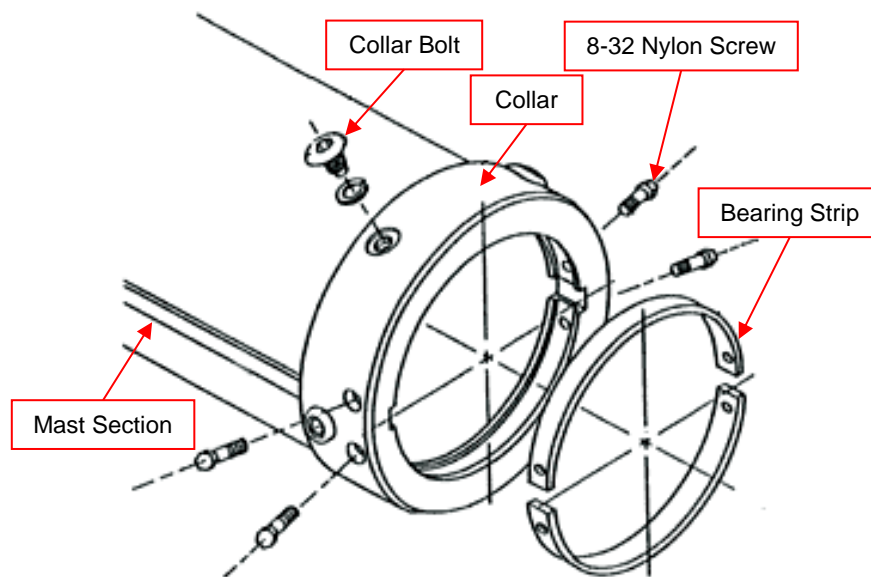

Figure 5-6 Bearing Strip and Keyway

To replace the Bearing Strips:

1. Remove the nylon screws from the collar.
2. Pull out the Bearing Strips and clean the collar.
3. Press the new Bearing Strips firmly into the groove.
4. Align the holes in the Bearing Strips with those in the collar.
5. Install and hand-tighten the new nylon screws through the collars into the threaded holes for the Bearing Strip. Apply Loctite® 495 Instant Adhesive or equivalent to the nylon screws before installation. Do not overtighten the nylon screws.
6. Cut off or file off the ends of the nylon screws protruding through the Bearing Strips until they are flush.
7. Carefully file off any excess Bearing Strip that may protrude into the keyway of the collar.
8. Before reassembling the mast, slide each collar over its mating tube. If the collar does not slide freely over the tube, it will be necessary to sand high spots on the Bearing Strip to fit. The high spots will be evident by shiny or gray marks on the white Bearing Strip.
9. Wipe the collars clean before reassembling the mast.

5.5.4 Replace Wear Rings

Wear Rings are preformed split synthetic bearings that fit around the Butt Plate above the Seal on each interior tube. Wear Rings can be replaced when the mast is disassembled for Seal replacement. Check the Wear Rings for wear. If the Wear Ring is worn down to the Butt Plate surface, it must be replaced.

The following are instructions to replace the Wear Rings in Standard-Duty and Heavy-Duty mast. For instructions on replacing Wear Rings on Super-Heavy-Duty masts, refer to *Super-Heavy-Duty Pneumatic Mast Wear Ring Installation (TP-5362201)*.

To replace the Wear Rings:

1. Clean the Butt Plate and Wear Ring groove (Figure 5-7).

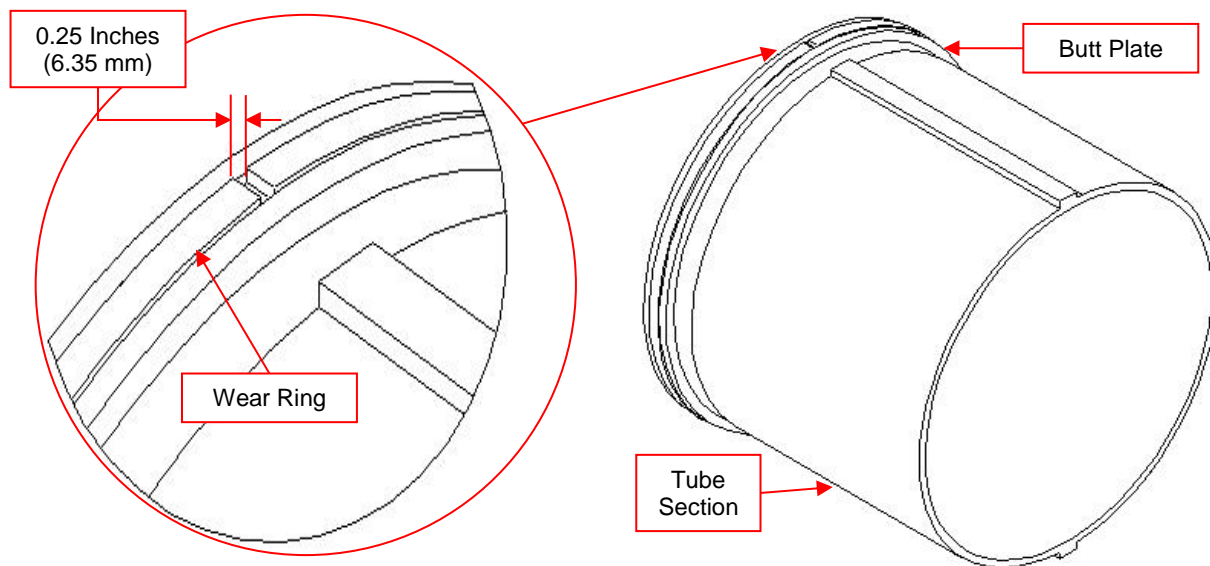

Figure 5-7 Replacing Wear Rings

2. Slide the Wear Ring over the mast and into the groove. Press the Wear Ring into the groove to make sure there is at least $\frac{1}{4}$ inch (6.35 mm) clearance between the two ends (Figure 5-7). If necessary, cut enough off one end to get the required gap.
3. The Wear Ring must be held in place until this tube is inserted into the receiving tube. Apply a bead of adhesive inside the groove on the Butt Plate to bond the Wear Ring in place. If the Wear Ring prevents the tube from sliding inside the next tube, lightly grind the Wear Ring OD as necessary.
4. Before reassembling the tubes, slide each tube inside its mating tube. If the smaller tube does not slide freely inside the next largest tube, it will be necessary to sand high spots on the Wear Ring to fit. The high spots will appear as shiny or discolored marks on the outside diameter of the Wear Ring.

Note: On masts manufactured before 1986, Bearing Strips were cemented to the butt plates of the tubes. Wear Rings can be used to replace the old Bearing Strips in many of these masts. Consult the factory with your model and serial number for verification before ordering replacement Wear Rings.

5.5.5 Replace Collar Inserts (Non-Locking Masts)

This section describes replacement of Collar Inserts. Some collars have Collar Bearing Strips instead. For information on replacing Collar Bearing Strips, see Section 5.5.3.

Inspect the collar insert and the machined keyways in it for wear. If the keyways of the collar are badly worn (elongated), the collar insert should be replaced.

To replace the collar inserts on non-locking masts:

1. Using a knife, carefully remove the flat rubber External Bumper that is glued to the top of the collar.
2. Remove the (3) ¼-28 socket head cap screws from the collar with a hex wrench. This will allow the collar insert to be removed.
3. Carefully tap around the top edge of the collar insert with a hammer and flat punch or chisel to drive the collar insert out the bottom of the collar. The Collar Insert can only be removed from the bottom of the collar.
4. Clean the collar.
5. Install the new Collar Insert into the collar. Make sure to align the holes in the Collar Insert with the holes in the collar. It may be necessary to gently tap the Collar Insert into the collar. Use care not to damage the Collar Insert.
6. Apply adhesive, such as Loctite® 495 Instant Adhesive, to the ends of the ¼-28 socket head cap screws and replace the screws.
7. Replace the external bumper (Section 5.5.7).
8. Before reassembling the mast, slide each collar over its mating tube. If the collar does not slide freely over the tube, it will be necessary to sand high spots on the insert to fit. The high spots will appear as shiny or discolored marks on the inside diameter of the collar insert.
9. Clean the collars before reassembling the mast (Figure 5-8).

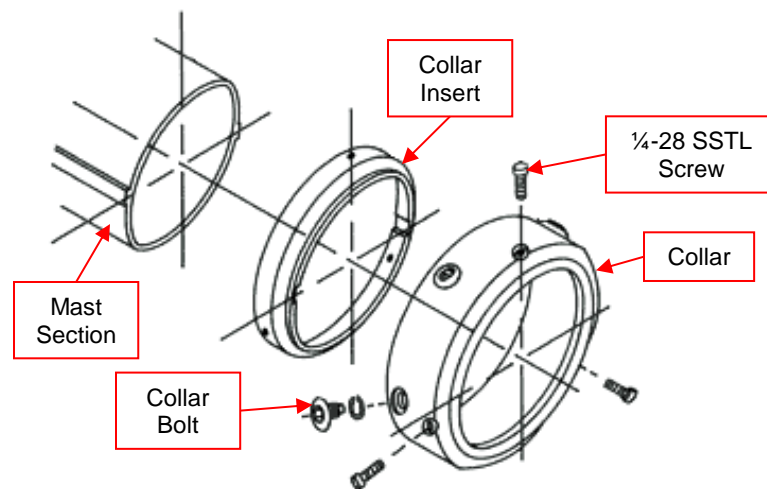

Figure 5-8 Replacing Collar Inserts

5.5.6 Replace Internal Bumpers

On locking masts, the Internal Bumper, which looks like an O-ring, is located on the top edge of the Stop Panel on each internal tube. When the mast is disassembled, check the condition of the Internal Bumper. If the Internal Bumper has deteriorated, it should be replaced.

Some older model non-locking pneumatic masts may also have an Internal Bumper. These can be removed during maintenance and do not need replaced.

To replace the Internal Bumper:

1. Remove the old Internal Bumper.
2. Carefully stretch the new Internal Bumper over the end of the tube and insert it into the groove machined in the keys. The Internal Bumper should fit tightly against the tube immediately above the Stop Panel (Figure 5-9).

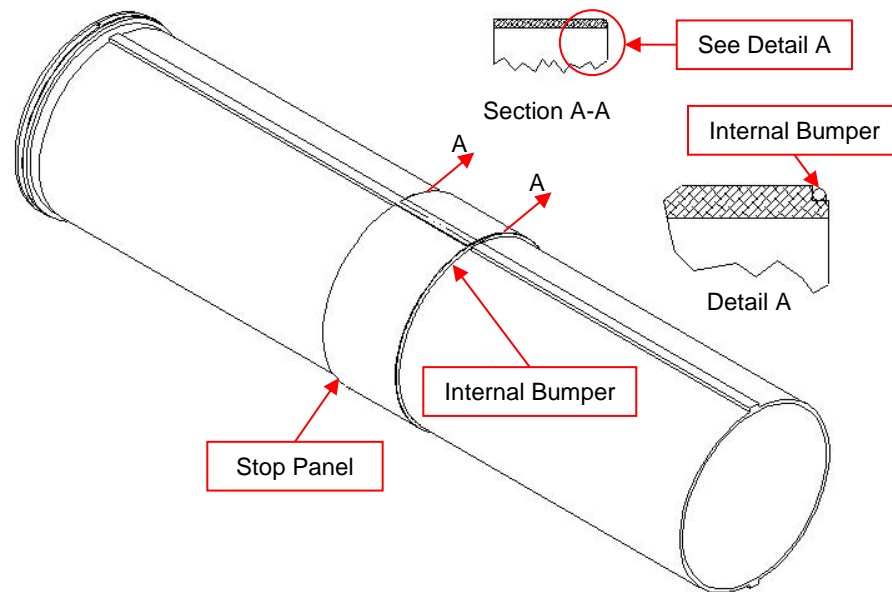

Figure 5-9 Replacing Internal Bumpers

5.5.7 Replace External Bumpers

The external bumper is a flat rubber ring cemented to the top of each mast collar. Check the condition and the adhesion of each External Bumper. If the External Bumpers become loose they can usually be reused unless they have been damaged.

To replace the External Bumpers:

1. Remove the old External Bumper.
2. Use acetone to clean off any old adhesive from the collar. Clean the replacement External Bumper with acetone. Allow it to dry thoroughly.
3. At room temperature, apply a light bead of Loctite® 380 Black Max or equivalent around the top of the collar. Follow the manufacturer's instructions.

4. Place the External Bumper on the collar and align the inside diameter edges. Hold pressure on the External Bumper and collar using a uniform weight for at least 90 seconds.
5. Using a razor knife, notch out keyways in the External Bumper to match those in the collar (Figure 5-10).

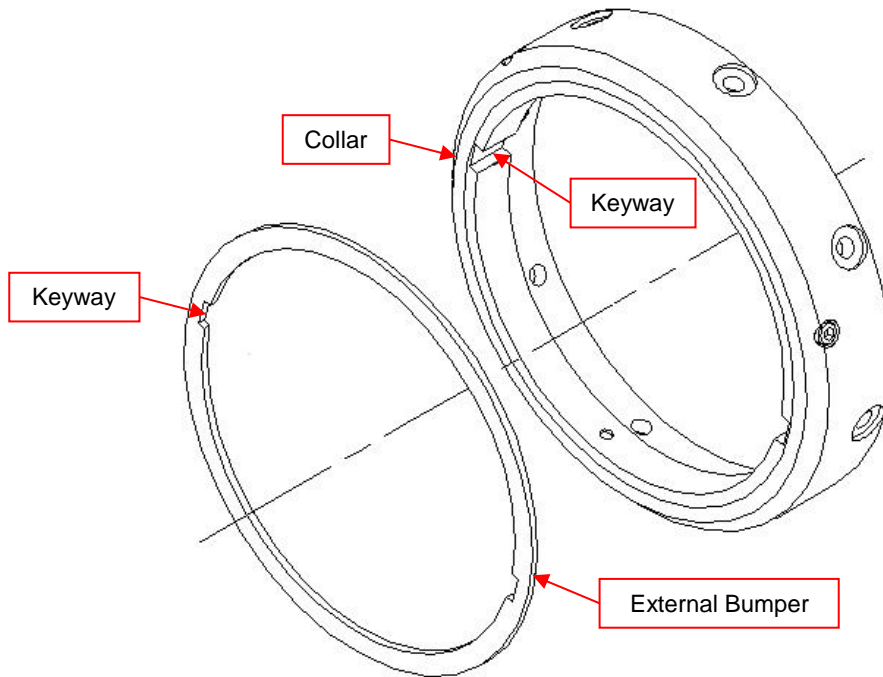

Figure 5-10 Replacing External Bumpers

Section 6 Long-Term Storage

When putting the system into long-term storage, ensure the:

- Mast is fully nested (Section 3.3)
- Drain Cock is open to eliminate the possibility of inadvertent mast extension
- Mast is stored in a clean and dry environment
- Mast is stored vertically when storing for more than six months
- Mast is extended and lowered every six months (Section 3.3)

(This page is intentionally left blank.)

Section 7 Troubleshooting

This section describes troubleshooting for the Mast System. Use care to understand and follow all precautions while troubleshooting the Mast System.

Table 7-1 Troubleshooting

Problem	Possible Cause	Possible Solution
Mast is frozen in the extended position.	Base Tube was not drained routinely. Typically freezes around collar area.	Wrap warming blankets around collar until ice melts. Use a heat gun or 500W quartz light.
		Depressurize mast. Inject 1 oz. Will-Burt Antifreeze (P/N: 4735801), where the top of the collar and Intermediate Tube meet.
	There is ice buildup on the exterior of the mast.	Follow the <i>Instructions for Clearing Ice Buildup on the Exterior of a Pneumatic Mast</i> (TP-5253501)
	Locks are stuck in the locked position due to lack of exercising.	Use Lock Pin Extractor Kit (P/N: 5448601)
Mast is frozen in nested position.	Base Tube was not drained routinely. Typically damages tubes.	Send to the manufacturer for repair or replacement.
Largest Intermediate Tube stuck	Turning Handles too tight. (Typical Standard-Duty)	Remove Turning Handles and cycle. If the mast cycles properly, reinstall the Turning Handles (Section 2.7.2.7 and 2.8.2.7). If the mast does not cycle, the tubes are damaged. Send to the manufacturer for repair or contact regarding Base Tube replacement.
	Support Bracket too tight.	Loosen shims. Shim as necessary between clamp halves.

Continued

Table 5-1 Troubleshooting Continued

Problem	Possible Cause	Possible Solution
Cannot slide Weather Bonnet over the Base Tube.	Weather Bonnets are designed to be tight.	Use soapy water per Section 2.7.2.2.
		Use a mallet to tap evenly around the diameter of the Weather Bonnet.
Mast will not lower without rocking.	Not enough weight. (Typically only with Standard-Duty)	See Section 5.4.2 for mast cleaning and lubrication.
		Add weight to Platform or Stub Adaptor.
	Bent tube.	Check tube trueness. If bent, order replacement (Section 5.3).
	Broken Internal Bumper.	Depressurize mast. Remove the collar, and lift the tube to check the Internal Bumper (Section 5.5). If necessary, order replacement (Section 5.3).
Rotational movement in tubes.	Collar Inserts tight. (Typical Heavy-Duty and Super-Heavy-Duty)	Depressurize and disassemble mast (Section 5.5). File or lightly grind to pre-fit Collar Inserts as necessary.
		Bearing Strips or inserts worn.

For additional information, please contact Will-Burt Customer Service at 330-684-5298.

Section 8 Reference

This section provides reference information for the system as follows:

- Extended Glossary of Terms (Section 8.1)
- Reference Dimensional Information (Section 8.2)
- Drawings (Section 8.3)

8.1 Extended Glossary of Terms

This section defines terms used within this manual as follows:

- General Terms and Abbreviations (Section 8.1.1)
- Mounting Position Terms (Section 8.1.2)

8.1.1 General Terms and Abbreviations

This section describes general terms and abbreviations used within this manual.

- “Amp” stands for ampere which is a unit of electric current
- “AWG” stands for American Wire Gauge
- “Bar” is a metric unit of pressure. One Bar is approximately equal to the atmospheric pressure at sea level.
- “Base Tube” refers to the tube with the largest diameter. When the mast is fully extended, this is the tube closest to the mounting surface.
- “BCD” stands for Bolt Circle Diameter
- “Bearing Strips” refer to plastic strips located in some collars where tubes make contact with each other.
- “Butt Plate” refers to the bottommost plate on each intermediate tube
- “CFM” stands for Cubic Feet per Minute
- “Collar Inserts” refer to machined pieces of plastic with a notch for the key located in some collars.
- “Collars” attach to the top of each tube except the Top Tube.
- “Drain Hole” refers to the threaded hole on the side of the Base Tube designed to facilitate the water drainage during periods of extension. A Drain Kit may be installed to the Drain Hole to route water away from the Mast System. The Base Tube has one Drain Hole.

- “Extended” refers to the partial- or full-raised position of the mast that the mast pneumatically goes to from the nested position. In the extended position, some or all the tubes have risen.
- “ft.-lb.” stands for foot-pounds, which is a unit of torque equal to the force in pounds multiplied by the distance in feet to the pivot point
- “HDL” stands for Heavy-Duty Locking
- “HDNL” stands for Heavy-Duty Non-Locking
- “Hz” stands for hertz and is defined as one cycle per second
- “ID” stands for Inside Diameter or the diameter to the inside edge of a circle
- “in.-lb.” stands for inch-pounds, which is a unit of torque equal to the force in pounds multiplied by the distance in inches to the pivot point
- “Intermediate Tubes” refer to the tubes between the Base Tube and the Top Tube.
- “LPM” stands for Liters per minute
- “Mast” to refer to the telescoping pneumatic mast
- “Mast System” to refer to the entire Pneumatic Mast System (telescoping mast, pneumatic system, mounting hardware, and additional accessories)
- “Nested” refers to the position of the mast where no tubes have risen. The mast remains retracted. This position is sometimes referred to as “stowed”.
- “NPT” stands for “American National Standard Pipe Thread” or “National Pipe Thread” for short; a United States standard for thread specifications on pipes and fittings. NPT threads are tapered.
- “OD” stands for Outside Diameter or the diameter to the outside edge of a circle
- “Payload” to refer to the object or equipment being raised by the mast to an operational height
- “PSI” stands for pound-force per square inch
- “PSIG” stands for pound-force per square inch gauge. PSIG refers to a gauge that has been calibrated to read zero at sea level.
- “P/N” stands for Part Number. These are Will-Burt part numbers for various components in the Mast System.
- “SCFM” stands for standard cubic feet per minute, or CFM adjusted to 14.7 PSI (1 Bar) and 68°F (20°C)
- “SHDL” stands for Super-Heavy-Duty Locking
- “SHDNL” stands for Super-Heavy-Duty Non-Locking
- “Top Tube” refers to the tube with the smallest diameter. When the mast is fully extended, this is the tube furthest from the mounting surface.

- “Top Tube Stop” refers to the component at the top of the Top Tube. The Top Tube Stop prevents the Top Tube from sliding too far down into a nested mast.
- “Tube Head” refers to the component at the base of the Base Tube. The Tube Head can be set up for either non-rotating masts (without a groove in the Tube Head) or rotating masts (with a groove in the Tube Head). The type of Tube Head will impact the nested height of the mast.
- “Wear Rings” are preformed split synthetic bearings that fit in the Wear Ring Groove around the Butt Plate above the Seal on each interior tube. The Wear Rings guide the bottom of the tube through the next larger tube.
- “Weep Holes” refer to the holes on the Intermediate Tubes which are designed to facilitate the drainage of water during periods of extension. Each Intermediate Tube has four Weep Holes.
- “Ø” stands for diameter

8.1.2 Mounting Position Terms

For the purposes of this manual, regions of the mounting location are defined as follows:

- “Mounting Structure” is the overall structure where the Mast is mounted.
- “Mounting Surface” is the surface to which the Base Plate is secured. When the Shelf Bracket is used (in external mount applications only), it will serve as the mounting surface for the Base Plate. When installing inside a vehicle, this will likely be the floor.
- “Roof” is the horizontal surface to which the Internal Mounting Kit is secured. This term applies to internal mount applications only.
- “Support Structure” is the vertical surface to which the External Support Bracket is secured. This term applies to external mount applications only.

8.2 Reference Dimensional Information

This section describes reference dimensional information as follows:

- Tube Diameter (Section 8.2.1)
- Collar Information (Section 8.2.2)

8.2.1 Tube Diameters

Table 8-1 Tube Diameters

Standard-Duty			
Tube	A		
	inch	mm	
2	2.0	51	
2 ½	2.5	64	
3	3.0	76	
3 ½	3.5	89	
4	4.0	102	
4 ½	4.5	114	
B 5	5.0	127	

Heavy-Duty			
Tube	A		
	inch	mm	
3	3.0	76	
3 ¾	3.75	95	
4 ½	4.5	114	
5 ¼	5.25	133	
6	6.0	152	
B 6 ¾	6.75	171	
7 ½	7.5	191	
8 ¼	8.25	210	
B 9	9.0	229	

Super-Heavy-Duty			
Tube	A		
	inch	mm	
3 ¾	3.75	95	
4 ½	4.5	114	
5 ¼	5.25	133	
6	6.0	152	
6 ¾	6.75	171	
7 ½	7.5	191	
8 ¼	8.25	210	
9 ⅛	9.125	232	
10	10.0	254	
B 11 ¼	11.25	286	

Note: "B" designates a Base Tube section.

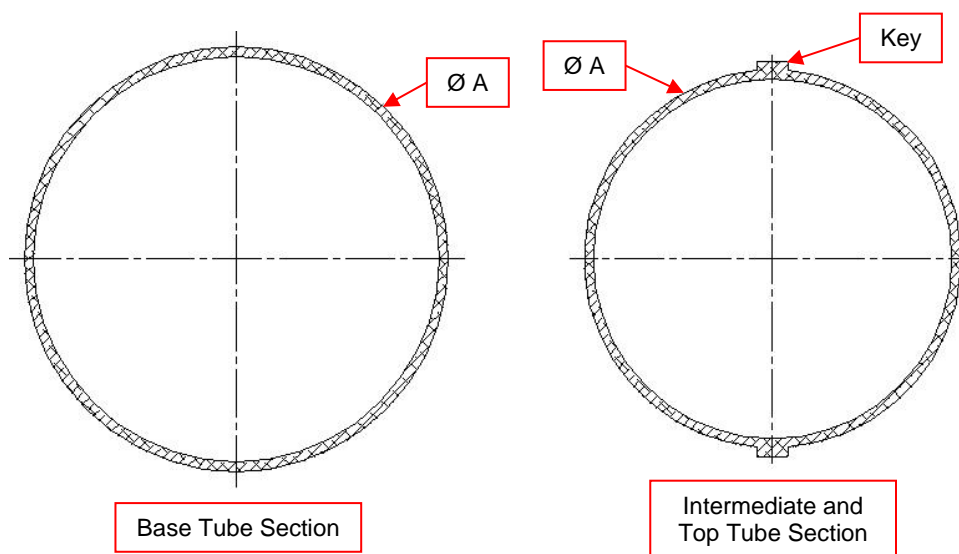

Figure 8-1 Tube Diameters

8.2.2 Collar Information

Table 8-2 Standard-Duty Collar Information

Tube	Non-Locking OD		Collar Bolts
	inch	mm	
2 ½	3.25	83	4
3	3.75	95	4
3 ½	4.25	108	6
4	4.75	121	6
4 ½	5.25	133	6
5	5.75	146	6

Table 8-3 Heavy-Duty Collar Information

Tube	Non-Locking OD		Collar Bolts	Tube	Locking OD		Collar Bolts	A	
	inch	mm			inch	mm		inch	mm
3 ¾	4.50	114	6	3 ¾	4.50	114	6	10.50	267
4 ½	5.20	132	6	4 ½	5.25	133	6	11.25	286
5 ¼	6.00	152	6	5 ¼	6.00	152	6	12.00	305
6	6.75	171	6	6	6.75	171	6	12.75	324
6 ¾	7.50	191	6	6 ¾	7.50	191	6	13.50	343
7 ½	8.25	210	8	7 ½	8.25	210	6	14.25	362
8 ¼	9.00	229	8	8 ¼	9.00	229	6	15.00	381
9	9.75	248	8	9	9.75	248	6	15.75	400

Table 8-4 Super-Heavy-Duty Collar Information

Tube	Non-Locking OD		Collar Bolts	Locking OD		Collar Bolts	A	
	inch	mm		inch	mm		inch	mm
4 ½	5.20	132	6	5.25	133	6	11.25	286
5 ¼	6.00	152	6	6.00	152	6	12.00	305
6	6.75	171	6	6.75	171	6	12.75	324
6 ¾	7.50	191	6	7.50	191	6	13.50	343
7 ½	8.25	210	8	8.25	210	6	14.25	362
8 ¼	9.00	229	8	9.00	229	6	15.00	381
9 ⅛	10.13	257	8	9.75	248	6	15.75	400
10	11.00	279	8	10.75	273	6	16.63	422
11 ¼	12.13	308	8	11.75	298	6	17.50	445

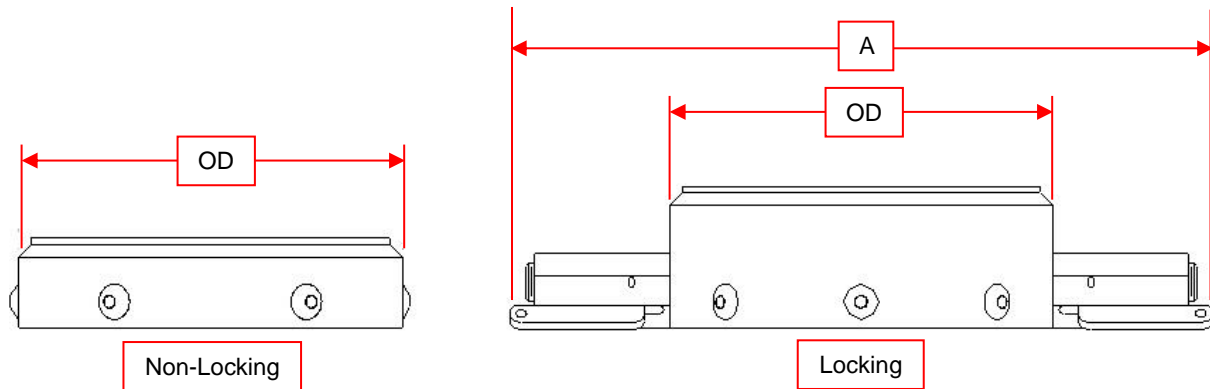

Figure 8-2 Collar Information

8.3 Drawings

Refer to the www.willburt.com for drawings of your Mast System.