

REVISION HISTORY				
ECN	REV	DESCRIPTION	DATE	BY/APPR
10272	00	INITIAL RELEASE	10/20/2010	CJM/
10341	A	TP-4602001 was 4022310	12/8/2010	CJM/
10428	B	ADDED DIMENSIONS; ADDED TABULATED BOM	2/15/2011	SMB\
10452	C	ADDED 720749041	4/13/2011	SMB\

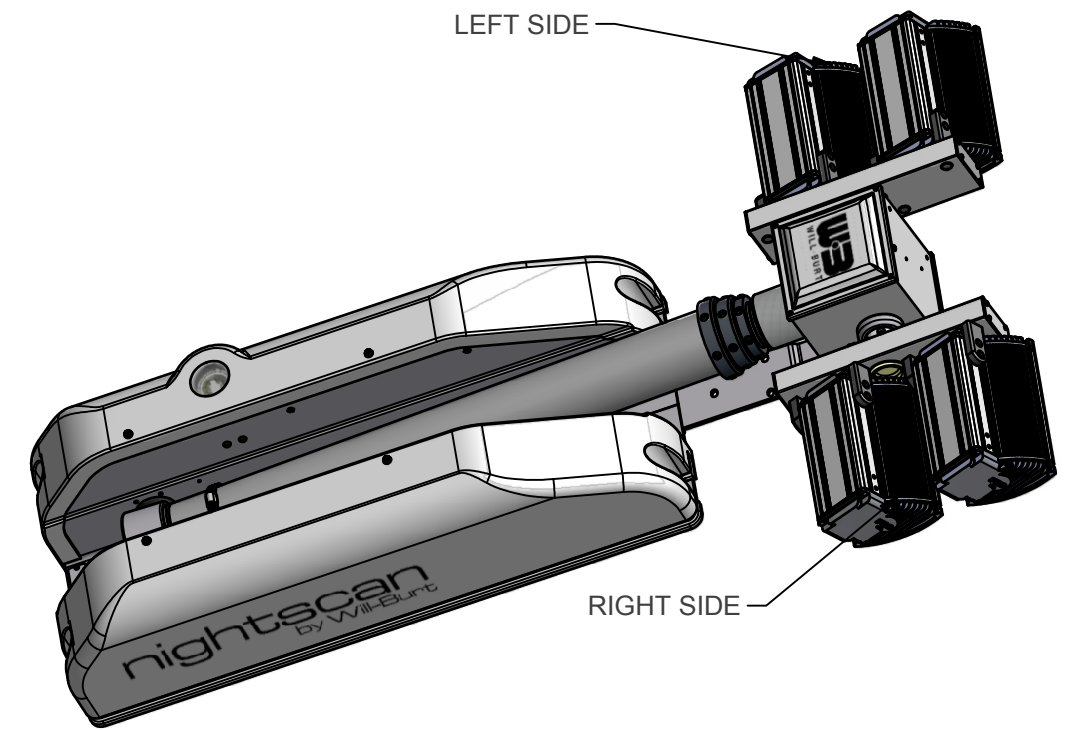
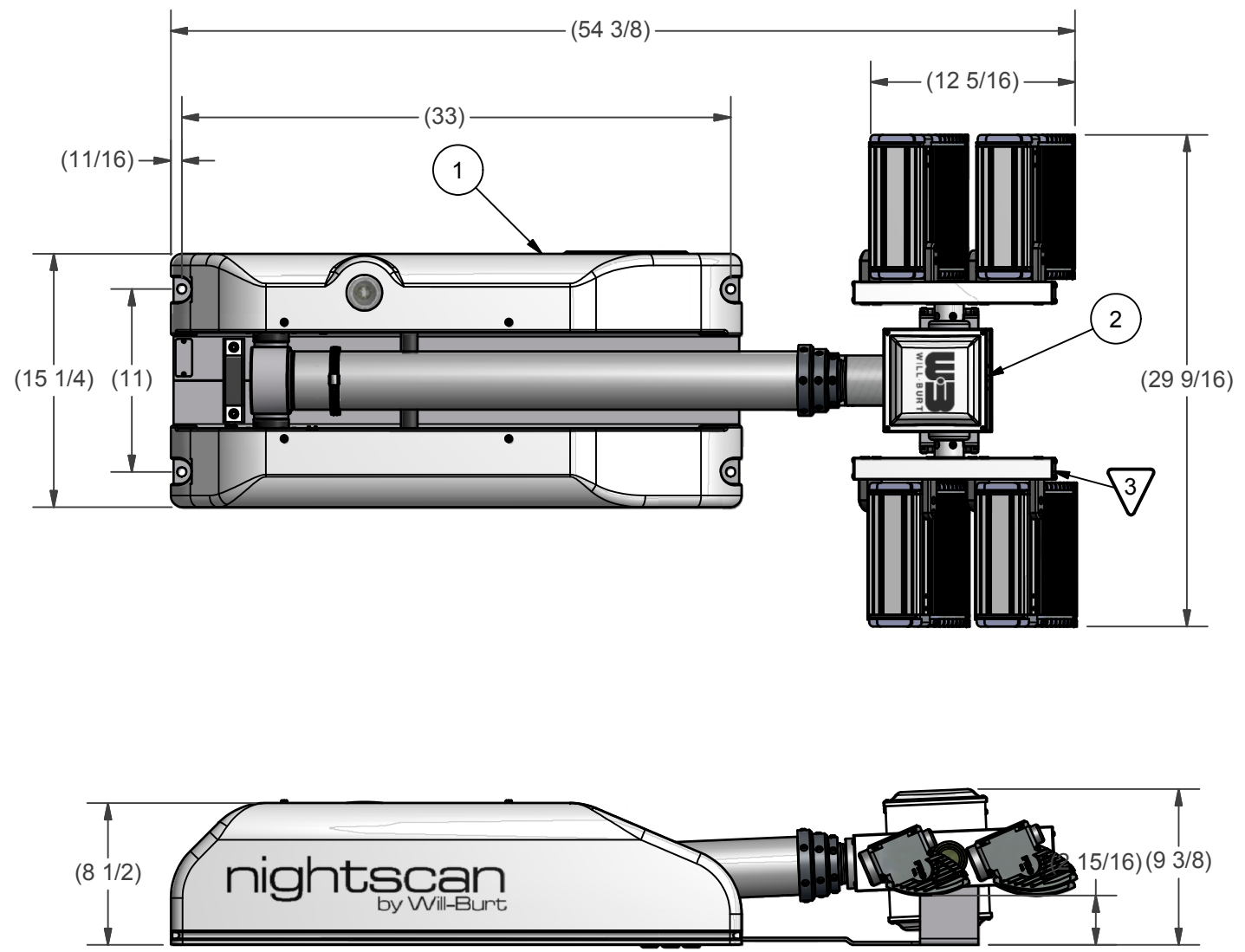

NOTES:

- 1 APPLY RTV #739 OR EQUAL TO ALL OPEN HOLES.
- 2 SEE WIRING DIAGRAM 46066 FOR ALL UNITS.
- 3 SET LIGHT BARS HOME POSITION PARALLEL TO BASE PLATE WHEN STOWED.

APPROX. WT: 106.45 lbmass
 THIRD ANGLE PROJECTION

UNLESS OTHERWISE SPECIFIED DIMENSIONS ARE IN INCHES.
 TOLERANCES ON DECIMALS ANGLES
 0 = ± 0.030 ± 1/2°
 00 = ± 0.010
 000 = ± 0.005
 FRACTIONAL ± 1/64"
 1. ALL INSIDE EDGES TO HAVE .005" TO .035" FILLETS.
 2. ALL OUTSIDE EDGES TO HAVE .005" TO .015" CHAMFER OR RADIUS.
 125° ON ALL MACHINED SURFACES

PROPRIETARY AND CONFIDENTIAL	
THE INFORMATION CONTAINED IN THIS DRAWING IS THE SOLE PROPERTY OF THE WILL-BURT COMPANY ANY REPRODUCTION IN PART OR WHOLE WITHOUT THE WRITTEN PERMISSION OF THE WILL-BURT COMPANY IS PROHIBITED.	
APPROVALS	DATE
DRAWN SMB	2/15/2011
CHECKED	

WILL-BURT AN EMPLOYEE OWNED COMPANY ORRVILLE, OH	
TITLE NS 2.3 4-LIGHT SHORT OPTIMUM KIT	
SIZE B	DWG NO 720762041
PN: SEE TABLE	REV C
SHEET 1 OF 2	

BOM			
ITEM	QTY	PART NUMBER	DESCRIPTION
2	1	4548301	NSC RCP, LIGHTS ONLY
3	1	SEE TABLE	LIGHT KIT
1	1	4522001	BASE ASSEMBLY, 7.5 CLR
4	1	4558901	NSC LABEL KIT (NOT SHOWN)
5	1	900600	MAST OIL (SHIP LOOSE)
6	1	TP-4602001	MANUAL, NS 1.8/2.3, CE, CD VERSION (NOT SHOWN)



ASSEMBLY NO	ITEM 2 PART NO	ITEM 2 DESCRIPTION
720762041	4574603	OPT 4 LIGHT, 3000W (4-750W 110VAC) WHT
720764041	4574609	OPT 4 LIGHT, 3000W (4-750W 220VAC) WHT
720766041	4574611	OPT 4 LIGHT, 2000W (4-500W 110VAC) WHT

APPROX. WT: 106.45 lbmass

THIRD ANGLE PROJECTION



UNLESS OTHERWISE SPECIFIED
DIMENSIONS ARE IN INCHES.

TOLERANCES ON DECIMALS ANGLES
 0 = ± 0.030 ± 1/2°
 .00 = ± 0.010
 .000 = ± 0.005

FRACTIONAL ± 1/64"

1. ALL INSIDE EDGES TO HAVE
.005" TO .035" FILLETS.
 2. ALL OUTSIDE EDGES TO HAVE
.005" TO .015" CHAMFER OR RADIUS.

$\sqrt[125]{}$ ON ALL MACHINED SURFACES

PROPRIETARY AND CONFIDENTIAL
 THE INFORMATION CONTAINED IN THIS
 DRAWING IS THE SOLE PROPERTY OF THE
 WILL-BURT COMPANY ANY REPRODUCTION
 IN PART OR WHOLE WITHOUT THE WRITTEN
 PERMISSION OF THE WILL-BURT COMPANY IS
 PROHIBITED.

WB AN EMPLOYEE OWNED COMPANY
 WILL-BURT ORRVILLE, OH

TITLE
**NS 2.3 4-LIGHT SHORT
 OPTIMUM KIT**

APPROVALS	DATE
DRAWN SMB	2/15/2011
CHECKED	

SIZE	DWG NO	REV
B	720762041	C
PN:	SEE TABLE	SHEET 2 OF 2