

4

3

2

1

ASSEMBLY NO	DESCRIPTION	ITEM-1 P/N	ITEM-2 P/N	ITEM-3 P/N	ITEM-4 P/N	ITEM-5 P/N
720749040	NS 2.3-6000-4 OPT-220V BLACK	4522002	4548302	4574602	NONE	4558903
720749041	NS 2.3-6000-4 OPT-220V WHITE	4522001	4548301	4574601	NONE	4558901
720749043	NS 2.3-6000-4 OPT-220V w/GRN STROBE	4522001	4548305	4574601	4481603	4558901
720749044	NS 2.3-6000-4 OPT-220V w/RED STRB	4522001	4548305	4574601	4481602	4558901
720763041	NS 2.3-4000-4 OPT-220V WHITE	4522001	4548301	4574607	NONE	4558901
720763043	NS 2.3-4000-4 OPT-110V w/AMBER STRB	4522001	4548305	4574618	4481601	4558901
720763044	NS 2.3-4000-4 OPT-220 w/RED STRB	4522001	4548305	4574607	4481602	4558901
720771041	NS 2.3-3600-4 OPT-220V WHITE	4522001	4548301	4574605	NONE	4558901
720771043	NS 2.3-3600-4 OPT. 220V w/BLUE STROBE	4522001	4548305	4574605	4481605	4558901
720771044	NS 2.3-6000-4 OPT-220V w/BLUE STROBE	4522001	4548305	4574601	4481605	4558901
720771045	NS 2.3-6000-4 OPT-220V w/AMBER STRB	4522001	4548305	4574601	4481601	4558901

REVISION HISTORY				
ECN	REV	DESCRIPTION	DATE	BY/APPR
11225	J	Added 720771045 Assembly	8/27/2012	RCC\
11555	K	Added 720763043 Assembly	4/3/2013	DAS\
11637	L	Added 720749040 Assembly	5/28/2013	RCC\
11721	M	Added 720763044 Assembly	7/31/2013	RCC



B

B

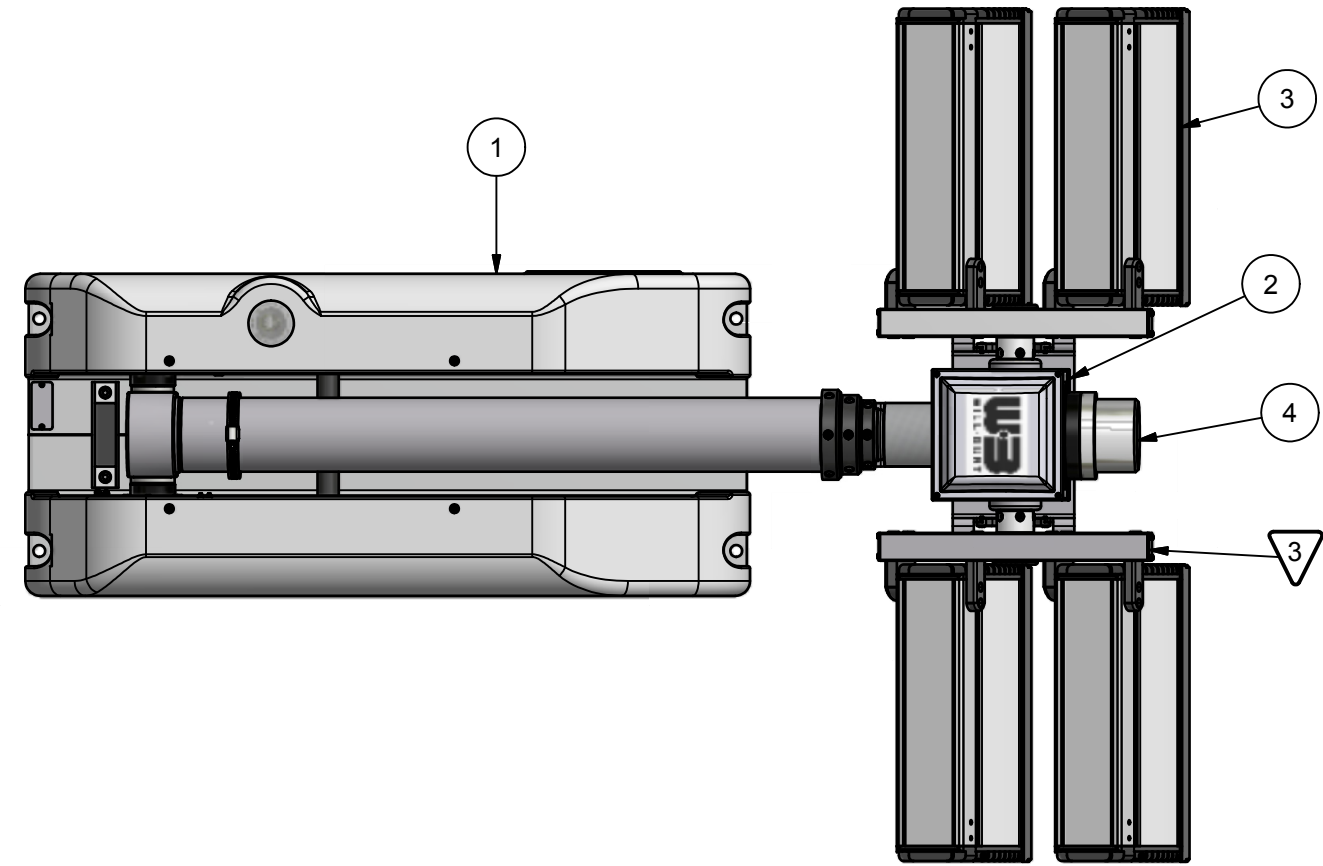

NOTES:

- 1 APPLY RTV #739 OR EQUAL TO ALL OPEN HOLES.
- 2 SEE WIRING DIAGRAM 46066 FOR ALL UNITS.
- 3 SET LIGHT BARS HOME POSITION PARALLEL TO BASE PLATE WHEN STOWED.

BOM			
ITEM	QTY	PART NUMBER	DESCRIPTION
1	1	SEE TABLE	BASE ASSEMBLY, 7.5 CLR
2	1	SEE TABLE	NSC RCP
3	1	SEE TABLE	LIGHT KIT
4	1	SEE TABLE	Light, Strobe Kit
5	1	SEE TABLE	NSC LABEL KIT (NOT SHOWN)
6	1	900600	MAST OIL (SHIP LOOSE)
7	1	TP-4602001	MANUAL, NS 1.8/2.3, CE, CD VERSION (NOT SHOWN)

A

A

**UNLESS OTHERWISE SPECIFIED DIMENSIONS ARE IN INCHES.**  
 TOLERANCES ON DECIMALS ANGLES  
 0 = ± 0.030 ± 1/2°  
 00 = ± 0.010  
 000 = ± 0.005  
 FRACTIONAL ± 1/64"  
 1. ALL INSIDE EDGES TO HAVE .005" TO .035" FILLETS.  
 2. ALL OUTSIDE EDGES TO HAVE .005" TO .015" CHAMFER OR RADIUS.  
 125° ON ALL MACHINED SURFACES

APPROX. WT:110.9 lbmass

THIRD ANGLE PROJECTION



**PROPRIETARY AND CONFIDENTIAL**  
 THE INFORMATION CONTAINED IN THIS DRAWING IS THE SOLE PROPERTY OF THE WILL-BURT COMPANY ANY REPRODUCTION IN PART OR WHOLE WITHOUT THE WRITTEN PERMISSION OF THE WILL-BURT COMPANY IS PROHIBITED.



TITLE  
**NS 2.3 4-LIGHT LONG OPTIMUM KIT**

APPROVALS	DATE
DRAWN SMB	2/15/2011
CHECKED	

SIZE	DWG NO	REV
B	720749041	M
PN:	SEE ABOVE	SHEET 1 OF 2

4

3

2

1

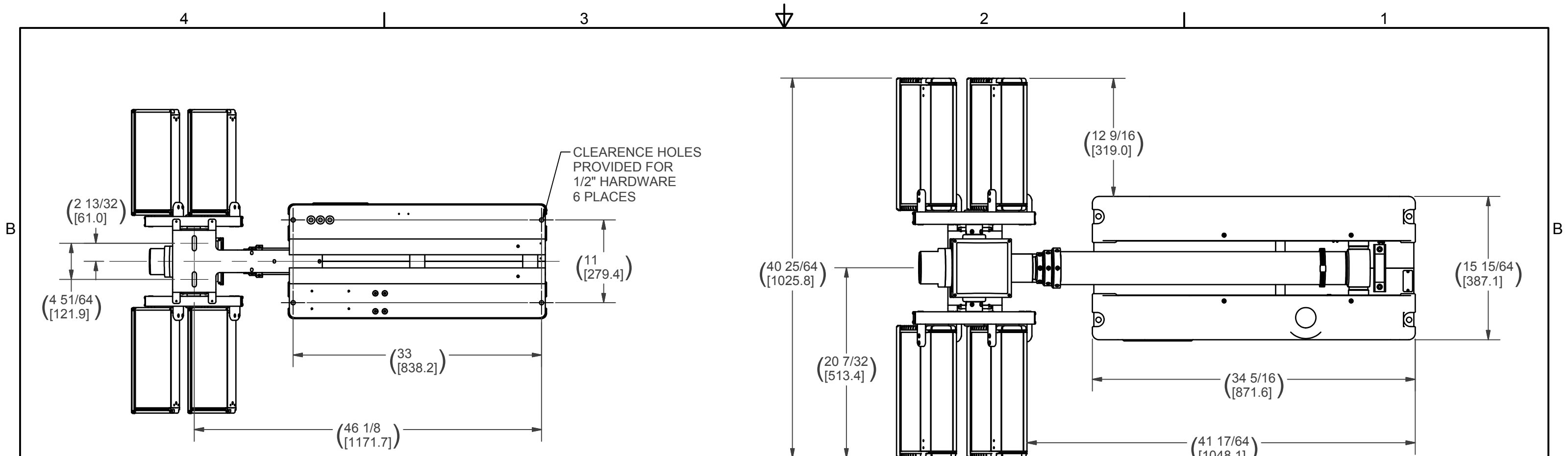

MOUNTING (BOLT PATTERN)  
(BOTTOM VIEW)

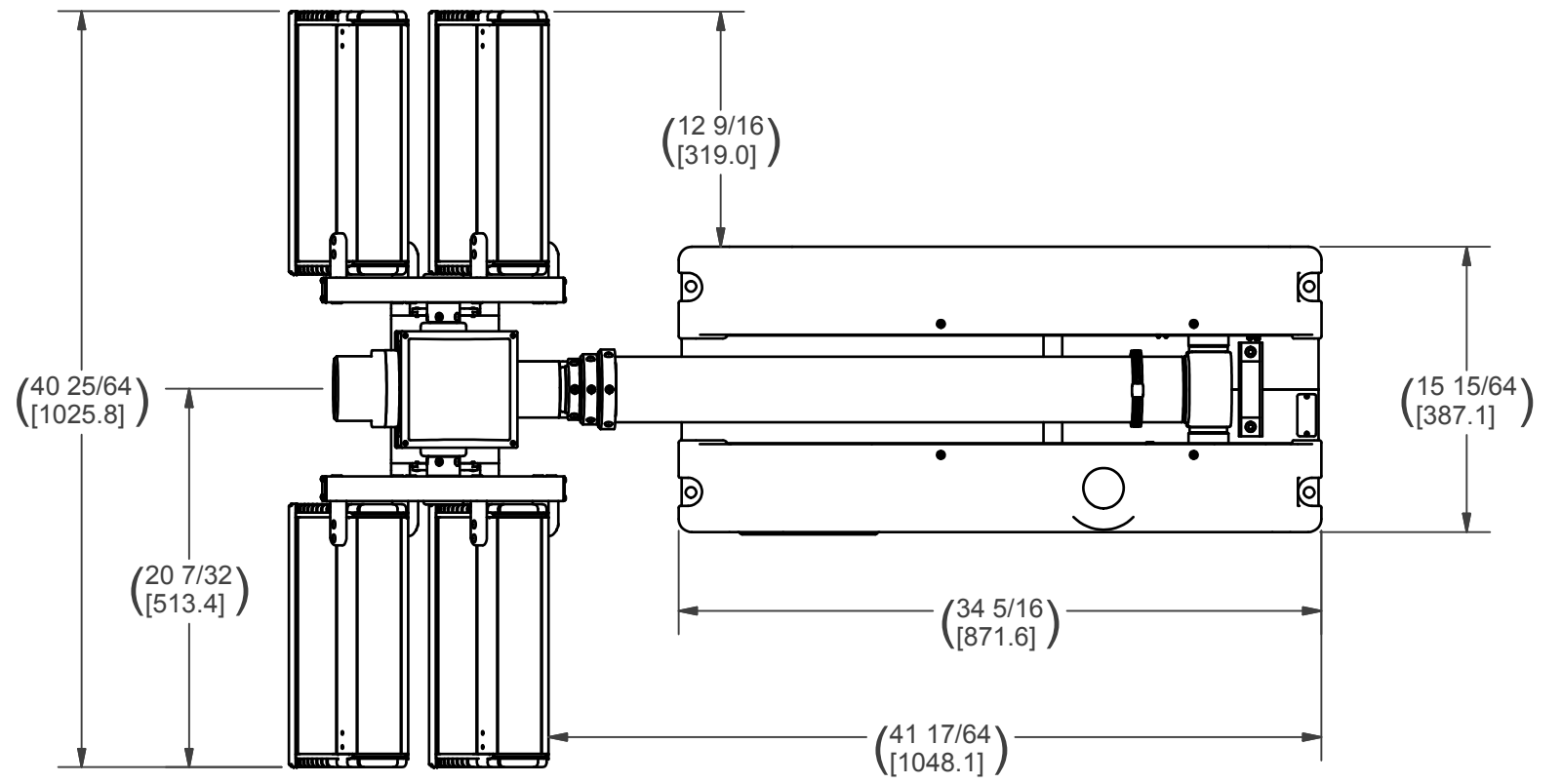
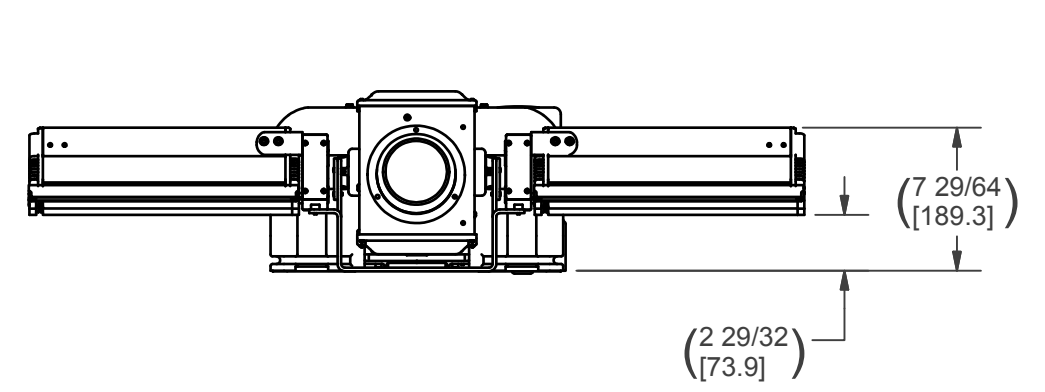

ALL SPECIFICATIONS SUBJECT TO CHANGE WITHOUT NOTICE.

NOTES:  
PRIMARY DIMENSIONS INCHES  
SECONDARY DIMENSIONS MILLIMETERS.

APPROX. WT:110.9 lbmass

THIRD ANGLE PROJECTION



**UNLESS OTHERWISE SPECIFIED  
DIMENSIONS ARE IN INCHES.**  
TOLERANCES ON DECIMALS ANGLES  
0 = ± 0.030 ± 1/2°  
.00 = ± 0.010  
.000 = ± 0.005  
FRACTIONAL ± 1/64"  
1. ALL INSIDE EDGES TO HAVE  
.005" TO .035" FILLETS.  
2. ALL OUTSIDE EDGES TO HAVE  
.005" TO .015" CHAMFER OR RADIUS.  
125√ ON ALL MACHINED SURFACES

**PROPRIETARY AND CONFIDENTIAL**  
THE INFORMATION CONTAINED IN THIS  
DRAWING IS THE SOLE PROPERTY OF THE  
WILL-BURT COMPANY ANY  
REPRODUCTION IN PART OR WHOLE  
WITHOUT THE WRITTEN PERMISSION OF  
THE WILL-BURT COMPANY IS PROHIBITED.

**WB** AN EMPLOYEE OWNED COMPANY  
WILL-BURT ORRVILLE, OH

TITLE  
**NS 2.3 4-LIGHT LONG  
OPTIMUM KIT**

APPROVALS	DATE
DRAWN SMB	2/15/2011
CHECKED	

SIZE B	DWG NO 720749041	REV M
PN: SEE ABOVE	SHEET 2 OF 2	