

A1(420x297)

VXQF 405-4(Rev.1)

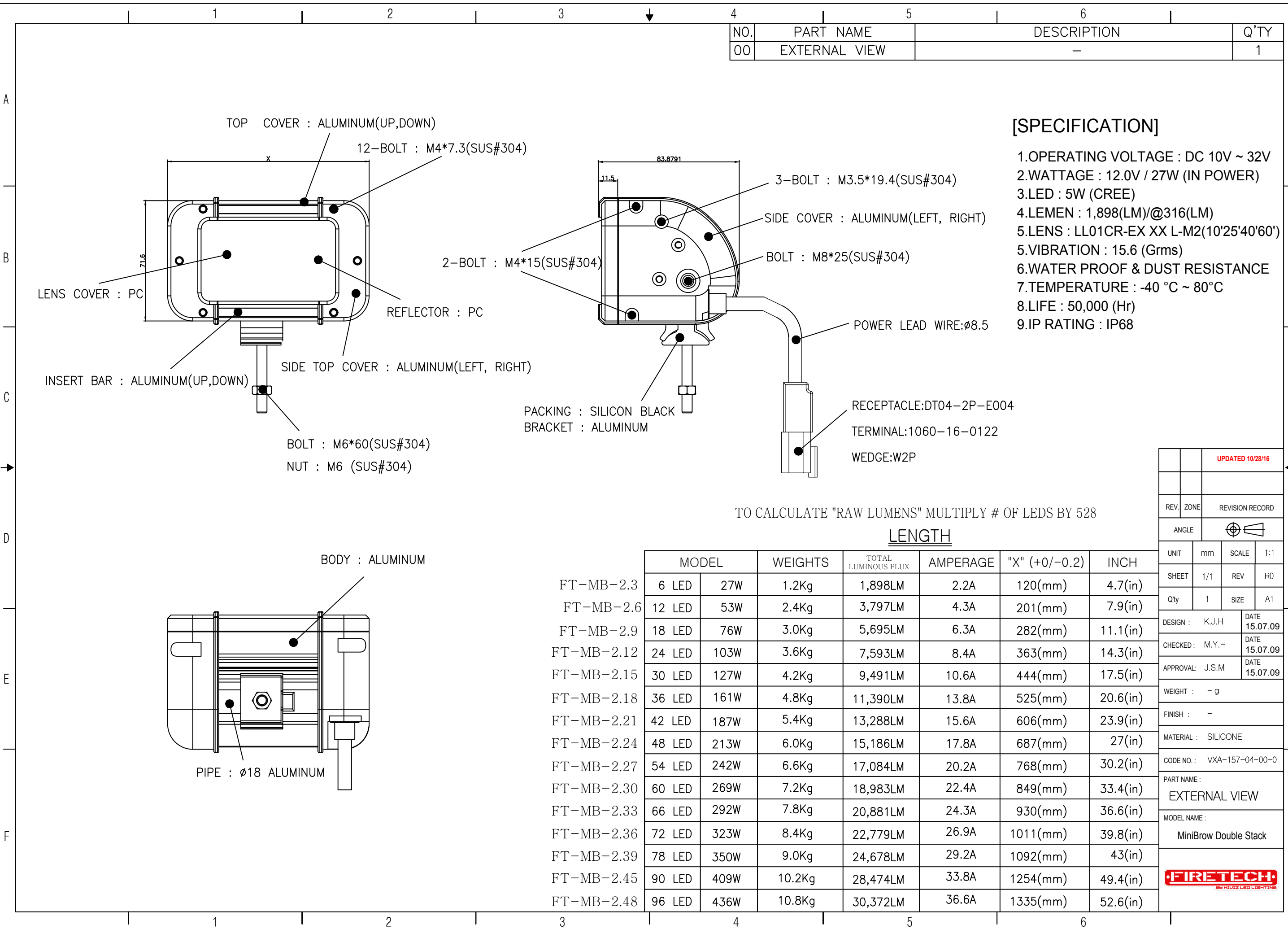

NO.	PART NAME	DESCRIPTION	Q'TY
00	EXTERNAL VIEW	-	1

[SPECIFICATION]

1. OPERATING VOLTAGE : DC 10V ~ 32V
2. WATTAGE : 12.0V / 27W (IN POWER)
3. LED : 5W (CREE)
4. LUMEN : 1,898(LM)/@316(LM)
5. LENS : LL01CR-EX XX L-M2(10'25'40'60')
5. VIBRATION : 15.6 (Grms)
6. WATER PROOF & DUST RESISTANCE
7. TEMPERATURE : -40 °C ~ 80°C
8. LIFE : 50,000 (Hr)
9. IP RATING : IP68

TO CALCULATE "RAW LUMENS" MULTIPLY # OF LEDS BY 528

LENGTH

MODEL	WEIGHTS	TOTAL LUMINOUS FLUX	AMPERAGE	"X" (+0/-0.2)	INCH
FT-MB-2.3	6 LED 27W 1.2Kg	1,898LM	2.2A	120(mm)	4.7(in)
FT-MB-2.6	12 LED 53W 2.4Kg	3,797LM	4.3A	201(mm)	7.9(in)
FT-MB-2.9	18 LED 76W 3.0Kg	5,695LM	6.3A	282(mm)	11.1(in)
FT-MB-2.12	24 LED 103W 3.6Kg	7,593LM	8.4A	363(mm)	14.3(in)
FT-MB-2.15	30 LED 127W 4.2Kg	9,491LM	10.6A	444(mm)	17.5(in)
FT-MB-2.18	36 LED 161W 4.8Kg	11,390LM	13.8A	525(mm)	20.6(in)
FT-MB-2.21	42 LED 187W 5.4Kg	13,288LM	15.6A	606(mm)	23.9(in)
FT-MB-2.24	48 LED 213W 6.0Kg	15,186LM	17.8A	687(mm)	27(in)
FT-MB-2.27	54 LED 242W 6.6Kg	17,084LM	20.2A	768(mm)	30.2(in)
FT-MB-2.30	60 LED 269W 7.2Kg	18,983LM	22.4A	849(mm)	33.4(in)
FT-MB-2.33	66 LED 292W 7.8Kg	20,881LM	24.3A	930(mm)	36.6(in)
FT-MB-2.36	72 LED 323W 8.4Kg	22,779LM	26.9A	1011(mm)	39.8(in)
FT-MB-2.39	78 LED 350W 9.0Kg	24,678LM	29.2A	1092(mm)	43(in)
FT-MB-2.45	90 LED 409W 10.2Kg	28,474LM	33.8A	1254(mm)	49.4(in)
FT-MB-2.48	96 LED 436W 10.8Kg	30,372LM	36.6A	1335(mm)	52.6(in)

UPDATED 10/28/16			
REV.	ZONE	REVISION RECORD	
ANGLE			
UNIT	mm	SCALE	1:1
SHEET	1/1	REV	R0
Q'ty	1	SIZE	A1
DESIGN :	K.J.H	DATE	15.07.09
CHECKED :	M.Y.H	DATE	15.07.09
APPROVAL :	J.S.M	DATE	15.07.09
WEIGHT :	- g		
FINISH :	-		
MATERIAL :	SILICONE		
CODE NO. :	VXA-157-04-00-0		
PART NAME :	EXTERNAL VIEW		
MODEL NAME :	MiniBrow Double Stack		