



WILL-BURT

**YACHT MAST
OPERATOR'S MANUAL**



The Will-Burt Company
401 Collins Blvd
Orrville, OH 44667, U.S.A.

Phone: +1 330 684 4000
E-Mail: info@willburt.com
Website: www.willburt.com

TP-5921301-00, February 2023
© 2023 The Will-Burt Company
Original Instructions

Authorized Representative:
Will-Burt Germany GmbH & Co. KG
Fischergasse 25
D-91344 Waischenfeld, Germany

Yacht Mast Warranty

Will-Burt warrants its Yacht Masts to be free from defects in material and workmanship for a period of two (2) years, with such time period running from the date of shipment by Will-Burt. Will-Burt shall not be responsible for any damage resulting to or caused by its products by reason of failure to properly install, maintain or store the product; use of the product in a manner inconsistent with its design; unauthorized service, alteration of products, neglect, abuse, accident, or acts of God. This warranty does not extend to any component parts not manufactured by Will-Burt; provided, however, Will-Burt's warranty herein shall not limit any warranties by manufacturers of component parts which extend to the buyer.

THE FOREGOING WARRANTY IS IN LIEU OF ALL OTHER WARRANTIES, AND NO REPRESENTATIONS, GUARANTEES OR WARRANTIES, EXPRESS OR IMPLIED, INCLUDING BUT NOT LIMITED TO, A WARRANTY OF MERCHANTABILITY, FITNESS FOR A PARTICULAR PURPOSE, OR NON-INFRINGEMENT ARE MADE BY WILL-BURT IN CONNECTION WITH THE MANUFACTURE OR SALE OF ITS PRODUCTS. NO EMPLOYEE, DISTRIBUTOR, OR REPRESENTATIVE IS AUTHORIZED TO CHANGE THIS WARRANTY IN ANY WAY OR GRANT ANY OTHER WARRANTY ON BEHALF OF WILL-BURT.

Claims for defects in material and workmanship shall be made in writing to Will-Burt within thirty (30) days of the discovery of defect. Failure to provide notice as required hereby shall be conclusive evidence that the product was in conformity with the warranty, and Will-Burt shall be released from any and all liability relating to the product. Will-Burt may either send a service representative or have the product returned to its factory at Buyer's expense for inspection. If judged by Will-Burt to be defective in material or workmanship, the product will be replaced or repaired at the option of Will-Burt, free from all charges except authorized transportation.

THE REMEDIES OF BUYER SET FORTH HEREIN ARE EXCLUSIVE AND ARE IN LIEU OF ALL OTHER REMEDIES. THE LIABILITY OF WILL-BURT WHETHER IN CONTRACT, TORT, UNDER ANY WARRANTY, OR OTHERWISE, SHALL NOT EXTEND BEYOND ITS OBLIGATION TO REPAIR OR REPLACE, AT ITS OPTION, ANY PRODUCT OR PART FOUND BY WILL-BURT TO BE DEFECTIVE IN MATERIAL OR WORKMANSHIP. WILL-BURT SHALL NOT BE LIABLE FOR COST OF INSTALLATION AND/OR REMOVAL, OR BE RESPONSIBLE FOR DIRECT, INDIRECT, SPECIAL OR CONSEQUENTIAL DAMAGES OF ANY NATURE.

Document History

Document	Dates	Remarks
TP-5921301-00	Feb. 2023	Initial Release

Table of Contents

Section 1 Safety Summary	v
1.1 Signal Word Definitions	v
1.2 Safety Instructions	v
1.3 Symbols	xii
Section 2 Introduction	2-1
2.1 Safety Precautions	2-1
2.2 Intended Use	2-1
2.3 Definitions	2-1
2.4 Mast Component Descriptions	2-2
Section 3 Technical Data	3-1
Section 4 Installation	4-1
4.1 Pre-Installation Check	4-1
4.2 Recommended Installation Tools	4-1
4.3 Unpacking and Handling	4-2
4.4 Select a Suitable Mounting Location	4-3
4.5 Begin Installation	4-4
4.6 Lower Mast Through the Internal Mounting Kit	4-5
4.7 Attach the Base Plate to the Mast	4-5
4.8 Position the Mast	4-5
4.9 Secure the Base Plate to the Mounting Surface	4-6
4.10 Weep Hole Drain Kit Installation	4-6
4.11 Pneumatic System Installation	4-8
4.11.1 General Concepts	4-8
4.11.2 General Procedures	4-9
4.12 Test the Installation	4-11
4.13 Install the Payload	4-12
Section 5 Operation	5-1
5.1 Pre-Operation Check	5-1
5.2 Operation Equipment	5-2
5.3 Mast Operation	5-2
5.3.1 Non-Locking Mast Operation	5-2
5.3.1.1 Extending the Mast	5-2
5.3.1.2 Lowering the Mast	5-3
5.3.2 Locking Mast Operation	5-3
5.3.2.1 Extending the Mast	5-3
5.3.2.2 Lowering the Mast	5-6
Section 6 Transportation	6-1
6.1 General Transportation	6-1
6.2 Shipping	6-2
Section 7 Maintenance, Adjustments and Disposal	7-1
7.1 Pre-Maintenance Check	7-1
7.2 Maintenance Equipment	7-2

7.3 Cleaning and Lubrication	7-3
7.4 Corrective Maintenance	7-4
7.4.1 Replace Seals	7-5
7.4.2 Replace Collar Bearing Strips	7-7
7.4.3 Replace Wear Rings	7-8
7.4.4 Replace Internal Bumpers	7-9
7.4.5 Replace External Bumpers	7-10
7.5 Long-Term Storage	7-11
7.6 System Disposal	7-11
Section 8 Troubleshooting	8-1

Table of Figures

Figure 2-1 Telescoping Masts (Not to Scale)	2-2
Figure 2-2 Non-Rotatable Base Plate	2-3
Figure 2-3 Internal Mount Bracket	2-4
Figure 4-1 Shipping Crate	4-2
Figure 4-2 Hoist the Mast (Pneumatic Mast Shown)	4-2
Figure 4-3 Roof Line Location (Locking Mast Shown)	4-3
Figure 4-4 Internal Mounting Kit	4-4
Figure 4-5 Drain Kit (P/N: 902982)	4-7
Figure 4-6 Weep Hole Drain Kit	4-7
Figure 4-7 General Pneumatic System Layout	4-9
Figure 4-8 Pneumatic System Installation	4-10
Figure 5-1 Sample of Laying Out Guy Lines (Mast with 4 Way 5 Level Guying Shown)	5-4
Figure 5-2 Locked Collar View	5-4
Figure 5-3 Vertically Align the Mast (Sample Shown with 6 Level Guying)	5-5
Figure 5-4 Locked Collar View	5-6
Figure 7-1 Seal Replacement	7-6
Figure 7-2 Replace Collar Bearing Strips	7-7
Figure 7-3 Replace Wear Rings	7-8
Figure 7-4 Replace Internal Bumpers	7-9
Figure 7-5 Replace External Bumpers	7-10

Table of Tables

Table 3-1 Locking Yacht Masts	3-1
Table 3-2 Non-Locking Yacht Masts	3-2
Table 4-1 Tools and Materials Required for Installation	4-1
Table 5-1 Equipment Recommended for Operation	5-2
Table 7-1 Equipment Recommended for Maintenance	7-2
Table 8-1 Troubleshooting	8-1

Section 1 Safety Summary

This section describes safety instructions for the Yacht Mast that personnel must understand and apply throughout all product activities such as transportation, handling, installation, operation, maintenance, storage, disposal and troubleshooting. Read and understand this entire document, and contact The Will-Burt Company with any questions, before performing any procedure outlined in this document. Keep this document during the entire duration of use of the device. Pass this document along to trained and qualified end users.

1.1 Signal Word Definitions

The following signal words and definitions are used to indicate hazardous situations:

DANGER

DANGER indicates an imminently hazardous situation that, if not avoided, will result in death or serious injury.

WARNING

WARNING indicates a potentially hazardous situation that, if not avoided, could result in death or serious injury.

CAUTION

CAUTION indicates a potentially hazardous situation that, if not avoided, may result in minor or moderate injury. It is also used to alert against unsafe practices.

1.2 Safety Instructions

DANGER

Electrocution Hazard! Contact with high voltage will result in death or serious injury. Observe general safety precautions for handling equipment using high voltage. Do not locate or operate mast near electrical lines, cables or other unwanted sources of electricity. Allow sufficient clearance on all sides of mast to allow for side sway. Do not operate mast during an electrical storm. Be certain electrical cables are undamaged and properly terminated. Do not touch live wires. Follow OSHA or other national safety regulations when working near energized power lines. Personnel working with or near high voltages should be familiar with methods of resuscitation.

DANGER

Disconnect Power for Service! Always disconnect all power sources following proper lock-out tag-out procedures before performing service, repair or test operations. Remove the tethered hand held control where applicable for added protection during maintenance.

⚠ DANGER

Mast Tip Over Hazard! Mast tip over could result in death or serious injury. Before operation, be certain mounting structure is capable of resisting forces generated from all loading and environmental conditions, including, but not limited to, mast size and weight, payload and cable size and weight, payload sail area, wind speed, guy line arrangement, support bracket or roof line location, and base plate assembly. Do not operate in wind speed conditions exceeding the maximum rated wind speed. Do not operate on slopes exceeding the maximum deployment angle. Do not install a payload that exceeds the maximum payload lifting capacity of mast. Do not install a payload with the center of gravity offset from mast centerline exceeding the maximum allowed offset. Stand clear of mast and mast payload during operation. Be certain mast is level and secure before and during installation, operation, and maintenance.

⚠ DANGER

Falling Objects from Mast Hazard! Wear a protective hard hat when working on mast or situated near mast operating area while mast is extending, retracting or deployed in any position above the nested position. Improperly secured payload or mast components, ice formations, etc. could be dislodged from mast and fall. Be sure the payload is properly installed and secured.

⚠ DANGER

Relocation/Driving Hazard! Do not relocate the system during operation or while mast is extended to any height above the nested position or powered up. Do not move vehicle until mast has been securely nested and isolated from power. Power-up and operate mast only if the vehicle is stationary and securely parked with the parking brake properly applied. Do not put mast in service or operate without the vehicle interlock warning circuit or magnetic warning kit installed to provide confirmation mast is nested prior to moving the vehicle. Contact The Will-Burt Company Engineering for special on-the-move situations for military only use on specialized products.

⚠ DANGER

Burst Hazard! For pneumatically operated masts, do not operate without the over-pressure safety valve installed. Keep personnel clear of safety valve exhaust direction. Do not exceed the maximum rated pressure of mast. If the mast air pressure is not fully discharged prior to removing air hoses, a rapid release of air pressure will occur requiring hearing and eye protection.

⚠ WARNING

Payload Lifting Hazard - Intended Use! The mast is intended to lift a specific payload for lighting, surveillance or communication use only. Any other use without written consent is prohibited and could cause death or serious injury. Do not use mast to lift personnel. Do not exceed specified payload capacity. Large payload wind sail areas can reduce payload capacity. Consult The Will-Burt Company engineering.

⚠ WARNING

Read Operating Instructions! Read and observe the operating instructions. Non-observance of the instructions, operation which is not in accordance with use as prescribed in the instructions, wrong installation or incorrect handling can seriously affect the safety of operators and machinery. Adhere to the safety instructions when carrying out any activity relating to the Pneumatic Mast.

⚠ WARNING

Trained Personnel Only! This product is intended for use by trained professionals only. It is not intended for general use by the public or untrained personnel. Handling, installation, operation and maintenance to be performed by trained and authorized personnel only. Only a properly trained and qualified certified electrician should perform electric installations and service.

⚠ WARNING

Erratic Mast Operation Impact Hazard! The mast should operate smoothly during extension and retraction. If erratic mast motion is observed during extension or retraction that results in impact loading between the tube and the tube collar (mechanical travel stop), cease use of the mast and contact The Will-Burt Company service department. Repeated operation with impact loading can damage tubes and lead to mast separation.

⚠ WARNING

Over-current Protection! Over-current protection or power switching by the installer on mast incoming power supply as specified in this document should be a type suitable to allow lock-out tag-out procedures for power disconnect.

⚠ WARNING

Safety Instruction - Explosion! For outdoor use only. Do not use in explosive areas or areas that have been classified as hazardous as defined in Article 500 of the National Electric Code or equivalent national standards. Do not use in the presence of flammable gases or liquids such as paint, gasoline or solvents. Do not use in areas of limited ventilation or where high ambient temperatures are present.

⚠ WARNING

Safety Equipment (PPE)! Proper personal protective equipment (PPE) like hard hats, gloves, and safety shoes shall be properly worn while working on mast or near the deployment area of mast. In addition, eye protection shall be worn during maintenance procedures. Follow national PPE guidelines in your area of operation.

⚠ WARNING

Pinch Point Hazard! Keep clear of all moving parts like mast collars nesting. Be sure to stay clear of system during operation. Moving parts can crush and cut resulting in serious injury. The mast shall be mounted out of reach of the operator during operation.

⚠ WARNING

Crush Hazard - Mast Failure! Do not stand directly beneath mast or its payload. Be certain the payload is properly installed and secured.

⚠ WARNING

Entanglement Hazard! Tangled cables can cause equipment damage. Ensure payload cables, Nycoil®, trip lines, guy lines or other cables are not tangled and are free to pay out as mast is deployed. Cables that get tangled or snagged on mast or other objects can cause mast tubes to lurch upward suddenly when the cable is freed. This can cause damage to mast and lead to mast separation if repeatedly allowed to continue.

⚠ WARNING

Health and Safety Hazard while Cleaning! Solvent used to clean parts is potentially dangerous. Avoid inhalation of fumes and prolonged contact to skin.

⚠ WARNING

Fire Hazard Solvent! Cleaning solvent, used for maintenance, is flammable and can be explosive. Do not smoke near solvent. Use cleaning solvent in a well-ventilated area. Keep cleaning solvent away from ignition sources. Always store cleaning solvent in the proper marked container and in a proper location.

⚠ WARNING

Bright Light Radiation Hazard! For systems equipped with scene lighting or look-up lights, do not look directly into lights when they are illuminated. Temporary impairment or permanent vision damage could occur.

⚠ WARNING

Personnel Freezing/Burn Hazard! If the system is equipped with lights, make sure the lights are completely cool before attempting to clean the lens, replace bulbs or perform maintenance. Wear gloves to protect from contact with exposed metal that may be at extremes of hot and cold temperatures from sun or cold outdoor exposure.

⚠ WARNING

Mast Extension Hazard - Obstruction! Extending mast into obstructions could result in death or serious injury and could render mast inoperable and partially extended. Before applying power and operating mast, be certain there is sufficient clearance above and to all sides of the expected location of the fully extended mast and payload. Keep all persons clear of mast and mast extension. Do not lean directly over mast. Locate the operator station such that the operator has a clear view of the operating space of mast and payload prior to deployment to avoid contact with overhead objects.

⚠ WARNING

Manual Retraction! For powered masts, make sure all power sources have been disconnected from the system prior to manually lowering mast to avoid unexpected start-up motion and/or damage to mast.

⚠ WARNING

Mast Lifting/Handling! Use extreme caution while lifting mast System and when mast System is suspended to avoid injury and equipment damage. Be certain mast is properly secured using at least two sling points at the center of gravity label. All operators should be aware of and follow the applicable local, regional, and national standards and codes of practice for slinging and transporting equipment. Never lift Mast System over people. Ensure lifting equipment including, but not limited to, lifting straps and hoist, are capable of handling the forces generated from lifting the system. Observe manufacturer instructions on lifting equipment.

⚠ WARNING

Remove Payload! For mast systems shipped with no payload (customer installed payloads), remove payload before performing maintenance on mast system. The Will-Burt Company installed devices can remain installed.

⚠ WARNING

Equipment Damage - Submerged! Do not submerge mast in liquid or operate the vehicle in a fording situation that would result in a submerged mast.

⚠ WARNING

Safety Instruction – Keep Clear! Keep personnel clear of the system during operation.

⚠ WARNING

Safety Instruction - Potential Air Contaminants! If internally mounted in a vehicle, air from mast and any accumulated water will discharge into the vehicle. Install appropriate drainage and venting.

⚠ WARNING

Fastener Vibration Hazard! Mast system and payload mounting hardware must include proper means to resist vibration loosening such as thread-locking compound, locking hardware, or equivalent. Use specified assembly torques appropriate for the fastener size.

⚠ CAUTION

Frozen Water Hazard! Water freezing inside mast or air fittings may render mast inoperable and cause major equipment damage such as tube deformation. Ensure water is free to exit at the base of mast. Open drain cock when mast is not in operation. The drain cock shall be installed at the lowest position in the pneumatic system. If mounted internally in a vehicle or structure, direct the draining water to a suitable location. Cover locking masts when not in use to limit water ingress. Non-locking masts stored outdoors should be covered if possible. A cover is available from The Will-Burt Company.

⚠ CAUTION

Safety Instruction - Guy Anchors! For masts using Guy Lines, verify the Guy Anchor point strength is adequate to support the Guy Line forces.

⚠ CAUTION

Lubrication! Do not lubricate the exterior of mast moving tubes. The lubricant will attract dust and other environmental contaminants into mast.

⚠ CAUTION

Equipment Damage - Forces! Before unloading the system, be certain the unloading region is capable of resisting forces generated from unloading the system including but not limited to system weight. Ensure the unloading region is level and has sufficient room and strength to hold the system. If the unloading region is incapable of meeting the requirements of the system, damage to the system and/or unloading region could occur.

⚠ CAUTION

Equipment Damage - Support Bracket! For masts using an upper support bracket, do not over-tighten mast support bracket. Over-tightening may damage the Base Tube causing mast tubes to stick.

⚠ CAUTION

Mast and Payload Access! The operator must provide safe means to access mast and payload during installation, removal and maintenance.

⚠ CAUTION

Tripping Hazard! Cables, trip lines, guy lines and guy anchors can be hard to see during and after installation. Any equipment posing trip hazards should be clearly marked.

⚠ CAUTION

Pressurized Device Hazard! Mast disassembly prior to depressurization may release pressurized air jet. Completely lower the mast, depressurize and shut down power before disassembly.

⚠ CAUTION

Safety Instruction – Roof Access! If mast will be mounted to a vehicle, user must provide safe means to access the roof of the vehicle during installation and maintenance.

⚠ CAUTION

Safety Instruction – Control Valve! Improper positioning and operation of Control Valve can result in moderate injury or equipment damage. Control valve must be mounted in a location such that the operator has full view of the mast, but does not make contact with the mast during operation. Use only a Hold-To-Run type control valve.

⚠ CAUTION

Lifting Hazard! Manually lifting over 55 lb. (25 kg) is prohibited. In the UK, all lifting equipment must be thoroughly examined annually by a competent person according to the Lifting Operations and Lift Equipment Regulations 1998. Equivalent regulations exist in other EU states.

⚠ CAUTION

Safety Instruction – Installation! At all times while using pipe and hose during installation, recognize that:

- Pipe and hose should be routed, mounted and restrained to protect from damage
- Do not use secondhand piping for installation
- Do not bend air pipe and hose at a radius less than specified by the manufacturer
- Pipes should be marked to avoid hazards from incorrect connection
- The exhaust should be fitted with a silencer and be directed away from personnel
- When routing piping, install in such a way as to minimize torsion on the joints
- Mounting air pipe and hose shall be accomplished only by the use of tools to prevent readily disconnecting air pipe and hose from mast.

⚠ CAUTION

Safety Instruction – Follow Procedure! Failure to follow drain kit installation instructions could damage the mast and render the mast inoperable. Read and understand the installation instructions before installing the drain kit.

1.3 Symbols

The following are symbols that are used with the system and their meaning. Contact The Will-Burt Company with any questions before performing any procedure outlined in this manual.



This symbol indicates an electrocution hazard or hazardous voltage hazard. There is DC voltage present inside the mast and control box. Do not operate mast near electrical lines or during lightning events. Contact with high voltage will result in death or serious injury.



This symbol indicates a pinch point hazard. Keep fingers and hands clear of moving parts.



This symbol indicates a tip-over hazard. The mast must be properly supported during transport, installation, maintenance and operation. System tip-over could result in death or serious injury.



This symbol indicates a general warning. In this unit, this symbol indicates a frozen water hazard. Do not block the mast drain port at the base of the unit. Water must be permitted to exit the mast to avoid ice damage to the mast.



This symbol is used to remind users to read and understand the operator's manual before operating the Mast System. Failure to follow operating instructions could result in death or serious injury. Read and understand operator's manual before operating or installing the mast system.



This symbol indicates a hard hat is required when working under the mast operating area. Failure to wear a hard hat could result in death or serious injury.



This symbol indicates an electrical ground connection point.



This symbol is used to indicate the center of gravity (COG) of a fully nested mast.

Section 2 Introduction

Thank you for selecting The Will-Burt Company for your critical payload elevation needs. These operating instructions describe transporting, handling, installing, operating, maintaining, storing, and troubleshooting procedures for Yacht Masts. These procedures assume the use of standard mast systems. Procedures and characteristics for mast systems customized to meet customer-specific needs may vary.

These operating instructions are intended for professionals who are qualified by their appropriate training and experience to perform the procedures. Review this document in its entirety. Contact The Will-Burt Company with any questions before performing any procedure outlined in this manual.

The views depicted in this manual are provided for clarification and are subject to change without notice. Views are not to scale.

The following models are covered in these operating instructions:

- Yacht Mast (Non-Locking)
- Yacht Mast (Locking)

2.1 Safety Precautions

Refer to the Safety Summary for precautions to be observed while operating or servicing this equipment.

2.2 Intended Use

The Yacht Mast is intended for use by professionals. It is not intended for use by non-professionals. Do not use the mast to lift personnel. The mast system is intended to be installed in a vehicle/vessel.

The Yacht Mast is intended to be used only when the vehicle/vessel is not in waters that are dangerous or have large waves. If waters are dangerous, retract the mast.

2.3 Definitions

The following terms are used throughout this manual:

- **System:** refers to the entire mast system, controller, and other optional accessories
- **Payload:** refers to the object or equipment being extended by the mast to an operational height

2.4 Mast Component Descriptions

This section describes major components of a mast system assuming the use of standard catalog mast systems. Characteristics of components customized to meet customer-specific needs may vary. If necessary, contact The Will-Burt Company for additional details.

The exact configuration of the mast may vary. For detailed information on the locations of components in your system, see the drawings that shipped with the system.

Telescoping Mast: The telescoping mast is the structure used to raise the payload to an operational level. It consists of several concentric, nesting mast sections, fabricated from aluminum tubes, that extend and retract pneumatically. The two types of telescoping mast described in this manual are:

- Non-locking masts must remain pressurized to support the payload at an extended height. Allowing depressurization allows the mast and payload to lower.
- Locking masts which are depressurized once the desired tubes are raised and locked into position. The locks support the payload.

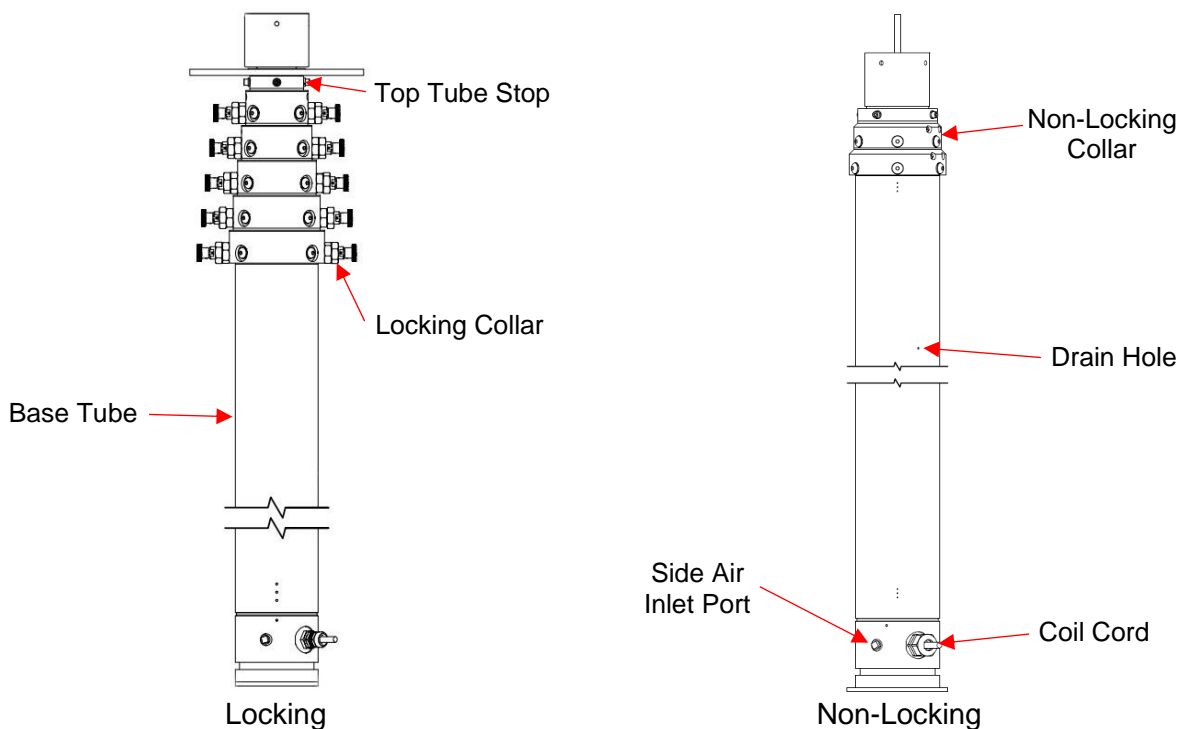

Figure 2-1 Telescoping Masts (Not to Scale)

The base mast section is constructed from the tube with the largest diameter and the top mast section is constructed from the tube with the smallest diameter. The intermediate mast sections are any mast section in between the base and top mast sections.

Collars are fitted to the top end of each mast section, except for the top mast section, which is fitted with a top tube stop. When the telescoping mast is completely retracted, the collars nest on top of each other. Each mast section, except the base mast section, has two rectangular keys along the length of the tube. The keys match with keyways on the larger, adjacent mast section's collar. The keys and keyways are used to establish azimuth (rotational) integrity between the sections. Identification plates are secured to the collar on the base mast section.

The internal coil cord exits both the top and the bottom of the mast assembly through a liquid tight strain relief. The strain relief grips the cord and provides for an airtight seal. Masts with 5-inch diameter base tubes are equipped with a cord consisting of (10) 14 AWG wires, (2) 18 AWG wires and (2) 20 AWG wires.

Hardware Bag: The hardware bag is a plain bag that includes screws for attaching mast mounting hardware to the mast. Because of the varied installation circumstances, the hardware required to attach the mast to a vehicle/vessel or structure must be supplied by the installer. The hardware bag also contains a safety valve, for protection from over pressurization, and brass fittings for water drainage and connecting the mast to the air supply line. Do not operate the mast until the safety valve has been properly installed.

Weep Hole Drain Kit: The drain kit, sealed in a clear plastic bag, includes installation instructions, a length of clear plastic tube and fittings to outfit the telescoping mast with a means to drain water that has entered the top and intermediate mast sections and may cause damage. Use the drain cock from the hardware bag to drain water from the base mast section. The fittings are used to attach one end of the plastic tube to the weep hole in the base mast section and to route the other end of the tube outside the mounting structure or vehicle/vessel to drain water. Refer to the sheets included with your weep hole drain kit for detailed assembly instructions.

Non-Rotatable Base Plate: The non-rotatable (NR) base plate is a square aluminum plate used to stabilize the mast and to provide a means of securing the mast to a mounting structure. Countersunk holes in the NR base plate match threaded holes on the base mast section. Flat head screws included in the hardware bag can be used to attach the NR base plate to the base tube.

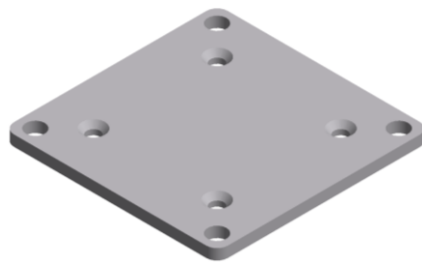

Figure 2-2 Non-Rotatable Base Plate

Internal Mount Bracket: The internal mount bracket is used to secure the mast to a support structure.

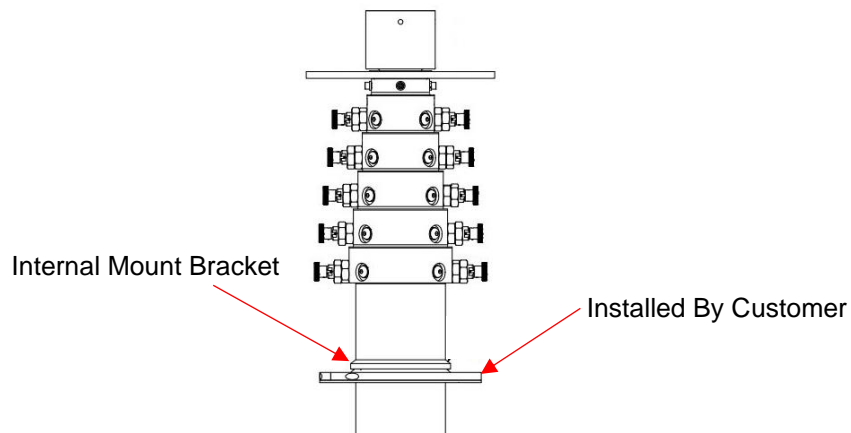

Figure 2-3 Internal Mount Bracket

Internal Mounting Kit: The internal mounting kit contains the hardware used to position and support an internally mounted mast. Customer-supplied ¼ inch (M6) bolts, lock washers, and hex nuts shall be used as fasteners. Bolt length depends on the specific application and is to be determined by the customer. Internal mounting kits include:

- (2) Mounting Bracket Half
- (1) Ceiling Gasket
- (2) SCR CAP M5 or CS M5
- (1) Wear Ring
- (1) V-Seal

For more information on mounting kit options, see www.willburt.com.

Pneumatic System: The pneumatic system refers to a means of safely controlling the pressurization and depressurization of the telescoping mast. Components in the hardware bag and a port near the bottom of the base mast section are provided to connect an air supply to the telescoping mast. See Section 4.11 for additional information on the pneumatic system.

Guy Line Kit Options (Sold Separately): Guy line kits are used to further stabilize the mast by resisting environmental conditions that may cause tip-over and horizontal payload moment. Guy lines attach to guy lugs, which are located on the collars of the mast. Use of a guy line kit may be required for customer-specific payloads or to achieve specific survival wind speeds. Consult The Will-Burt Company's engineering.

Note: Not all masts have guy lugs. Before considering a guy line kit, make sure your mast is guy line compatible.

The exact configuration of the guy kit will vary based on the mast configuration and environmental requirements. Some guy kits require a payload platform or stub adaptor that can be directly guyed. Components may include:

- Guy Line Assemblies
- Guy Line Anchors
- A Guy Line Anchor point location drawing

For additional information on guy kits, see www.willburt.com.

(This page is intentionally left blank.)

Section 3 Technical Data

Table 3-1 Locking Yacht Masts

	Payload Capacity	Extended Height	Nested Height	Approx. Mast Weight	No. of Sections	Section Diameter	Max Operating Pressure
5.3-18	70 lb.	18 ft	5.3 ft	77 lb.	6	5 – 2.5 in	20 PSIG
	31.8 kg	5.4 m	1.6 m	35 kg		127 – 63.5 mm	1.4 bar
7-29	70 lb.	29 ft	7 ft	102.4 lb.	6	5 – 2.5 in	20 PSIG
	31.8 kg	8.8 m	2.1 m	46.5 kg		127 – 63.5 mm	1.4 bar
12-30	170 lb.	30 ft	12 ft	92.2 lb.	3	5 – 4 in	20 PSIG
	77.1 kg	9.1 m	3.6 m	41.9 kg		127 – 101 mm	1.4 bar
9-32.2	70 lb.	32.2 ft	9 ft	110.2 lb.	6	5 – 2.5 in	20 PSIG
	31.8 kg	9.8 m	2.7 m	50.1 kg		127 – 63.5 mm	1.4 bar
7.8-32.6	70 lb.	36.2 ft	7.8 ft	103.1 lb.	6	5 – 2.5 in	20 PSIG
	31.8 kg	11 m	2.4 m	46.9 kg		127 – 63.5 mm	1.4 bar
7.6-33.6	70 lb.	33.6 ft	7.6 ft	104.7 lb.	6	5 – 2.5 in	20 PSIG
	31.8 kg	10.2 m	2.3 m	47.6 kg		127 – 63.5 mm	1.4 bar
9-34.8	70 lb.	34.8 ft	9 ft	111.6 lb.	6	5 – 2.5 in	20 PSIG
	31.8 kg	10.6 m	2.7 m	50.7 kg		127 – 63.5 mm	1.4 bar
9-36.3	70 lb.	36.3 ft	9 ft	111.6 lb.	6	5 – 2.5 in	20 PSIG
	31.8 kg	11.1 m	2.7 m	50.7 kg		127 – 63.5 mm	1.4 bar
9-40	70 lb.	40 ft	9 ft	115.5 lb.	6	5 – 2.5 in	20 PSIG
	31.8 kg	12.2 m	2.7 m	52.5 kg		127 – 63.5 mm	1.4 bar
<p>Note:</p> <ul style="list-style-type: none"> • Payload Capacity assumes a 12 Inch Maximum Offset Payload and a Mast Deployment Angle 0° to 5°. • Payload Capacity will be affected by wind sail area; consult factory. Payload Capacity includes cable weight. • Section Diameter listed as Base Mast Section Diameter – Top Mast Section Diameter. • Dimensions and specifications provided are for reference only, and are not intended for vehicle/vessel design purposes. • Specifications may be subject to change without notice. 							

Table 3-2 Non-Locking Yacht Masts

	Payload Capacity	Extended Height	Nested Height	Approx. Mast Weight	No. of Sections	Section Diameter	Max Operating Pressure
7-16	170 lb.	16 ft.	7 ft.	49.5 lb.	3	5 – 4 in	20 PSIG
	77.1 kg	4.8 m	2.1 m	22.5 kg		127 – 101 mm	1.4 bar
8-21	170 lb.	20.5 ft.	8 ft.	56.4 lb.	3	5 – 4 in	20 PSIG
	77.1 kg	6.2 m	2.4 m	25.7 kg		127 – 101 mm	1.4 bar

Note:

- Payload Capacity assumes a 12 Inch Maximum Offset Payload and a Mast Deployment Angle 0° to 5°.
- Payload Capacity will be affected by wind sail area; consult factory. Payload Capacity includes cable weight.
- Section Diameter listed as Base Mast Section Diameter – Top Mast Section Diameter.
- Dimensions and specifications provided are for reference only, and are not intended for vehicle/vessel design purposes.
- Specifications may be subject to change without notice.

Section 4 Installation

This section provides instructions for installing the Yacht Mast and provides the general procedures that must be followed to ensure a successful installation. Be sure to read and understand the entire installation procedure and the Safety Summary (Section 1) before beginning installation.

4.1 Pre-Installation Check

Before installing the mast system, ensure:

- All installers read and understand the entire installation procedure.
- Only a properly trained and qualified certified electrician performs electric installations and maintenance.
- The mounting structure is level and has sufficient room and strength to mount the mast system.
- All purchased components are included (Section 2.4).
- All required equipment is readily available (Section 4.2).
- When installing in a vehicle/vessel, ensure that the vehicle/vessel is docked and that the waters are relatively calm.

4.2 Recommended Installation Tools

Table 4-1 lists recommended tools and materials for installation.

Table 4-1 Tools and Materials Required for Installation

Tools and Materials		
Wrenches	Screwdrivers	Thread Tape
Safety Gloves	Sling / Strap	Measuring Tape
Sockets	String or Thin Wire	Plumb Bob
Hoist	Torque Wrench	Safety Glasses
Hammer	Level	Saw
Drill	Air Supply	Pipe Thread Sealant or PTFE Tape
Loctite® 242/243 (Blue) or Equivalent		
Note: Depending on the national and local standards and codes of practice, and the environment, additional personal protective equipment may be necessary.		

4.3 Unpacking and Handling

Unpack and handle the mast as follows:

1. Carefully open shipping crate.
2. Remove all loose parts, the 2 x 4 inch (38 x 89 mm) block at the top end of the mast and the top half of the wooden mast saddles (Figure 4-1).

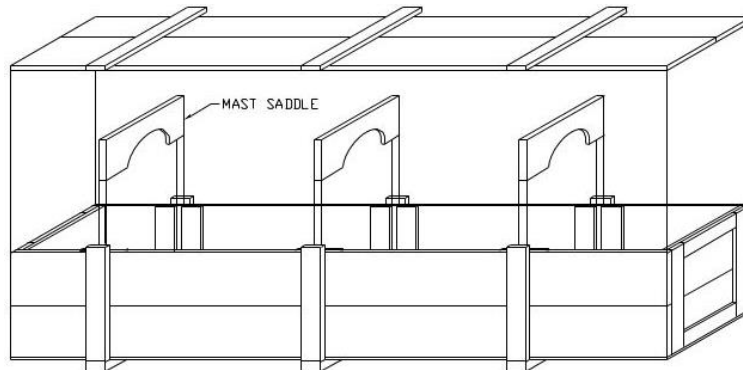

Figure 4-1 Shipping Crate

3. Ensure all components are included and that the required tools are readily available.
4. Inspect for any shipping damage. If damage has occurred, notify the carrier.
5. Outfit the mast with a sling capable of supporting the mast weight (Figure 4-2). The sling should support the mast from at least two points. Attach the sling such that horizontal balance and control can be maintained while positioning the mast. Hoist and slowly lift the mast until just free of the mast saddles. Lower the mast and adjust the sling as necessary to balance the mast. Hoist the mast free from the crate and carefully move the mast into the desired position.

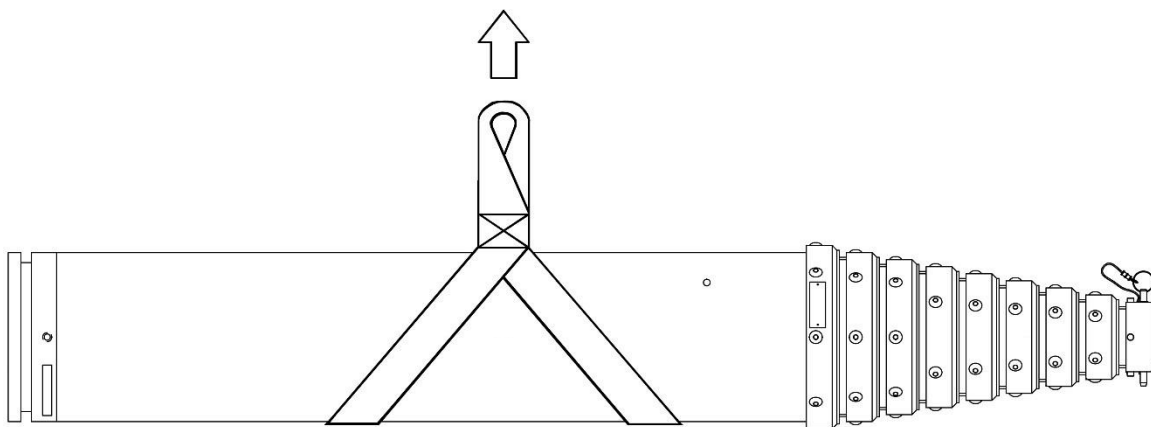

Figure 4-2 Hoist the Mast (Pneumatic Mast Shown)

The Will-Burt Company recommends keeping the shipping crate for transporting the mast, for example if shipping the mast back to the factory for refurbishment.

4.4 Select a Suitable Mounting Location

To select a suitable mounting location, consider the following:

- The mounting area must have sufficient room to mount the mast system. The roof area must be as flat as possible at the location of the mast. The roofline must lie in between the weep hole and base tube collar. Mounting hardware should be at least 1 inch (25 mm) above the weep hole and 3 inch (76 mm) below the collar (Figure 4-3). The exact dimensions of the mast system will vary based on the components included.

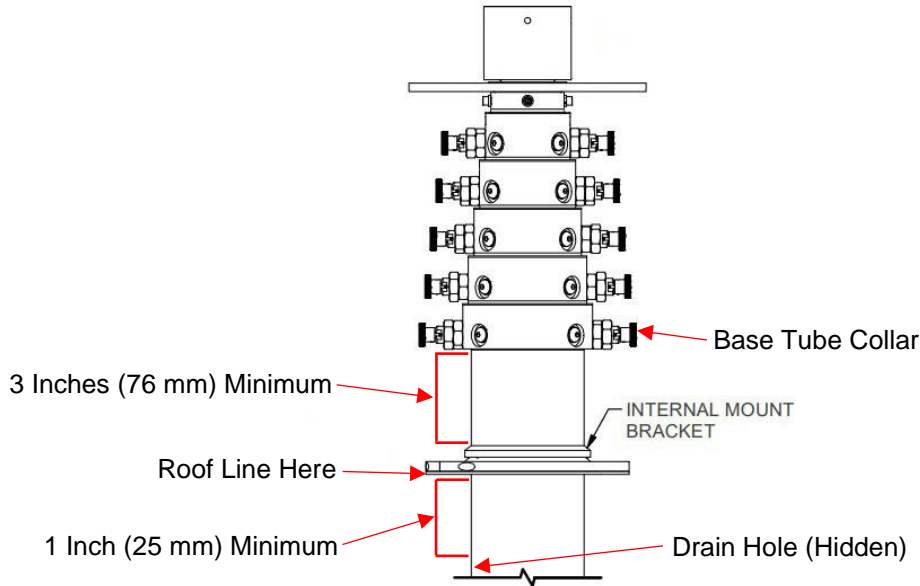

Figure 4-3 Roof Line Location (Locking Mast Shown)

- The mounting structure must be level, solid, and capable of holding the forces required by the bolts. Check the strength and rigidity of the mounting structure (e.g. vehicle/vessel body) where the mast system is to be attached. Reinforce as necessary.
- The area underneath the floor must be free of obstructions to allow for accessibility to base plate fasteners, and if present and used, the bottom air inlet port.
- The mounting location must have sufficient access for the pneumatic system.
- Before cutting the hole in the roof, it is advised to hang a plumb bob from the roof to find the base plate location and ensure proper alignment between the roof hole and intended base plate location. This is particularly helpful when attempting to hit specific structural members beneath a vehicle/vessel.
- As mast tubes extend, they force water out of the weep holes. Keep any personnel or sensitive equipment away from the weep hole direction.

4.5 Begin Installation

Physically attach the system as follows:

1. Remove any roofline or ceiling panels.
2. Cut a round hole in the roof $\frac{1}{4}$ -inch larger than the diameter of the mast base section. Cut the same size hole in the roof liner or ceiling panel.
3. Center the ceiling plate over the hole. Use it as a template to drill bolt holes for attachment.
4. If necessary, use washers or short spacers made of $\frac{1}{4}$ -inch (6.35 mm) pipe to level out any irregularities that exist in the roof.

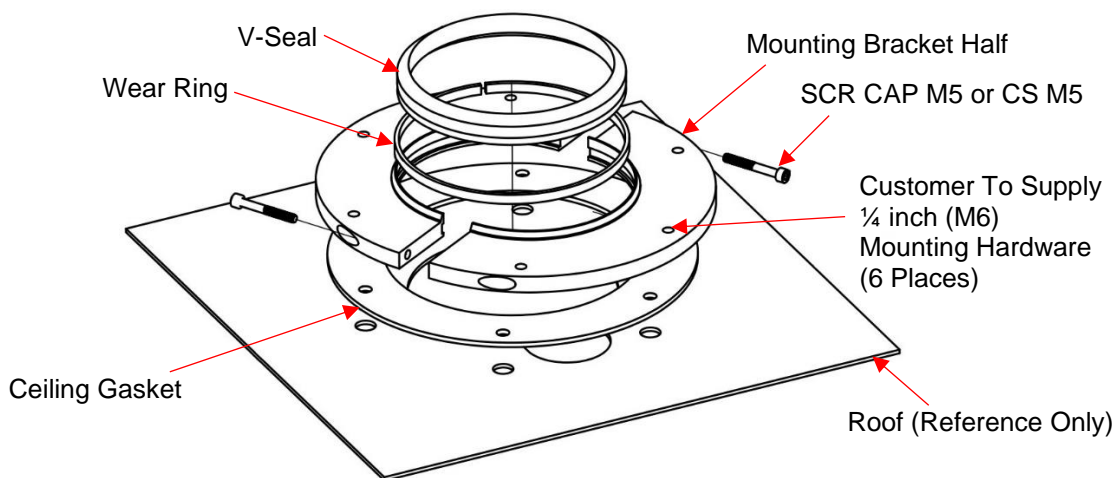

Figure 4-4 Internal Mounting Kit

5. To assemble the roof mounting hardware, line up all holes and fit the ceiling gasket to the roof. Line up all holes and fasten this assembly together using the appropriately sized fasteners. The $\frac{1}{4}$ -inch or M6 bolts (customer-provided) should be sized to length to allow for the thickness of any bolt fasteners (not provided) and the mounting kit hardware. Stainless steel or stronger bolts are recommended. Securely tighten all nuts. It is up to the installer to ensure proper thread-locking methods are used to keep the bolts from backing out due to vehicle/vessel vibration.
6. Replace the roof liner or ceiling panel before installing the mast.

4.6 Lower Mast Through the Internal Mounting Kit

To lower the mast through the internal mounting kit:

1. Use a hoist to slowly lift the mast above the roof.
2. Align the base of the mast with the center hole of the internal mounting kit.
3. Carefully lower the mast partially through the roof. The mast should be held securely in position partially through the roof so that the installer has safe access to the base of the mast to install the base plate.

4.7 Attach the Base Plate to the Mast

When installing the base plate to the base of the mast, ensure the mast is securely held in position. To install the base plate:

1. The base plate must be attached before lowering the mast to the floor. Position the base plate against the base of the mast so the mounting holes align. Ensure the countersunk holes are facing away from the mast.
2. Secure the base plate to the mast with the (4) ¼-20x.0625 flathead screws (P/N: 3612) from the hardware bag. Apply Loctite® 242/243 (Blue) or equivalent. Torque to 190-240 in.-lb.

4.8 Position the Mast

To position the mast:

1. Lower the mast the rest of the way to the floor.
2. Carefully move the mast into position, ensuring the mast is level. It is necessary to check the mast in two places 90° apart when leveling. Be certain to orient the mast so the operator has a clear view of the hazard labels.

Note: Additional labels are provided with the operator's manual and should be installed where the operator will have a clear view of them while operating the mast.

4.9 Secure the Base Plate to the Mounting Surface

To secure the base plate to the mounting surface:

1. Use the base plate as a template to drill holes through the mounting surface.
2. Ensure the base plate and mast are level in all directions. It is necessary to check the mast in two places 90° apart when leveling.
3. Secure the base plate to the mounting surface with appropriate hardware. To secure the base plate, the hardware bag contains:
 - a. (4) $\frac{3}{8}$ -16x1- $\frac{1}{2}$ Inch Bolts (P/N: 901594)
 - b. (4) Flat Washers (P/N: 2054)
 - c. (4) Lock Washers (P/N: 0801)
 - d. (4) Nuts (P/N: 901593)

Depending on the customer-specific mounting application, other (customer-supplied) hardware may be required. The mounting hardware must include proper means to resist vibration loosening such as thread-locking compound or locking hardware. Torque to 190-240 in.-lb.

4.10 Weep Hole Drain Kit Installation

The intended use of the weep hole drain kit is to route water, from inside the mast, outside a vehicle/vessel or enclosure to protect the interior of a vehicle/vessel or other water sensitive area from damage due to water drainage. The weep holes on each mast section are located to facilitate the drainage of water during periods of extension. Water can enter the mast through condensation in the air supply or by rain running down the mast sections and entering at the collars. Water that freezes in or on the mast can cause the mast to work erratically or not at all. Keeping water out of the mast is very important to avoid damage to the mast and possible delays in operation.

A drain cock, provided in the hardware bag, should also be connected to the air inlet near the base of the mast. The drain cock shall be opened when the mast is not in use, or when a locking mast is deployed and depressurized, to empty water that may accumulate inside the base tube, particularly after the mast has been exposed to rain.

Note: Complete internal mast installation before installing the weep hole drain kit.

To install the weep hole drain kit:

1. Be certain the locknut and washer are threaded over the end of ¼-inch hose adapter (Figure 4-5).

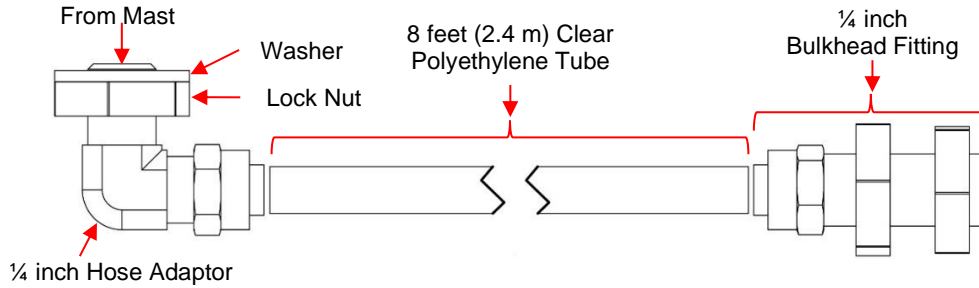

Figure 4-5 Drain Kit (P/N: 902982)

2. Fasten hose adapter to base mast section weep hole (Figure 4-6). Apply PTFE tape to all threaded joints. Turn the hose adapter in ONLY 1 ½ to 2 turns after initial engagement of threads. Further turning will damage mast. Tighten the locknut to secure in place.

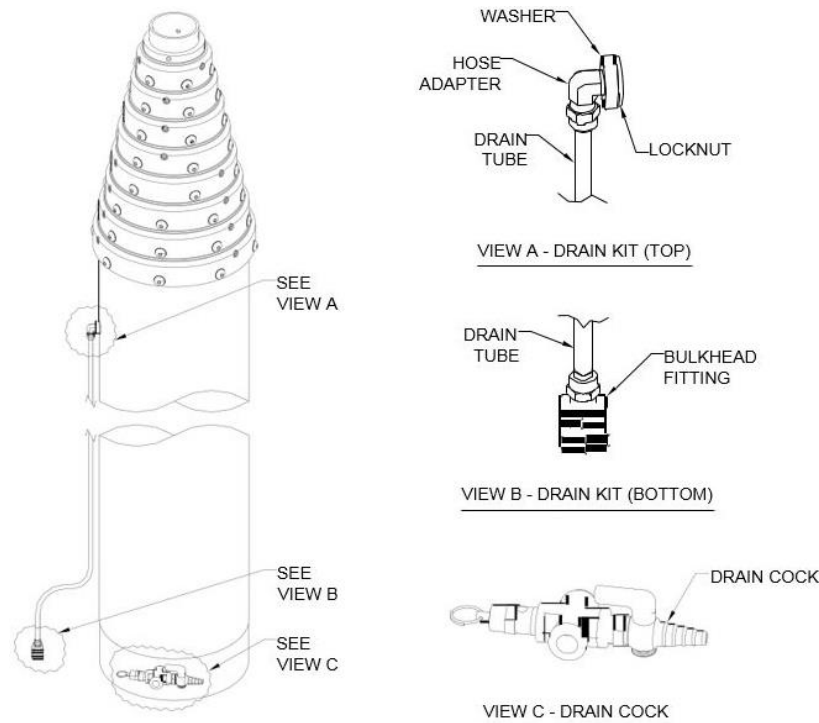

Figure 4-6 Weep Hole Drain Kit

3. Drill a hole in vehicle/vessel or enclosure to route water outside.
4. Fasten the bulkhead fitting to the hole (Figure 4-5).
5. Attach the polyethylene tube to the hose adapter and the bulkhead fitting (Figure 4-5). As necessary, the polyethylene tube may be cut shorter to fit the customer-specific application. Apply PTFE Tape to all threaded joints.

4.11 Pneumatic System Installation

This section describes general principles to keep in mind during installation of the pneumatic system. Depending on the components of the mast system and the environment, the exact configuration of the pneumatic system may vary. Use the best and safest method for your circumstance. Use only CE marked systems for use in EU.

Air to operate the mast may be provided by an air compressor or other source of clean dry air. The pneumatic system should be regulated to not exceed the maximum operating pressure of the mast. The maximum recommended operating pressure is 20 PSIG (1.4 bar).

4.11.1 General Concepts

While installing the pneumatic system, keep the following in mind:

- **Mounting:** When mounting the pneumatic system, leave enough space around the unit for ventilation and for access to make initial installation, periodic adjustments, and future maintenance procedures as easy as possible. To reduce vibration in the system, place rubber washers or grommets on the bolts between the mounting pads and the mounting surface. To reduce noise, separate the system from the inside workspace of the vehicle/vessel.
- **Electrical:** In accordance with applicable electrical codes, select the proper wiring size, circuit breakers, or fuse size according to the maximum current draw of the pneumatic system being installed. Refer to rating information plate on the compressor motor. Be sure to properly ground the compressor motor and all other electrical components. Operation of the compressor may cause interference unless proper isolation or shielding is used. Note: A qualified electrician should perform installation and adjustments.
- **Air Supply:** The air supply should have adequate ventilation to provide a sufficient amount of clean, dry air at the air intake at all times. The air supply should not be operated without the air filters in place.
- **Air Control Valve:** An air control valve should be installed to direct airflow in and out of the mast. The air control valve should be positioned to avoid unintentional operation. Mast movement should stop when the controller is released (hold-to-run type). The air control valve should be operable by a person wearing gloves and mounted so it can be used with the mast in full view. The air control valve should be suitable for outdoor use, and marked "Up", "Down", or similar. A check valve or similar device should be installed directly to the mast through rigid piping that would prevent an extended mast from exhausting uncontrollably if there is a pneumatic failure, such as a hose burst.

- **Drain & Relief Fittings:** A drain cock and safety valve must be installed at the air inlet port at the base of the mast. The drain cock empties water that may have accumulated inside the mast. The drain cock should be opened periodically to drain the mast, particularly after the mast has been operated in the rain. The drain cock should be left open once the mast is fully retracted and once a locking mast is completely extended and locked into position. The safety valve prevents the mast from being over pressurized.
- **Plumbing:** A length of air hose with an ID of $\frac{3}{8}$ inch (9.5 mm), plus additional loose fittings, are supplied with a The Will-Burt Company pneumatic system if purchased. The air hose can be cut to the required length at installation. A drain hose should be attached to the exhaust port of the air control valve to drain condensation or oil mist that may exhaust from the mast. Do not remove any hose without first completely exhausting all air from the mast and then disconnecting the power supply.

4.11.2 General Procedures

This section describes general procedures and concepts to use when installing the pneumatic system. Depending on the components and configuration of your system, the exact steps and procedures may vary. Use the best and safest method for your system.

Figure 4-7 shows the general layout of a pneumatic system. The exact configuration will vary based on the components being used in the specific system.

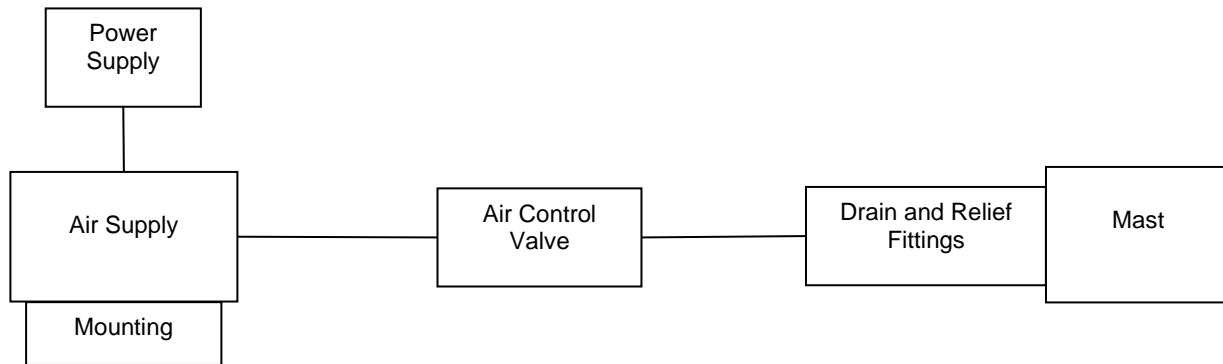

Figure 4-7 General Pneumatic System Layout

To install the pneumatic system:

1. Locate the hardware bag. Components from the hardware bag will be used during installation of the pneumatic system.
2. Locate the air inlet port to be used. Depending on the configuration of the mast, there may be more than one air inlet port available. When installing the pneumatic system, only use one air inlet port.
 - To use the air inlet port with the plastic plug:
 - a. Remove the plastic plug. This plug is for thread protection only and the mast should never be pressurized with this plug installed.
 - To use the air inlet port with the stainless steel plug:
 - a. Remove the plastic plug.
 - b. Remove the stainless steel plug. Install a customer-supplied $\frac{1}{4}$ inch (6.35 mm) stainless steel plug in the air inlet port that is not going to be used to attach the pneumatic system. Pipe thread sealant or PTFE tape should be applied to minimize leakage.

Note: The plastic plug is for thread protection only. The mast should never be pressurized with the plastic plug installed. Ensure any unused air inlet port is plugged with a stainless steel plug.

3. Attach the brass cross to the desired air inlet port with a close nipple (Figure 4-8). Apply PTFE tape to all threaded joints. If necessary, an air hose may be used to connect between the air inlet port and the brass cross, however, the brass cross should be installed as close to the mast as possible to ensure proper drainage.

Note: If desired, swivel fittings (P/N: 900481 and P/N: 900483) are available for use with the bottom air inlet port.

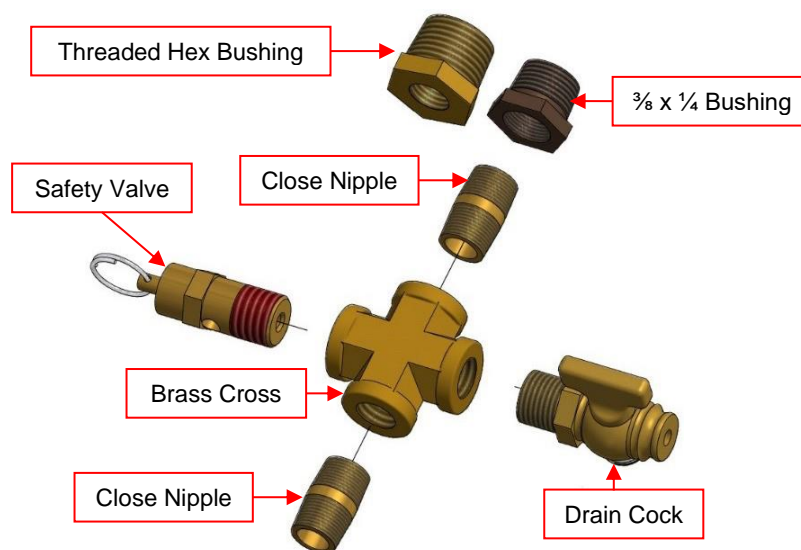

Figure 4-8 Pneumatic System Installation

4. Attach the safety valve to the brass cross. Apply PTFE tape to all threaded joints.
5. Attach the drain cock to the brass cross. Apply PTFE tape to all threaded joints.

Note: The drain cock should be located at the lowest point. When the mast is not in use, or when a locking mast is deployed and depressurized, the drain cock shall be left open.

6. If necessary, mount the air supply to the mounting structure with appropriate hardware. The mounting hardware must include proper means to resist vibration loosening such as thread-locking compound or locking hardware. Torque all hardware as appropriate for its size and grade.

Note: The air supply should not be operated without air filters in place.

7. Connect the air supply to the brass cross with air hose and a close nipple. Apply PTFE tape to all threaded joints.

Note: Depending on the air supply used, it may be necessary to install an air control valve inline between the air supply and the brass cross.

8. If necessary, connect the power supply to the air supply. Be certain to observe any local codes or regulations.

4.12 Test the Installation

Follow all precautions while testing the mast system installation.

To test the installation:

1. Review the Pre-Operation Check (Section 5.1) and prepare the mast system for operation.
2. Extend the mast (Section 5.3.1.1 or Section 5.3.2.1).
3. Lower the mast (Section 5.3.1.2 or Section 5.3.2.2)

Note: The drain cock shall remain open to drain water when the mast is not in use. For locking masts, the drain cock shall be opened while the mast is deployed and depressurized to drain water. It is not uncommon to have mast grease exit the drain or exhaust valve on initial mast use.

See Section 5 for additional details on these procedures.

4.13 Install the Payload

The exact installation procedures for payload will vary based on the customer-specific payload. For optimal performance, center the payload as best as possible. If the payload must be offset, offset the payload in-line with the keys. Contact The Will-Burt Company with any questions before performing any installation procedures.

In general, to install the payload:

1. Ensure the air supply is disconnected, and the drain cock is opened while installing the payload to eliminate the possibility of inadvertent mast extension.
2. If necessary, remove the mast top cover.
Note: If the payload is removed, the mast top cover should be put back on.
3. Carefully move the payload into position.
4. Properly secure the payload to the mast. The mounting hardware must include proper means to resist vibration loosening, such as thread-locking compound or locking hardware. Torque all hardware as appropriate for its size and grade.

Note: If securing a payload part-way along a mast tube, be sure not to overtighten the tube, or damage to the mast could occur. Intermediate tube clamps are available to assist in attaching payloads to the intermediate tubes. See www.willburt.com for additional information.

Section 5 Operation

This section describes the operation of the mast system. Be sure to read and understand the entire operation procedure and Safety Summary (Section 1) before beginning operation.

5.1 Pre-Operation Check

Before operating the mast system, ensure:

- All operators read and understand the entire operation procedure and are properly trained.
- The mast system is undamaged. If damage is apparent, do not use the mast system, and have it serviced prior to use.
- All electrical cables are undamaged and properly terminated.
- The area is free of power lines or other overhead obstructions. The mast system location should be no closer than a horizontal distance equal to the extended height of the mast away from power lines.
- Any objects that might obstruct motion of the mast system, cause binding, or hinder mast system function are removed.
- The mast system and payload are properly installed.
- When using a vehicle/vessel, ensure that the waters are relatively calm.
- Any transit tie-downs have been removed.
- The mast system area is free of personnel.
- The operator has full view of the mast system during use.
- Prepare the pneumatic system for operation. As part of this:
 - Close the drain cock.
 - Connect the air supply to the mast.
 - If necessary, connect power to the air supply.
- Ensure the proper personnel are available to operate the mast. For applications using guy lines, a minimum of:
 - (2) People are necessary to operate the guy lines (Guy lines must be operated opposite of each other).
 - Person must observe the mast to ensure it is standing straight and not leaning in any direction. For taller masts, binoculars may be required.
 - Person must operate the pneumatic system. It may be possible for the person observing the mast to also operate the pneumatic system.

Check with The Will-Burt Company's Engineering for additional wind information for customer-specific loading scenarios.

5.2 Operation Equipment

Table 5-1 lists recommended equipment for operation.

Table 5-1 Equipment Recommended for Operation

Recommended Equipment			
Personal Protective*			
	Safety Glasses	Work Gloves	Nitrile or Vinyl Gloves
	Hearing Protection	Hard Hat or Helmet	Safety Shoes
*Depending on the national and local standards and codes of practice, and the environment, additional personal protective equipment may be necessary.			

5.3 Mast Operation

This section describes operation of the mast system. The exact operating procedures will vary based on the configuration of your mast system. Follow the appropriate operation procedures for your mast system.

5.3.1 Non-Locking Mast Operation

The following are detailed steps of operation for the non-locking mast.

5.3.1.1 Extending the Mast

As mast tubes extend, they force water out of the weep holes. Keep any personnel or sensitive equipment away from the weep hole direction while extending the mast.

To extend the mast:

1. Prepare the mast system for operation (Section 5.1).
2. If necessary, remove the canvas top cover.
3. If necessary, secure the payload and any required cables to the mast (Section 4.13).
4. Attach the pneumatic system to the mast. Using the control valve, pressurize the mast to extend it. Do not exceed the maximum recommended operating pressure of the mast at any time, which is 20 PSIG. Maintain visual contact with the mast throughout extension to avoid cable entanglements or overhead obstructions.
5. Stop pressurizing the mast when the desired height is achieved. The mast must remain pressurized to maintain its height. Note that partially extended, non-locking masts may move due to internal air temperature changes.

5.3.1.2 Lowering the Mast

To lower the mast:

1. Ensure the payload will have enough clearance when nested.
2. Using the control valve, exhaust air from the mast. The mast will retract by its own weight and the weight of the payload. Maintain visual contact with the mast during retraction to avoid cable and/or payload hang-ups.
3. Periodically open the drain cock when exhausting the mast to drain off any accumulated water.
4. Disconnect the air supply to eliminate the possibility of inadvertent mast extension.
5. Open the drain cock while the mast is not in use. If the drain cock is not left open when not in use, it can collect condensation and fill up with water. This water can freeze, which causes the mast to not function correctly or break.
6. Securely tie the canvas top cover (if used) over the mast.
7. Always visually confirm that the mast is fully retracted before moving the mast.

5.3.2 Locking Mast Operation

The following are detailed steps of operation for the locking mast.

5.3.2.1 Extending the Mast

As mast tubes extend, they force water out of the weep holes. Keep any personnel or sensitive equipment away from the weep hole direction while extending the mast.

To extend the mast:

1. Prepare the mast system for operation (Section 5.1).
2. If necessary, remove the canvas top cover.
3. If necessary, secure the payload and any required cables to the mast.
4. If guy lines are used, attach the guy lines to the color-coded lugs on the collars.

- Prior to extending the mast, The Will-Burt Company recommends laying out any guy lines so they do not become tangled during extension (Figure 5-1).

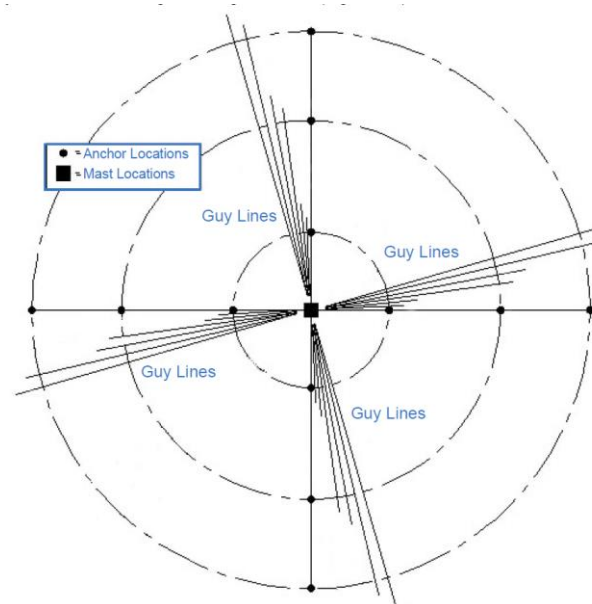

Figure 5-1 Sample of Laying Out Guy Lines (Mast with 4 Way 5 Level Guying Shown)

- If guy lines are used, find the guy line anchor locations and install the guy line anchors.
- Ensure the payload has enough clearance as the mast is extended.
- Attach the pneumatic system to the mast.
- Unlock the top tube collar. To unlock the collar, pull on both locking knobs and rotate them 90°. Continue pulling until the roll pin is disengaged from the slot on the latch body and release. At this point, the locking pins should be disengaged (Figure 5-2).

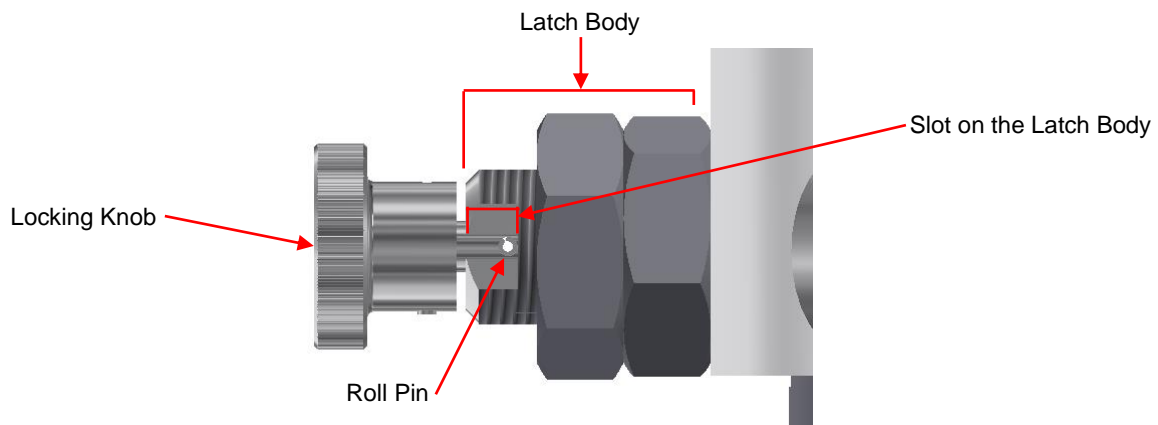

Figure 5-2 Locked Collar View

- Using the control valve, pressurize the top tube section. Do not exceed the maximum recommended operating pressure of the mast at any time, which is 20 PSIG.

11. Once the tube is fully extended, relock the top tube collar. To relock the collar, pull out both locking knobs and rotate 90° until the roll pin goes back into the slot of the latch body (Figure 5-2).
12. Unlock the next section tube collar. Pressurize the tube section. Once it fully extends, relock the section tube collar. Do this procedure for every mast section until all tubes are fully extended and tube section collars are locked.
13. Maintain visual contact with the mast throughout extension to avoid cable entanglements or overhead obstructions.
14. Exhaust all air from the mast to confirm the mast tube is locked. If the tube comes down, repeat steps 7 to 13.
15. If guy lines are used, properly secure and tension the guy lines immediately after raising the mast. The installer shall verify the guy anchor point strength is adequate to support the guy line forces. All guy lines should be equally tensioned. Beginning at two locations opposite each other, gradually tension each guy line. Vertical alignment of the mast is accomplished by observing the mast perpendicularly to the two guy lines being tensioned to ensure the mast is standing straight, and is not bending too far towards one side (Figure 5-3). Adjust the appropriate guy line as necessary to keep the mast plumb vertically. Check one day after initial install. Check periodically afterwards.

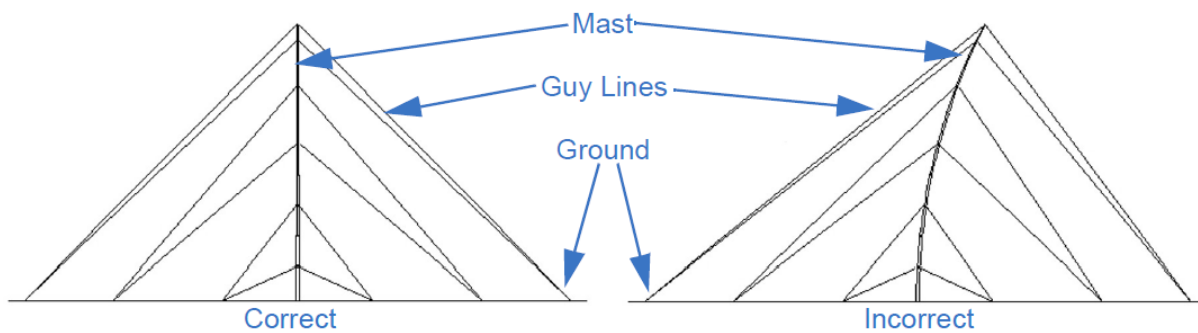

Figure 5-3 Vertically Align the Mast (Sample Shown with 6 Level Guying)

16. Open the drain cock for prolonged deployment to release air pressure and allow for drainage of water which may enter the mast. The drain cock shall be opened while a locking mast is deployed and depressurized to drain water.

Note: When the mast is not in use, leave the drain cock open. If the drain cock is not left open when not in use, it can collect condensation and fill up with water. This water can freeze, which causes the mast to not function correctly or break.

5.3.2.2 Lowering the Mast

To lower the mast:

1. Ensure the payload will have enough clearance when nested.
2. Close the drain cock.
3. If guy lines are used, decrease the tension on guy lines until there is slack in the lines. Never attempt to unlock a mast collar with tension on the guy lines above it. When decreasing tension on the guy lines, begin at two locations opposite of each other, and gradually decrease tension on each guy line while observing to ensure the mast is not bending too far towards one side.

Note: Do not leave mast systems that require guy lines unguyed. If the mast system has not been lowered, and personnel will not be available to operate the guy lines, re-guy the mast.

4. Using the control valve, pressurize the mast. Do not exceed the maximum recommended operating pressure of the mast at any time, which is 20 PSIG.
5. Unlock the lowest tube section collar. To unlock the collar, pull on the locking knobs and rotate them 90°. Continue pulling until the roll pin is disengaged from the slot on the latch body and release. At this point, the locking pins should be disengaged (Figure 5-4).

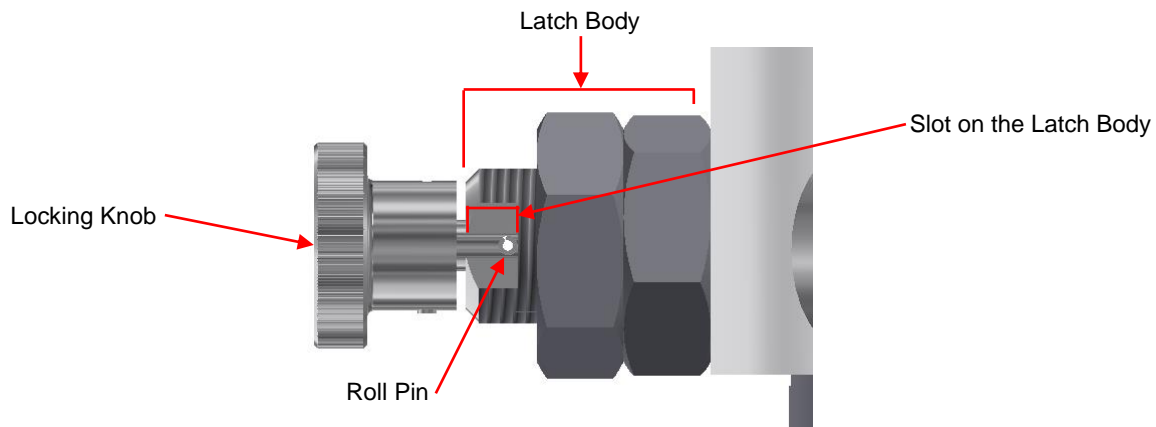

Figure 5-4 Locked Collar View

6. Using the control valve, exhaust air from the mast so that the lowest tube section lowers fully. The mast will retract by its own weight and the weight of the payload.

For systems using guy lines, gently pull guy lines away from the mast as it is lowered. Keeping guy lines organized will facilitate coiling the guy lines for storage, or preparing the guy lines for the next mast extension.

7. Once the tube is fully lowered, relock the collar. To relock the collar, pull out the knobs and rotate 90° until the roll pin goes back into the slot of the latch body (Figure 5-4).

8. Unlock the next lowest tube section collar. Using the control valve, exhaust air from the mast. Once the next tube section is fully lowered, relock the tube section collar. Do this procedure for every mast section until all tube sections are fully lowered and tube section collars are locked.
9. Maintain visual contact with the mast during retraction to avoid cable and/or payload hang-ups.
10. Periodically open the drain cock when exhausting the mast to drain off any accumulated water.
11. To eliminate the possibility of inadvertent mast extension, disconnect the air supply or open the drain cock while the mast is not in use.
12. Remove the guy lines.
13. Remove the payload.
14. Securely tie the canvas top cover (if used) over the mast to protect the mast from water and debris.
15. Open the drain cock when the mast is not in use.
16. Always visually confirm that the mast is fully retracted before moving the mast. For further information on transporting the mast system, see Section 6.

(This page is intentionally left blank.)

Section 6 Transportation

Before transporting the mast system, the mast system needs to be secured. The exact procedures for transportation will vary based on the mast system configuration. The process described in this manual represents a possible method of transporting the mast. Depending on the environment and equipment available, other methods may work better. Use the best and safest method for your circumstances.

6.1 General Transportation

To prepare the mast system for transportation:

1. Ensure the mast is fully nested (Section 5.3). Do not transport the mast system with the mast and payload extended. Always visually confirm the mast is fully retracted before moving the mast.
2. Ensure the air supply is disconnected and the drain cock is open to eliminate the possibility of inadvertent mast extension.
3. Isolate power to the pneumatic system.
4. If possible, remove and secure the payload. For locking masts, the payload should be removed, and the mast top cover fitted over the mast and secured in place.
5. If necessary, secure any additional components in the mast system. Note: The operator should always visually confirm the mast is entirely retracted before moving the vehicle.

6.2 Shipping

When shipping the mast system, The Will-Burt Company recommends shipping the mast in the original shipping crate. If the original shipping crate is not available, contact The Will-Burt Company to order a replacement.

When shipping:

1. As necessary, remove the payload.
2. As necessary, prepare the mast system for transportation (Section 6.1).
3. As necessary, uninstall the mast system from the mounting structure (Section 4).
4. Secure the mast system in the shipping crate:
 - a. Carefully position the mast in the crate.
 - b. When shipping by air, ensure the air inlet port is open.
 - c. Secure the block at the top of the mast to prevent the mast from shifting in the shipping crate during transportation.
 - d. Secure the top half of the wooden mast saddles.
 - e. As necessary, carefully pack any additional components in the shipping crate.
 - f. Secure the lid on the shipping crate.

Section 7 Maintenance, Adjustments and Disposal

This section describes maintenance procedures required to keep the mast system operational. Use care to understand and follow all precautions while performing these procedures. If the system does not perform as required, see Section 8 for troubleshooting.

Disconnect power to any devices mounted to the mast and pneumatic systems with lock-out tagout procedures as appropriate before performing mast maintenance.

To order spare or replacement parts, always refer to the mast model number and serial number. This information is included in the operator's manual supplied with each mast. The mast serial number is stamped at the bottom of the base mast section. Model number, serial number and additional information is also engraved on the mast identification plate(s). The plate(s) are fixed to the base mast section's collar.

7.1 Pre-Maintenance Check

Before performing maintenance procedures, ensure:

- All operators read and understand the entire maintenance procedure and are properly trained.
- The payload is removed prior to performing maintenance on the system.
- The system is level and secure.

7.2 Maintenance Equipment

Table 7-1 lists recommended equipment for maintenance.

Table 7-1 Equipment Recommended for Maintenance

Tools and Materials*			
Personal Protective			
Safety Glasses	Safety Gloves	Safety Shoes	Nitrile or Vinyl Gloves
Hard Hat or Helmet	Hearing Protection		
Hand Tools			
Chisel	Drill	File	Flat Punch
Hammer	Hex Wrenches	Plumb Bob	Measuring Tape
Level	Screwdrivers	Sockets	Wrenches
Torque Wrench	Utility Knife		
Equipment			
Compressed Air Supply	Hoist	Sling / Strap	Ratchet Straps
Saw Horses or Similar Supports			
Expendables			
Acetone, Alcohol, or other solvent	Pipe Thread Sealant or PTFE Tape	String or Thin Wire	Rags (Clean and Dry)
Loctite® 380 Black Max or equal	Loctite® 495 Instant Adhesive	Mast Lubricant	Non-Abrasive Cleaners (Soap and Water)
Pneumatic Mast Grease Kit (P/N: 4258101)			
* Note: <ul style="list-style-type: none"> Depending on the local, regional, and national standards and codes of practice, and the environment, additional personal protective equipment may be necessary. When disposing of any disposables or components, do so according to any applicable local, regional, and national standards and codes of practice. 			

7.3 Cleaning and Lubrication

The Will-Burt Company's Yacht Masts come from the factory pre-lubricated. Under normal operating conditions, the grease applied at the factory is sufficient for five years and no scheduled maintenance is required. In extremely harsh environmental conditions, maintenance of the mast may be required.

An optional mast lubricant (P/N: 900600) may be added to ensure smooth operation and prolong the useful life of the mast in harsh environmental conditions. The mast lubricant is a blue-colored mineral oil specifically designed for telescoping masts and their operating environment. Mast lubricant comes in a 16 oz. capped plastic bottle.

Signs that cleaning and lubrication are needed can be:

- A noticeable gritty film on the exterior surfaces of the mast sections
- Erratic extension or retraction of the mast
- Noisy operation of the mast
- Sticking of one or more mast sections when mast is extending or retracting

To clean the mast:

1. Remove top load from the mast. This allows the tubes of a non-locking mast to more easily be extended from smallest to largest. See step 3. On locking masts, the sequence of extension can be controlled by the locking collars.

2. When a regulator exists in the pneumatic system, reduce its pressure to between 5 and 10 PSIG.

Note: 10 PSIG should be sufficient pressure to extend all sections of the mast without a top load. If any section will not extend with 10 PSIG the mast may require overhaul. Consult the factory.

3. One person operating the air control valve should slowly pressurize the mast just enough to extend the top tube. On non-locking masts, another person may need to hold down the intermediate tube collars to ensure the proper sequence of extension. Close the air control valve or switch as soon as the top tube is extended.
4. Dampen a rag with a non-abrasive cleanser or solvent such as lacquer thinner to wipe down the extended tube. Do not allow the cleaning fluid or solvent to run down inside the collar.
5. If not lubricating the mast, repeat this procedure for each tube from smallest to largest.

6. If lubricating the mast (optional, but helpful in extremely harsh conditions):
 - a. Inject approximately ½ oz. of mast lubricant (P/N: 900600) into the weep hole (drain) of the exposed tube. The weep holes are located between 1 and 3 feet (30 and 91 cm) below the collar on each tube except the top tube.
 - b. Repeat steps 3, 4 and 5 for each of the remaining tubes. The larger diameter tubes should be injected with approximately 1 oz. of lubricant.
 - c. Lower the mast completely. Allow several minutes for the lubricant to settle and spread around the wear ring and seal at the bottom of each tube.
 - d. Extend the mast again one tube at a time in the same sequence (smallest to largest). Wipe off any excess lubricant that flows out of the weep holes.

Note: Do not lubricate the exterior of the mast. This will attract dust and contaminants from the air.

Mast Lubricant is specifically formulated for cold weather use, but is suitable for year around use. Regular winter maintenance and the frequent use of mast lubricant should significantly reduce the potential for mast freeze ups. Mast lubricant is also intended for use in air in-line lubricators.

7.4 Corrective Maintenance

This section describes corrective maintenance for the system. Depending on the mast system configuration and the conditions of the mast system, all corrective maintenance procedures may not be required. Follow the appropriate instructions for your mast system.

Prior to performing corrective maintenance, remove the:

- Payload from the mast
- Mast from the mounting structure

7.4.1 Replace Seals

This section describes replacing the seals on the mast.

Disassemble the mast starting with the top tube and working towards the base tube. Remove any plugs from the air inlet ports.

To disassemble the mast:

1. Place the mast horizontally on a pair of saw horses or similar supports. Secure the base tube to the supports so that the mast does not roll off. Remove any plugs from air inlet ports. Use care to follow all applicable lifting precautions whenever lifting the mast or components of the mast.
2. Start disassembly from the top by pulling the top tube several inches away from the collar and remove the top tube stop. On locking collar models, it is necessary to retract the latch pins to allow the mast section to be pulled out.
3. Remove the collar bolts on the top collar and slide the collar over the end of the tube. On locking collar models, retract the latch pins fully to allow the collar to slide off the end of the tube.
4. Pull out the top tube and set it aside. Use care not to drop the tube as it comes out. Use care to follow all applicable lifting precautions whenever lifting the mast or components of the mast.
5. Remove the wear ring from the butt plate and wipe it clean.
6. Remove the old seal and clean the seal groove.
7. Thoroughly clean and inspect the inside and outside of the tube with a solvent such as lacquer thinner. Do not use anything that might scratch the honed inside surface of the tube. Tubes may need to be cleaned repeatedly before reassembly to remove all debris.
8. Repeat this procedure for each subsequent tube. Be careful not to damage or oblong collar bolt holes when removing the tubes.
9. As necessary, refer to the appropriate section(s) for replacement steps for the following:
 - a. Replacement of the Collar Bearing Strips (Section 7.4.2)
 - b. Replacement of the Wear Rings (Section 7.4.3)
 - c. Replacement of the Internal Bumpers (Section 7.4.4)
 - d. Replacement of the External Bumpers (Section 7.4.5)
10. Oil the new seal with the Pneumatic Mast Grease Kit (P/N: 4258101). With the lip edge of the seal toward the bottom end of the tube, slide it on the butt plate and into the seal groove. Replace the wear ring on the butt plate. Repeat this procedure for each tube.
11. Before reassembling the mast, use the Pneumatic Mast Grease Kit (P/N: 4258101) to lightly oil the lip of the seal and the inside honed surface of each tube, except the top tube. When reassembling the mast, begin with the base tube and work towards the top tube.

12. Secure the base mast section of the mast horizontally on saw horses or similar supports.
13. Using a second person or a brace to support the top end, hold the next tube so that the top end of the tube is at a lower elevation than the seal end. Rest the lip of the seal on the inside of the receiving tube (Figure 7-1). Use care to follow all applicable lifting precautions whenever lifting the mast or components of the mast.

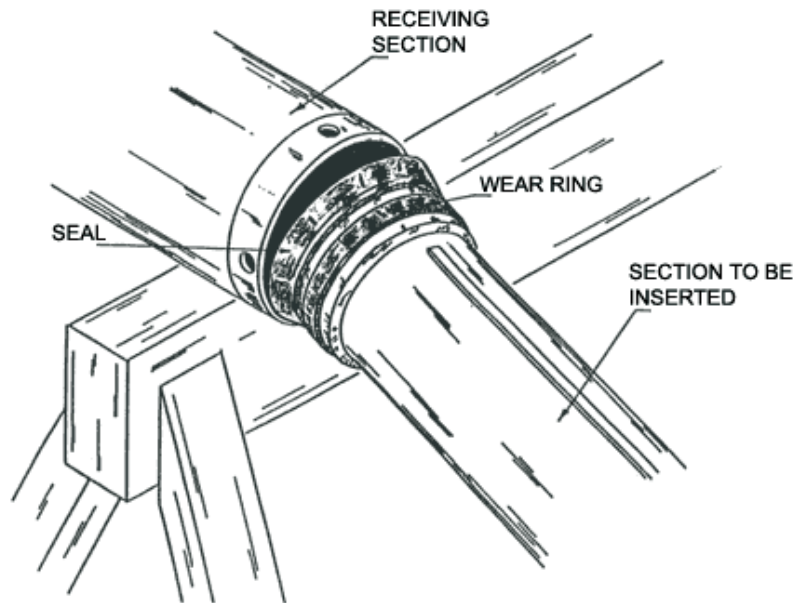

Figure 7-1 Seal Replacement

14. Slowly raise the lower end of the mast section to horizontal while carefully pressing the lip of the seal into the receiving tube. Use your thumbs and forefingers to simultaneously press on both sides of the seal in an upward motion. Work this way until your fingers meet at the top.
 15. Ensure the seal is in properly. If not, the mast will eventually leak air. If the seal has not been inserted into the receiving tube correctly, remove the tube and repeat the process.
 16. Once the seal is inserted, guide the wear ring into position within its groove and slide in the tube. Be careful not to damage the seal as it slides past the collar bolt holes that are located near the insertion end of the receiving section.
 17. Slide the tube in leaving several inches protruding. Rotate the tube so "0" stamps on the tubes are aligned.
 18. Replace the collar on the tube. Align the "0" stamp on the collar with the "0" stamp on the tube. On locking collar masts, retract the latch pins to allow the collar to slide onto the end of the tube. Ensure all bolt holes in the collar align exactly with the holes in the tube. Install and hand-tighten the collar bolts and lock washers. Ensure the collar bolts are wiped free of grease prior to installation. Torque the collar bolts to 80 lb.-in. maximum.
- Note: Ensure the collar bolts engage in the holes in the tube. If collar bolts do not engage the holes in the tube, the mast can separate during extension.
19. Repeat steps 11 through 18 for each subsequent tube.

7.4.2 Replace Collar Bearing Strips

This section describes replacement of collar bearing strips.

Inspect the bearing strip or wear band (Figure 7-2) and the machined keyways of the collar for wear. If the keyways of the collar are badly worn, the collar should be replaced. If the bearing strips or wear band are worn down to the metal collar, they should be replaced.

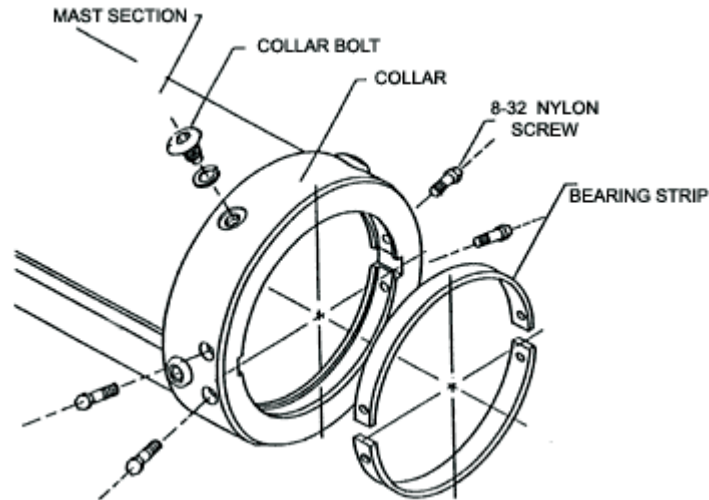

Figure 7-2 Replace Collar Bearing Strips

To replace the bearing strips:

1. Remove the nylon screws from the collar.
2. Pull out the bearing strips and clean the collar.
3. Press the new bearing strips firmly into the groove.
4. Align the holes in the bearing strips with those in the collar.
5. Install and hand-tighten the new nylon screws through the collars into the threaded holes for the bearing strip. Apply Loctite® 495 Instant Adhesive or equivalent to the nylon screws before installation. Do not over tighten the nylon screws.
6. Cut off or file off the ends of the nylon screws protruding through the bearing strips until they are flush.
7. Carefully file off any excess bearing strip that may protrude into the keyway of the collar.
8. Before reassembling the mast, slide each collar over its mating tube. If the collar does not slide freely over the tube, it will be necessary to sand high spots on the bearing strip to fit. The high spots will be evident by shiny or gray marks on the white bearing strip.
9. Wipe the collars clean before reassembling the mast.

7.4.3 Replace Wear Rings

Wear rings are preformed split synthetic bearings that fit around the butt plate above the seal on each interior tube. Wear rings can be replaced when the mast is disassembled for seal replacement. Check the wear rings for wear. If the wear ring is worn down to the butt plate surface, it must be replaced.

To replace the wear rings:

1. Clean the butt plate and wear ring groove (Figure 7-3).

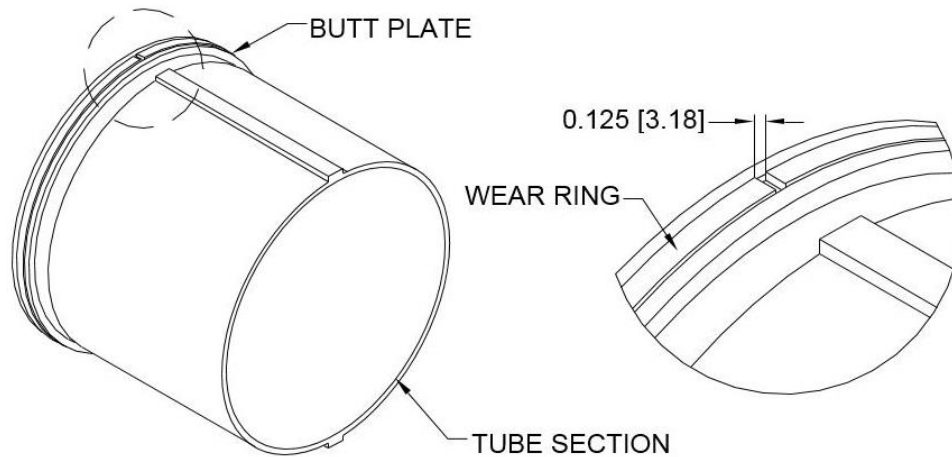

Figure 7-3 Replace Wear Rings

2. Slide the wear ring over the mast and into the groove. Press the wear ring into the groove to make sure there is at least $\frac{1}{8}$ -inch (3.18 mm) clearance between the two ends (Figure 7-3). If necessary, cut enough off one end to get the required gap.
3. The wear ring must be held in place until this tube is inserted into the receiving tube. Apply a bead of adhesive inside the groove on the butt plate to bond the wear ring in place. If the wear ring prevents the tube from sliding inside the next tube, lightly grind the wear ring OD as necessary.
4. Before reassembling the tubes, slide each tube inside its mating tube. If the smaller tube does not slide freely inside the next largest tube, it will be necessary to sand high spots on the wear ring to fit. The high spots will appear as shiny or discolored marks on the outside diameter of the wear ring.

7.4.4 Replace Internal Bumpers

The internal bumper, which looks like an o-ring, is located on the top edge of the stop panel on each internal tube. When the mast is disassembled, check the condition of the internal bumper. If the internal bumper has deteriorated, it should be replaced.

To replace the internal bumper:

1. Remove the old internal bumper.
2. Carefully stretch the new internal bumper over the end of the tube and insert it into the groove machined in the keys. The internal bumper should fit tightly against the tube immediately above the stop panel (Figure 7-4).

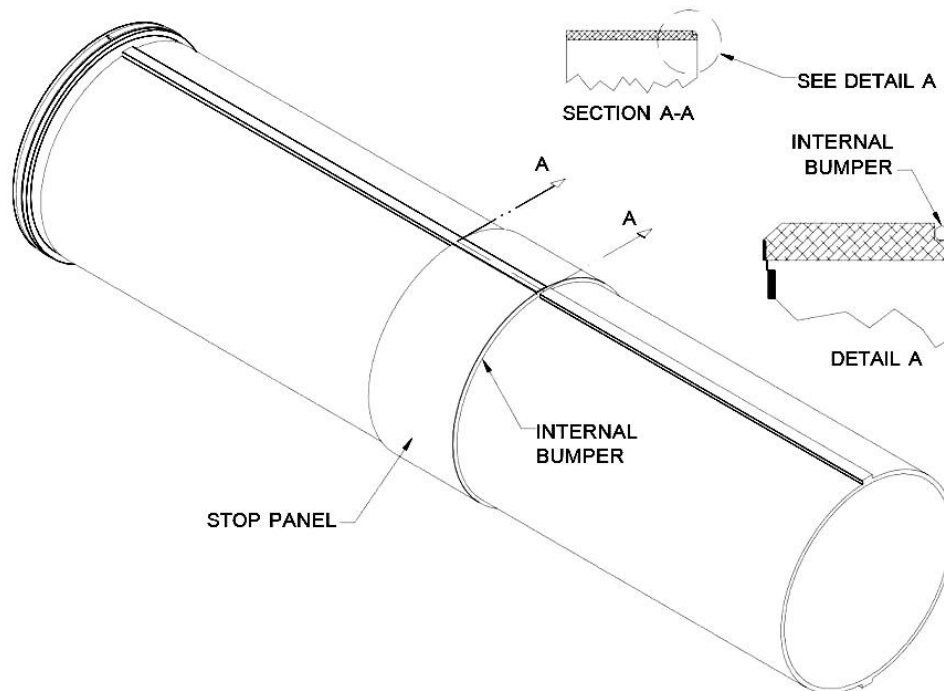

Figure 7-4 Replace Internal Bumpers

7.4.5 Replace External Bumpers

The external bumper is a flat rubber ring cemented to the top of each mast collar. Check the condition and the adhesion of each external bumper. If the external bumpers become loose, they can usually be reused unless they have been damaged.

To replace the external bumpers:

1. Remove the old external bumper.
2. Use acetone to clean off any old adhesive from the collar. Clean the replacement bumper with acetone. Allow it to dry thoroughly.
3. At room temperature, apply a light bead of Loctite® Black Max Adhesive 380 or equivalent around the top of the collar. Follow the manufacturer's instructions.
4. Place the external bumper on the collar and align the inside diameter edges. Hold pressure on the external bumper and collar using a uniform weight for at least 90 seconds.
5. Using a razor knife, notch out keyways in the external bumper to match those in the collar (Figure 7-5).

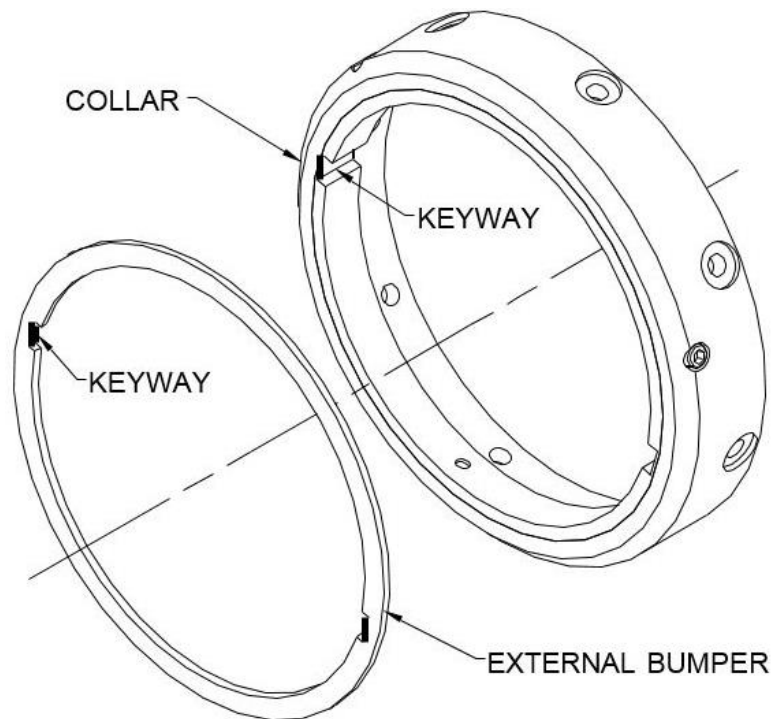

Figure 7-5 Replace External Bumpers

7.5 Long-Term Storage

When putting the system into long-term storage, ensure the:

- Mast is fully nested (Section 5.3).
- Drain cock is open to eliminate the possibility of inadvertent mast extension.
- Mast is stored in a clean and dry environment.
- Mast is stored vertically when storing for more than six months with provisions to keep the mast from tipping over.
- Mast is extended and lowered every six months (Section 5).

7.6 System Disposal

Dispose of the mast in accordance with the national environmental regulations.

(This page is intentionally left blank.)

Section 8 Troubleshooting

This section describes troubleshooting for the mast system. Use care to understand and follow all precautions while troubleshooting the mast system.

Table 8-1 Troubleshooting

Problem	Possible Cause(s)	Possible Solutions
Mast frozen in extended position		
	Base tube not drained routinely. Typically freezes around collar area.	<ol style="list-style-type: none"> 1. Wrap warming blankets around collar until ice melts. Use heat gun or 500W quartz light. 2. Depressurize mast. Inject 1 oz. Will-Burt Antifreeze (P/N: 4735801), suited for aluminum engines, where top of collar and intermediate tube meet.
Mast frozen in nested position		
	Base tube not drained routinely. Typically damages tubes.	Send to manufacturer for repair or replacement.
Mast will not lower without rocking		
	Mast not oiled in extreme conditions.	See Section 7.3 for mast cleaning and lubrication.
	Not enough weight.	Add weight to platform or stub adapter.
	Bent tube.	Check tube trueness. If bent, order replacement.
	Broken internal bumper.	Depressurize mast. Remove the collar and lift the tube to check the internal bumper. If necessary, order replacement.
	Collar inserts tight.	Depressurize and disassemble mast. File or lightly grind to pre-fit collar inserts as necessary.
Largest intermediate tube section stuck		
	Internal mount bracket too tight.	Loosen bolts. Shim as necessary between clamp halves.
Rotational movement in mast sections		
	Bearing strips or inserts worn.	<ol style="list-style-type: none"> 1. Locking strip collar: Order new bearing strips. Customer must pre-fit. 2. Non-locking Insert Collar: Order Insert. Customer must pre-fit.
For additional information, please contact The Will-Burt Company's Customer Service at +1 330 684 4000.		

(This page is intentionally left blank.)