

REVISION HISTORY				
ECN	REV	DESCRIPTION	DATE	BY/APPR
12135	S	RESTRUCTURED BOM	4/23/2014	RCC
12580	T	CHANGED NOTE TWO TO REFERENCE DRAWING WD-46276	3/31/2015	KWBH

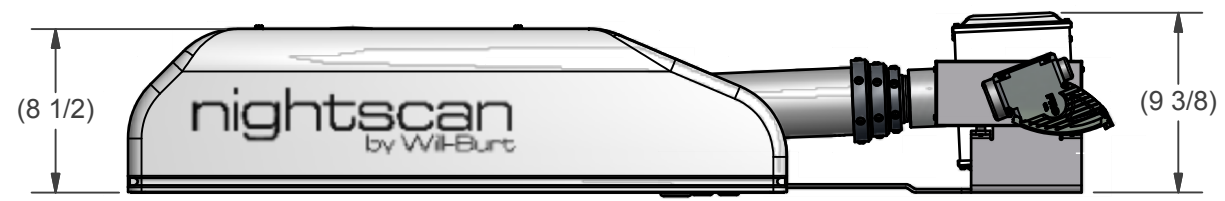
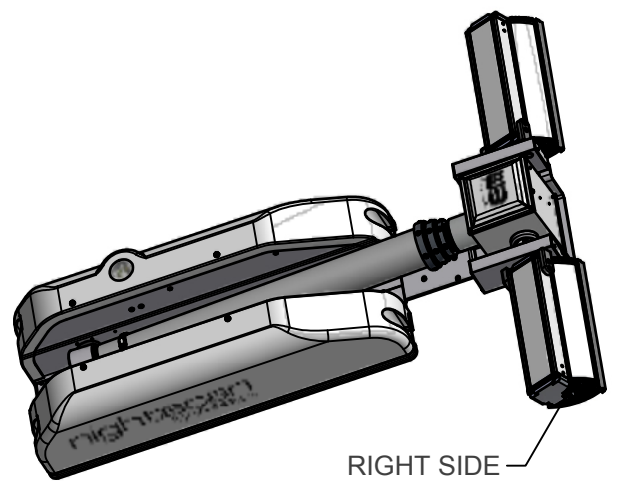

BOM			
ITEM	QTY	PART NUMBER	DESCRIPTION
1	1	4522001	BASE ASSEMBLY, 7.5 CLR
2	1	4548301	NSC RCP, LIGHTS ONLY
3	1	4573509	OPT 2 LIGHT, 2000W (2-1000W 220VAC) WHT
4	1	4558901	NSC LABEL KIT CE (NOT SHOWN)
5	1	TP-4602001	NS CHIEF 1.8/2.3 OPERATOR'S MANUAL (NOT SHOWN)

- NOTES:
- 1 APPLY RTV #739 OR EQUAL TO ALL OPEN HOLES.
 - 2 SEE WIRING DIAGRAM WD-46276 FOR ALL UNITS.
 - 3 SET LIGHT BARS HOME POSITION PARALLEL TO BASE PLATE WHEN STOWED.

UNLESS OTHERWISE SPECIFIED DIMENSIONS ARE IN INCHES.

TOLERANCES ON DECIMALS ANGLES
 0 = ± 0.030 ± 1/2°
 00 = ± 0.010
 000 = ± 0.005

FRACTIONAL ± 1/64"
 1. ALL INSIDE EDGES TO HAVE .005" TO .035" FILLETS.
 2. ALL OUTSIDE EDGES TO HAVE .005" TO .015" CHAMFER OR RADIUS.

125° ON ALL MACHINED SURFACES

APPROX. WT: 93.93 lbmass

THIRD ANGLE PROJECTION

PROPRIETARY AND CONFIDENTIAL
 THE INFORMATION CONTAINED IN THIS DRAWING IS THE SOLE PROPERTY OF THE WILL-BURT COMPANY ANY REPRODUCTION IN PART OR WHOLE WITHOUT THE WRITTEN PERMISSION OF THE WILL-BURT COMPANY IS PROHIBITED.

APPROVALS	DATE
DRAWN RCC	4/23/2014
CHECKED	

WILL-BURT AN EMPLOYEE OWNED COMPANY
 ORRVILLE, OH

TITLE
**NS 2.3 2000 2X1000W
 OPT-220V WHT**

SIZE B	DWG NO 720767041	REV T
PN: SEE TABLE	SHEET 1 OF 2	

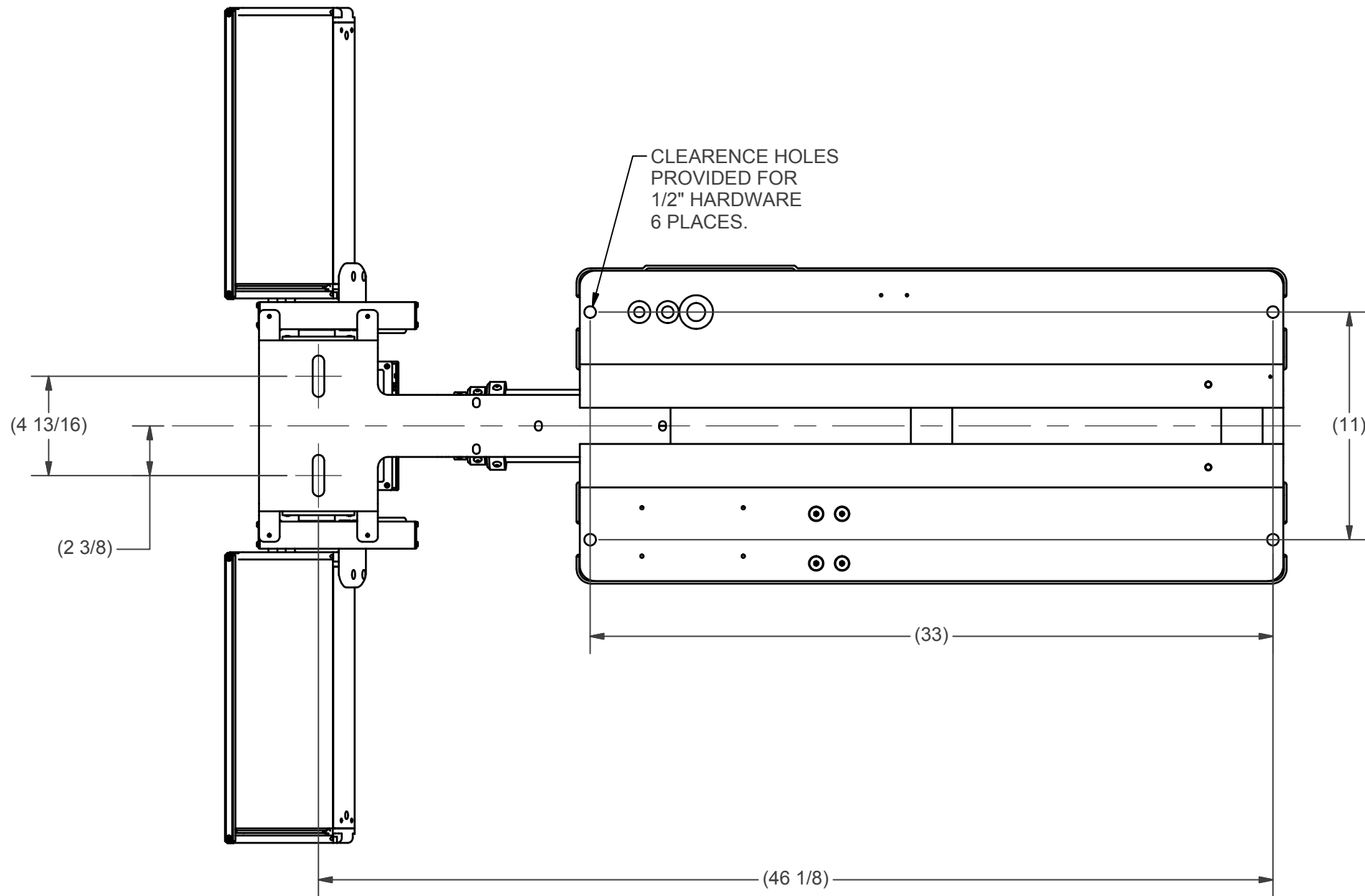

MOUNTING (BOLT PATTERN)

APPROX. WT: 93.93 lbmass

THIRD ANGLE PROJECTION



UNLESS OTHERWISE SPECIFIED
DIMENSIONS ARE IN INCHES.

TOLERANCES ON DECIMALS	ANGLES
0 = ± 0.030	± 1/2°
00 = ± 0.010	
000 = ± 0.005	
FRACTIONAL ± 1/64"	
1. ALL INSIDE EDGES TO HAVE .005" TO .035" FILLETS.	
2. ALL OUTSIDE EDGES TO HAVE .005" TO .015" CHAMFER OR RADIUS.	

125° ON ALL MACHINED SURFACES

PROPRIETARY AND CONFIDENTIAL
THE INFORMATION CONTAINED IN THIS
DRAWING IS THE SOLE PROPERTY OF THE
WILL-BURT COMPANY ANY REPRODUCTION
IN PART OR WHOLE WITHOUT THE WRITTEN
PERMISSION OF THE WILL-BURT COMPANY IS
PROHIBITED.

WB AN EMPLOYEE OWNED COMPANY
WILL-BURT ORRVILLE, OH

TITLE
**NS 2.3 2000 2X1000W
OPT-220V WHT**

APPROVALS	DATE
DRAWN RCC	4/23/2014
CHECKED	

SIZE B	DWG NO 720767041	REV T
PN: SEE TABLE	SHEET 2 OF 2	