

ASSEMBLY NO	DESCRIPTION	ITEM-2 P/N	ITEM-3 P/N	ITEM-4 P/N
720649041	NS 1.8-6000-4 OPT-220V WHITE	4548301	4574601	NONE
720671041	NS 1.8-3600-4 OPT-220V WHITE	4548301	4574605	NONE
720649042	NS 1.8-6000-4 OPT. 220V w/ RED STROBE	4548305	4574601	4481602

REVISION HISTORY				
ECN	REV	DESCRIPTION	DATE	BY/APPR
10512	A	INITIAL RELEASE	5/2/2011	SMB\
10563	B	Remove 720681041 assembly Obsolete	6/3/2011	RCC\
10703	C	Added 720649042 Assembly	9/12/2011	RCC\

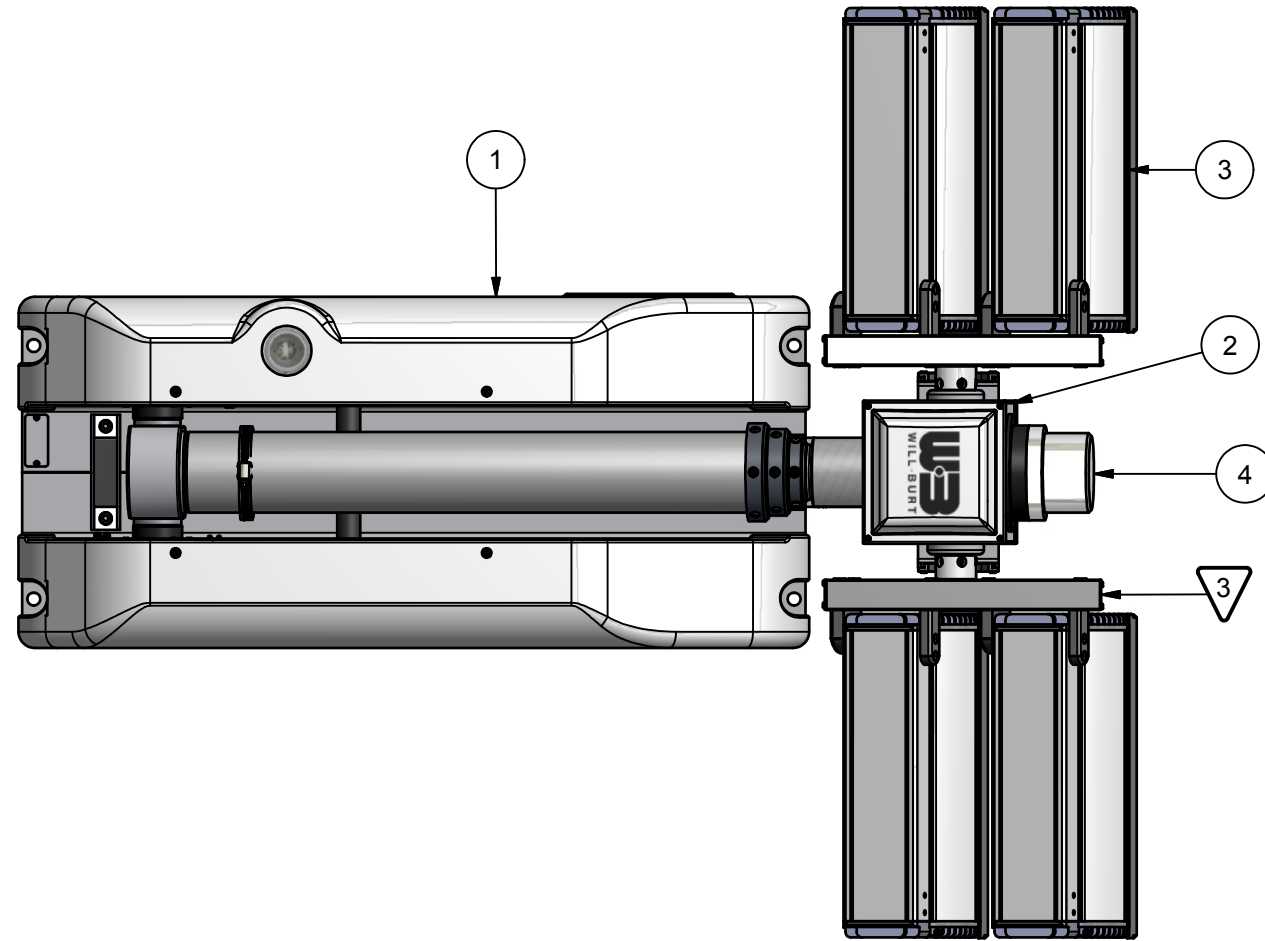

- NOTES:
- 1 APPLY RTV #739 OR EQUAL TO ALL OPEN HOLES.
 - 2 SEE WIRING DIAGRAM 46066 FOR ALL UNITS.
 - 3 SET LIGHT BARS HOME POSITION PARALLEL TO BASE PLATE WHEN STOWED.

BOM				
ITEM	QTY	PART NUMBER	DESCRIPTION	
1	1	4522003	NSC BASE ASSEMBLY 6.0 WHITE	
2	1	SEE TABLE	NSC RCP,	
3	1	SEE TABLE	LIGHT KIT	
4	1	SEE TABLE	Light, Strobe Kit	
5	1	4558901	NSC LABEL KIT (NOT SHOWN)	
6	1	900600	MAST OIL (SHIP LOOSE) (NOT SHOWN)	
7	1	TP-4602001	MANUAL, NS 1.8/2.3, CE, CD VERSION (NOT SHOWN)	
8	1	4584001	FILLER, CORRUGATED NSC (NOT SHOWN)	

UNLESS OTHERWISE SPECIFIED DIMENSIONS ARE IN INCHES.
TOLERANCES ON DECIMALS ANGLES
0 = ± 0.030 ± 1/2°
.00 = ± 0.010
.000 = ± 0.005
FRACTIONAL ± 1/64"
1. ALL INSIDE EDGES TO HAVE
.005" TO .035" FILLETS.
2. ALL OUTSIDE EDGES TO HAVE
.005" TO .015" CHAMFER OR RADIUS.
125° ON ALL MACHINED SURFACES

APPROX. WT:N/A
THIRD ANGLE PROJECTION

PROPRIETARY AND CONFIDENTIAL
THE INFORMATION CONTAINED IN THIS DRAWING IS THE SOLE PROPERTY OF THE WILL-BURT COMPANY ANY REPRODUCTION IN PART OR WHOLE WITHOUT THE WRITTEN PERMISSION OF THE WILL-BURT COMPANY IS PROHIBITED.

APPROVALS	DATE
DRAWN SMB	5/2/2011
CHECKED	

WILL-BURT AN EMPLOYEE OWNED COMPANY
ORRVILLE, OH

TITLE
NS 1.8-6000-4 OPT-220V WHITE

SIZE B	DWG NO 720649041	REV C
PN: SEE TABLE ABOVE		SHEET 1 OF 2

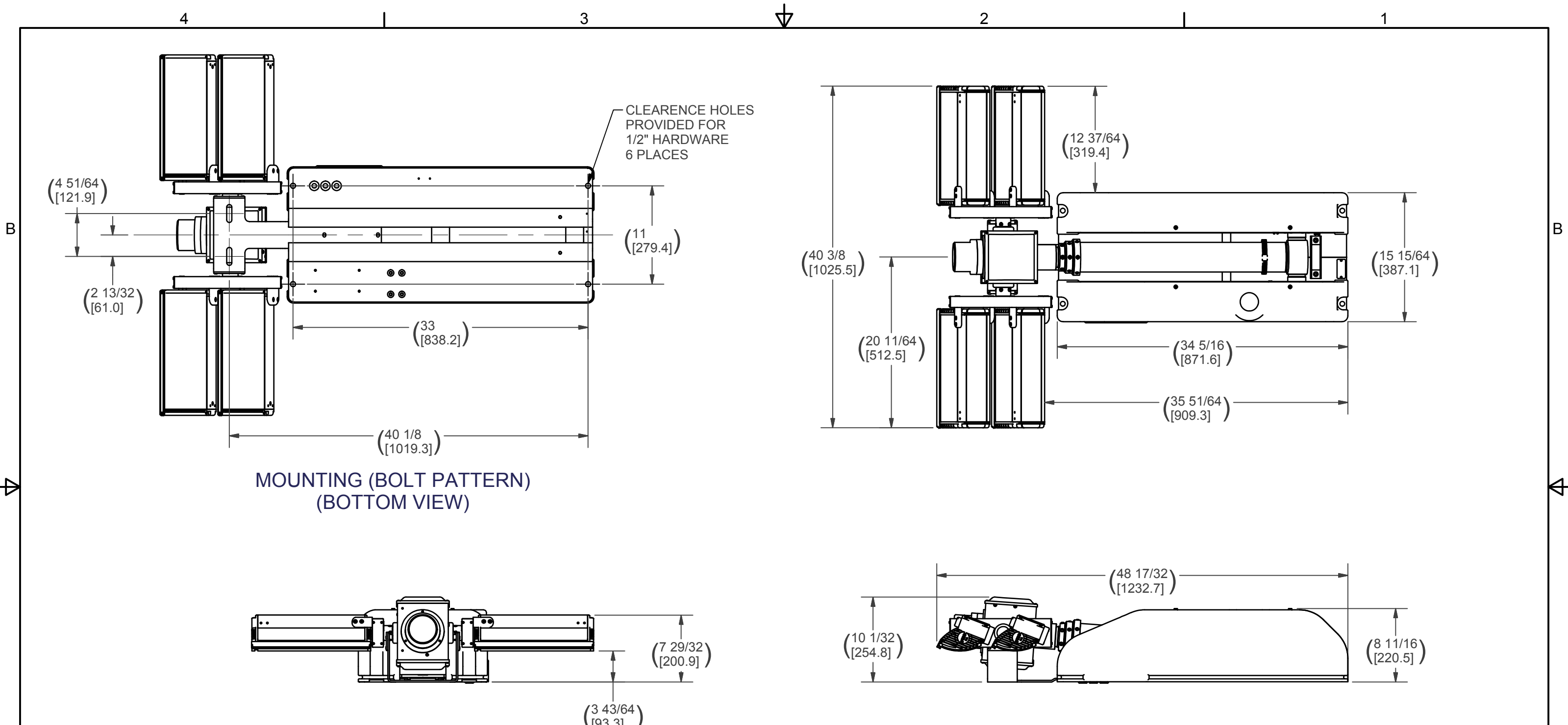

ALL SPECIFICATIONS SUBJECT TO CHANGE WITHOUT NOTICE.

NOTES:
PRIMARY DIMENSIONS INCHES
SECONDARY DIMENSIONS MILLIMETERS

APPROX. WT:N/A
THIRD ANGLE PROJECTION

UNLESS OTHERWISE SPECIFIED DIMENSIONS ARE IN INCHES. TOLERANCES ON DECIMALS ANGLES 0 = ± 0.030 ± 1/2° .00 = ± 0.010 .000 = ± 0.005 FRACTIONAL ± 1/64" 1. ALL INSIDE EDGES TO HAVE .005" TO .035" FILLETS. 2. ALL OUTSIDE EDGES TO HAVE .005" TO .015" CHAMFER OR RADIUS. $\sqrt[125]{}$ ON ALL MACHINED SURFACES		PROPRIETARY AND CONFIDENTIAL THE INFORMATION CONTAINED IN THIS DRAWING IS THE SOLE PROPERTY OF THE WILL-BURT COMPANY ANY REPRODUCTION IN PART OR WHOLE WITHOUT THE WRITTEN PERMISSION OF THE WILL-BURT COMPANY IS PROHIBITED.		AN EMPLOYEE OWNED COMPANY ORRVILLE, OH	
APPROVALS DRAWN SMB CHECKED		DATE 5/2/2011		TITLE NS 1.8-6000-4 OPT-220V WHITE	SIZE B
		DWG NO 720649041		REV C	
		PN: SEE TABLE ABOVE		SHEET 2 OF 2	