

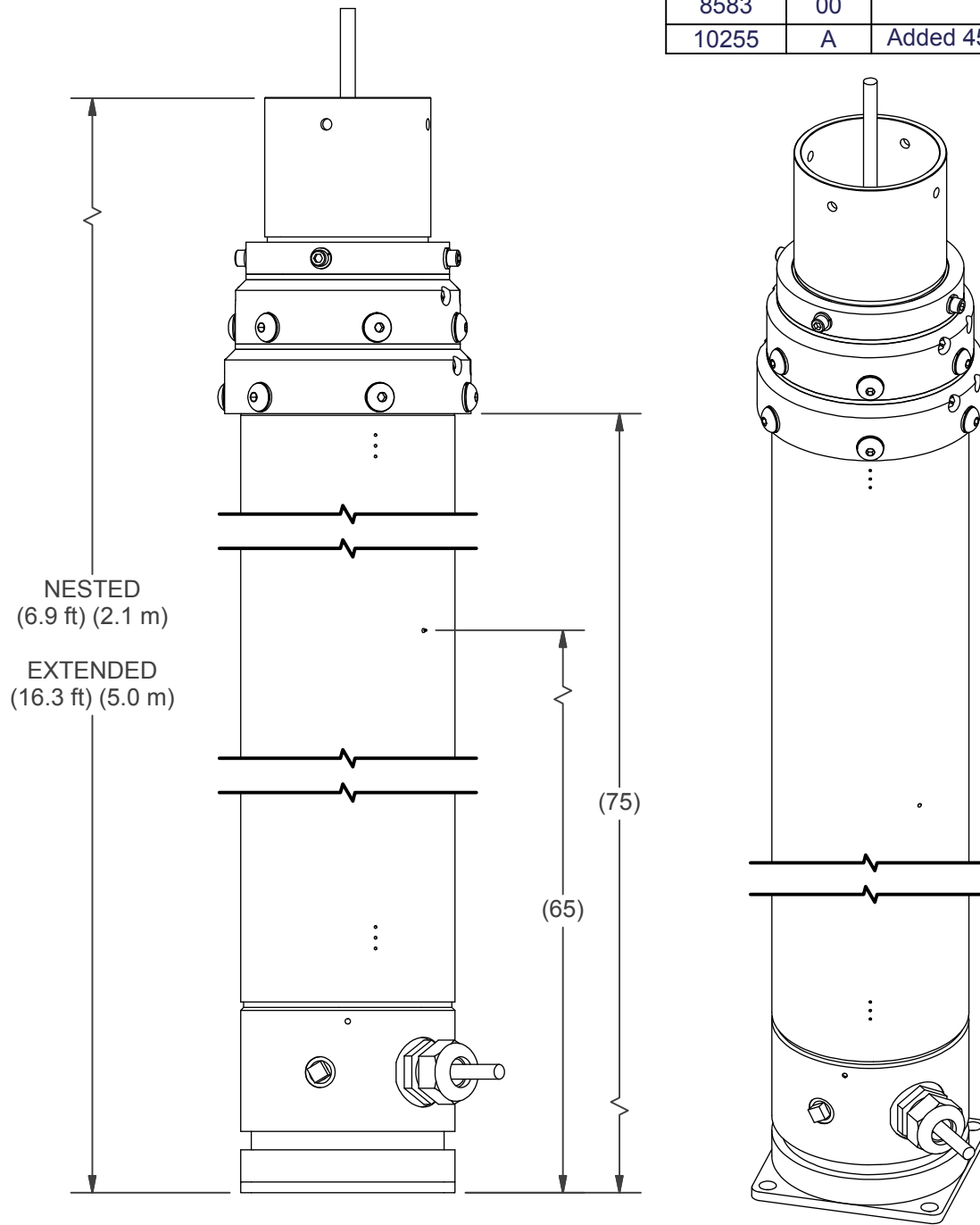

REVISION HISTORY				
ECN	REV	DESCRIPTION	DATE	BY/APPR
8583	00	INITIAL RELEASE	1/5/2007	KN/
10255	A	Added 4530603, Removed 901655, 914170	10/4/2010	CJM/



NOTES:

- 1 TO INSTALL MAST DRAIN KIT, FOLLOW PROCEDURE ON SERVICE SHEET #414 EXCEPT USE TWO WASHERS INSTEAD OF ONE.
- 2 LEVEL THE I.D. PLATE WITH THE AIR PORT ON THE BASE MAST SECTION. USE THE ID PLATE AND MATCH DRILL (2) Ø.104 HOLES x .28. DO NOT DRILL THRU. USE (2) DRIVE SCREWS AND ATTACH THE ID PLATE TO THE BASE MAST SECTION.
- 3 APPLY LOCTITE #380 OR EQUAL.
- 4 ALIGN COLLAR KEYWAY WITH SCRIBE LINE ON BASE TUBE.
- 5 TORQUE COLLAR BOLTS TO 100-120 IN/LBS.
- 6 ASSEMBLE TUBES WITH WEEP HOLES CLOSEST TO COLLARS.

MATERIAL SEE BOM	UNLESS OTHERWISE SPECIFIED DIMENSIONS ARE IN INCHES. TOLERANCES ON DECIMALS ANGLES 0 = .0060 .1/2- 00 = .0030 000 = .0005 FRACTIONAL 1/64" 1. ALL INSIDE EDGES TO HAVE .005" TO .035" FILLETS. 2. ALL OUTSIDE EDGES TO HAVE .005" TO .015" CHAMFER OR RADIUS. 125 ON ALL MACHINED SURFACES	PROPRIETARY AND CONFIDENTIAL THE INFORMATION CONTAINED IN THIS DRAWING IS THE SOLE PROPERTY OF THE WILL-BURT COMPANY ANY REPRODUCTION IN PART OR WHOLE WITHOUT THE WRITTEN PERMISSION OF THE WILL-BURT COMPANY IS PROHIBITED.	 AN EMPLOYEE OWNED COMPANY ORRVILLE, OH			
			TITLE 7-16-1XX IWM			
FINISH REF: BLACK HARDCOAT WITH TEFLON		APPROVALS	DATE	SIZE	DWG NO	REV
APPROX. WT: LB		DRAWN kneidig	1/5/2007	B	710101690	A
THIRD ANGLE PROJECTION		CHECKED		PN: 710101690	SHEET 1 OF 2	