

WIRELESS J-BOX ONLY

4184601 NFPA WIRELESS J-BOX ³
 KIT 4735007
 KIT 4735009

4184602 STANDARD WIRELESS J-BOX ⁴
 KIT 4735015
 KIT 4735016

REVISIONS				
ECN	REV	DESCRIPTION	DATE	BY/APPVL
10617	00	NEW	09-01-11	DJB/JMK

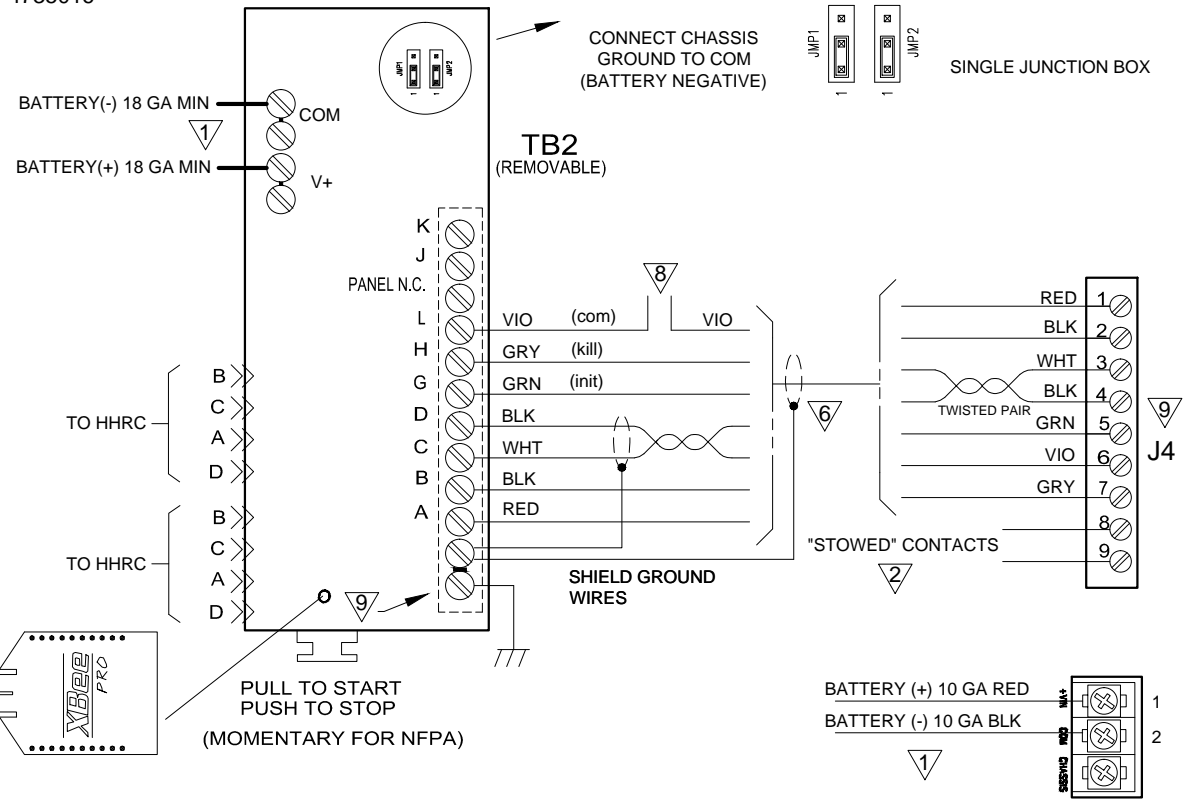
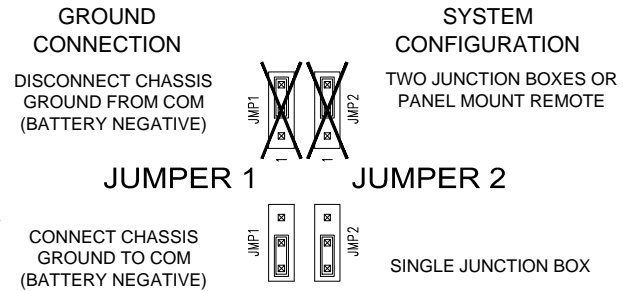

NOTES

- CUSTOMER SUPPLIED WIRING. TORQUE: 20 in-lbs, 2.3Nm
- USE SW2-1 ON BASE BOARD TO SELECT OPEN (OFF) OR CLOSED (ON) WHEN NESTED.
 SW2-1 OPEN = CONTACTS CLOSED WHEN NESTED
 SW2-1 CLOSED = CONTACTS OPEN WHEN NESTED.
 2 AMPS MAX CURRENT, 20 GA. MINIMUM CONDUCTOR.
- SW2-2 ON BASE BOARD MUST BE OPEN (OFF) FOR NFPA MODE.
- SW2-2 ON BASE BOARD MUST BE CLOSED (ON) STANDARD MODE.
- REMOVE JUMPER(S) IF REPLACED BY PARKING BRAKE INTERLOCK. G-H CLOSED WHEN BRAKE "ON".
 AVAILABLE IN STANDARD MODE ONLY.
- 4521801 (50 FT. CABLE) ALL WIRES 20 GA. EXCEPT RED AND BLACK (J4-1 AND 2).
- 4032102 (50 FT. CABLE) ALL WIRES 20 GA. EXCEPT RED AND BLACK (J4-1 AND 2).
- OPTIONAL DISABLE INPUT, CUSTOMER SUPPLIED CONTACTS. MUST HAVE CONTINUITY TO FUNCTION. WILL NOT ALLOW OPERATION IF OPEN, ACTS AS EMERGENCY STOP.
- 4.4in-lbs, 0.5Nm

AutoCAD Drawing: NS Universal J-Box Wiring.dwg	UNLESS OTHERWISE SPECIFIED DIMENSIONS ARE IN INCHES	THIS DOCUMENT CONTAINS PROPRIETARY INFORMATION AND SHALL NOT BE USED OR REPRODUCED OR ITS CONTENTS DISCLOSED IN WHOLE OR IN PART, WITHOUT THE PRIOR WRITTEN CONSENT OF THE WILL-BURT COMPANY.	WB AN EMPLOYEE OWNED COMPANY ORRVILLE, OHIO
FINISH	TOLERANCES ON: DECIMALS ANGLES 0 = ± 1/2" 00 = ± 000 = ±	FOR LOGISTICAL SUPPORT ONLY	DESC. nightscan™ UNIVERSAL CONTROL ROOF-MOUNT, NFPA OR STANDARD WIRELESS J-BOX
	FRACTIONS ±	SIGNATURE	DATE
	BREAK ALL SHARP CORNERS 125° ON ALL MACHINED SURFACES	DR. BY DJB	
		CK. BY JDN	
		APP. BY	
		SIZE B	DWG. No. WD-72207
		SCALE NTS	SHEET 1 OF 1