

REVISIONS				
ECN	REV	DESCRIPTION	DATE	BY/APPVL
10207	00	NEW	09-07-10	DJB/JDN

# STANDARD J-BOX 3

KIT 4236704

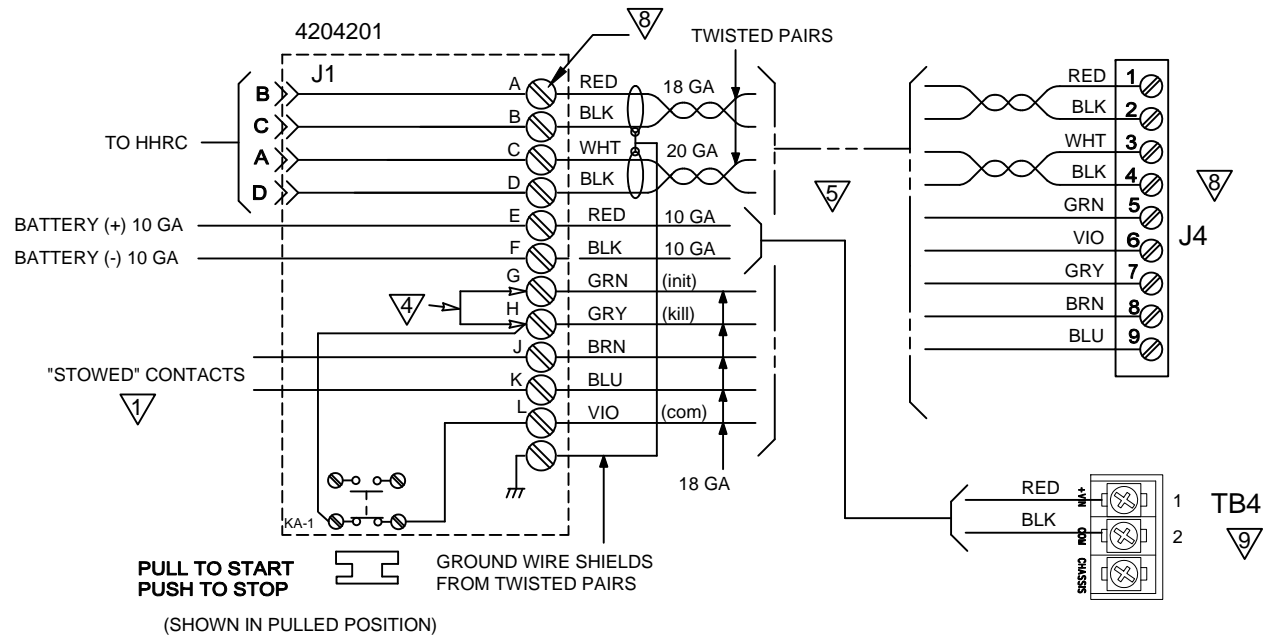

## NOTES

- USE SW2 POSITION 1 ON BASE BOARD TO SELECT OPEN OR CLOSED WHEN NESTED.  
(SOFTWARE 6.3 AND HIGHER)  
SW2-1 OPEN = CONTACTS CLOSED WHEN NESTED  
SW2-1 CLOSED = CONTACTS OPEN WHEN NESTED.  
2 AMPS MAX CURRENT, 20 GA. MINIMUM CONDUCTOR.
- SW2 POSITION 2 ON BASE BOARD MUST BE OPEN (NFPA MODE)
- SW2 POSITION 2 ON BASE BOARD MUST BE CLOSED (STANDARD MODE)
- REMOVE JUMPER(S) IF REPLACED BY PARKING BRAKE INTERLOCK. G-H CLOSED WHEN BRAKE "ON".  
AVAILABLE IN STANDARD MODE ONLY.
- VERTICAL: 4032502 (30 FT. CABLE), 4032503 (50 FT. CABLE)  
ROOF-MOUNT: 4032505 (30 FT. CABLE), 4032506 (50 FT. CABLE)
- 4032101 (20 FT. CABLE), 4032102 (50 FT. CABLE)
- OPTIONAL DISABLE INPUT, CUSTOMER SUPPLIED CONTACTS. MUST HAVE CONTINUITY TO FUNCTION. WILL NOT ALLOW OPERATION IF OPEN, ACTS AS EMERGENCY STOP.
- 4.4in-lbs, 0.5Nm
- 20 in-lbs, 2.3Nm

<b>AutoCAD Drawing:</b> NS J-Box Wiring.DWG	UNLESS OTHERWISE SPECIFIED DIMENSIONS ARE IN INCHES  TOLERANCES ON: DECIMALS ANGLES 0 = ± ± 1/2" 00 = ± ± 000 = ± ±  FRACTIONS ±  BREAK ALL SHARP CORNERS 1/32" ON ALL MACHINED SURFACES	THIS DOCUMENT CONTAINS PROPRIETARY INFORMATION AND SHALL NOT BE USED OR REPRODUCED OR ITS CONTENTS DISCLOSED IN WHOLE OR IN PART, WITHOUT THE PRIOR WRITTEN CONSENT OF THE WILL-BURT COMPANY.  FOR LOGISTICAL SUPPORT ONLY SIGNATURE DATE DR.BY DJB - CK.BY JDN - APP.BY	<b>WILL-BURT</b> AN EMPLOYEE OWNED COMPANY ORRVILLE, OHIO  NEXT ASSY DESC. NIGHTSCAN CHIEF ROOF-MOUNT STANDARD <b>SINGLE HARD-WIRED J-BOX</b>  SIZE DWG. No. <b>B</b> <b>WD-72003</b>  SCALE NTS SHEET 1 OF 1
--	--	---	---