

REVISIONS				
ECN	REV	DESCRIPTION	DATE	BY/APPVL
11742	B	ADD K1 FOR EXHAUST/HOLD VALVE SIGNAL REVERSAL, ADD OPTIONAL COMPRESSOR & VALVE ASM.	08-16-13	DJB/JLK
11867	C	ADD 24 TO 12V CONVERTER, SIMPLIFY OPT.COMP. WIRING	11-07-13	DJB
11963	D	CLARIFY WIRING	01-23-14	DJB
12157	E	COMP. SUB-ASSY REPLACED BY STD. COMPRESSOR	05-07-14	DJB
12738	F	CLARIFY K1 WIRING DETAILS	05-26-15	DJB/TH
12797	G	ADD OPTIONAL DC COMPRESSOR	07-09-15	DJB
13205	H	ADD ALTERNATE WIRE COLORS FOR HHRC	04-26-16	DJB/AW

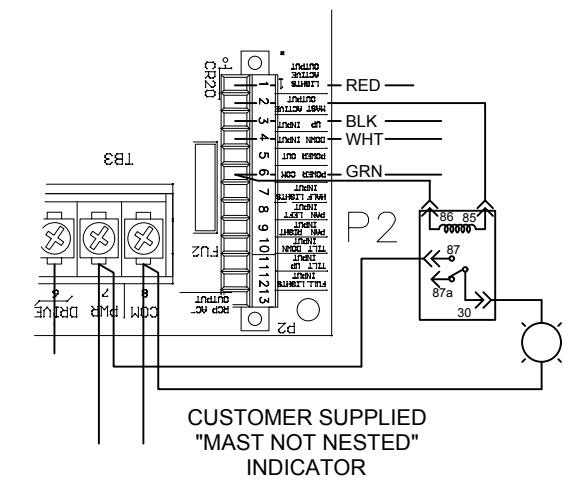
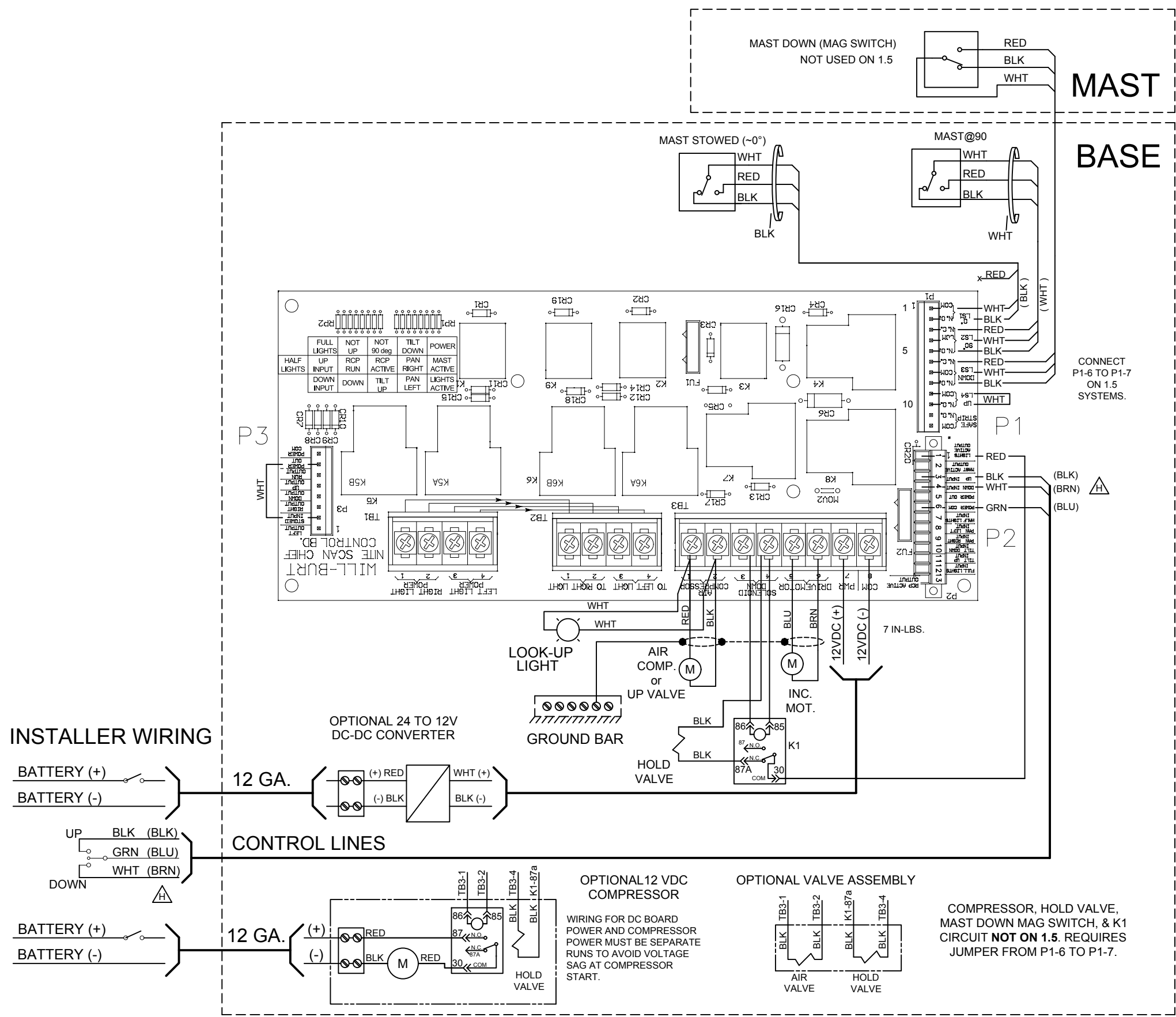

MATERIAL 901102 NSU.DWG	UNLESS OTHERWISE SPECIFIED DIMENSIONS ARE IN INCHES TOLERANCES ON: DECIMALS ANGLES 0 ± ± 1/2" 00 ± ± 000 ± ± FRACTIONS ± BREAK ALL SHARP CORNERS ON ALL MACHINED SURFACES	THIS DOCUMENT CONTAINS PROPRIETARY INFORMATION AND SHALL NOT BE USED OR REPRODUCED IN WHOLE OR IN PART, WITHOUT THE PRIOR WRITTEN CONSENT OF THE WILL-BURT COMPANY. FOR LOGISTICAL SUPPORT ONLY SIGNATURE DATE DR. BY DJB 08-07-12 CK. BY JMK APP. BY	AN EMPLOYEE OWNED COMPANY ORRVILLE, OHIO WILL-BURT NEXT ASSY DESC. INFLXION SERIES WITH 901102 CONTROL BASE WIRING SIZE DWG. No. B WD-4833201 SCALE NTS SHEET 1 OF 1
----------------------------	---	--	--