

REVISION HISTORY				
ECN	REV	DESCRIPTION	DATE	BY/APPR
12371	00	INITIAL RELEASE	9/15/2014	RCC

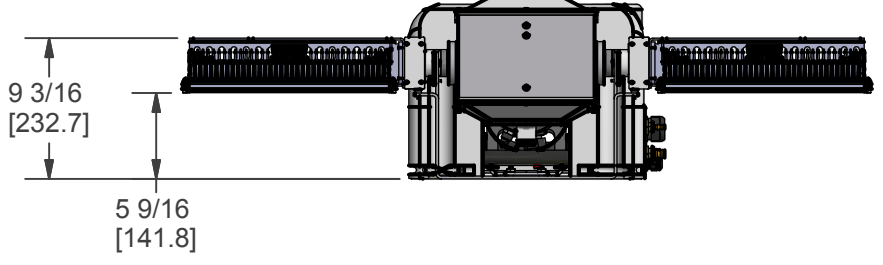
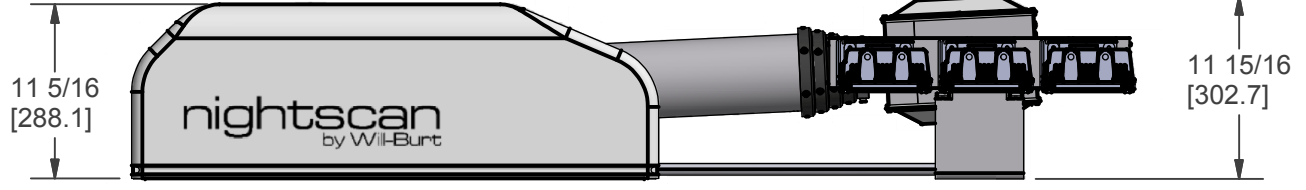
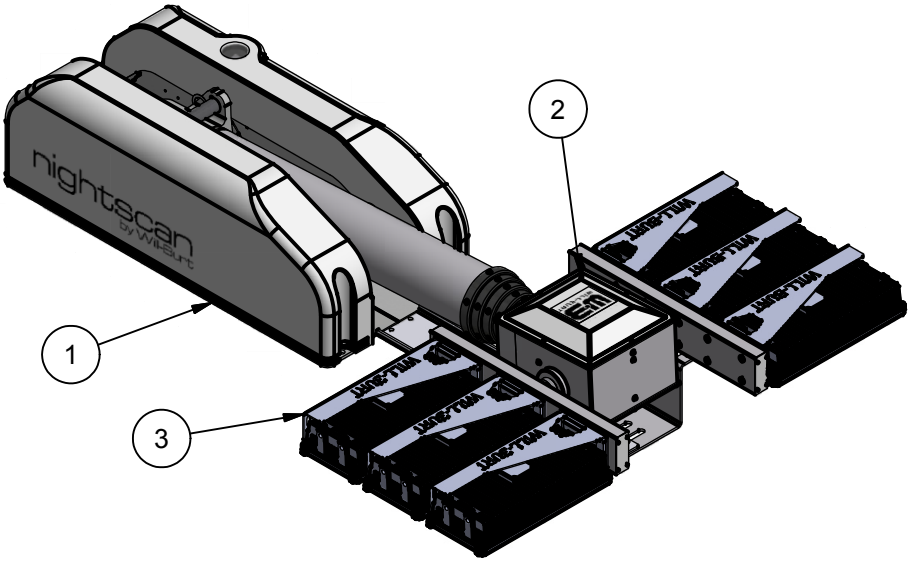
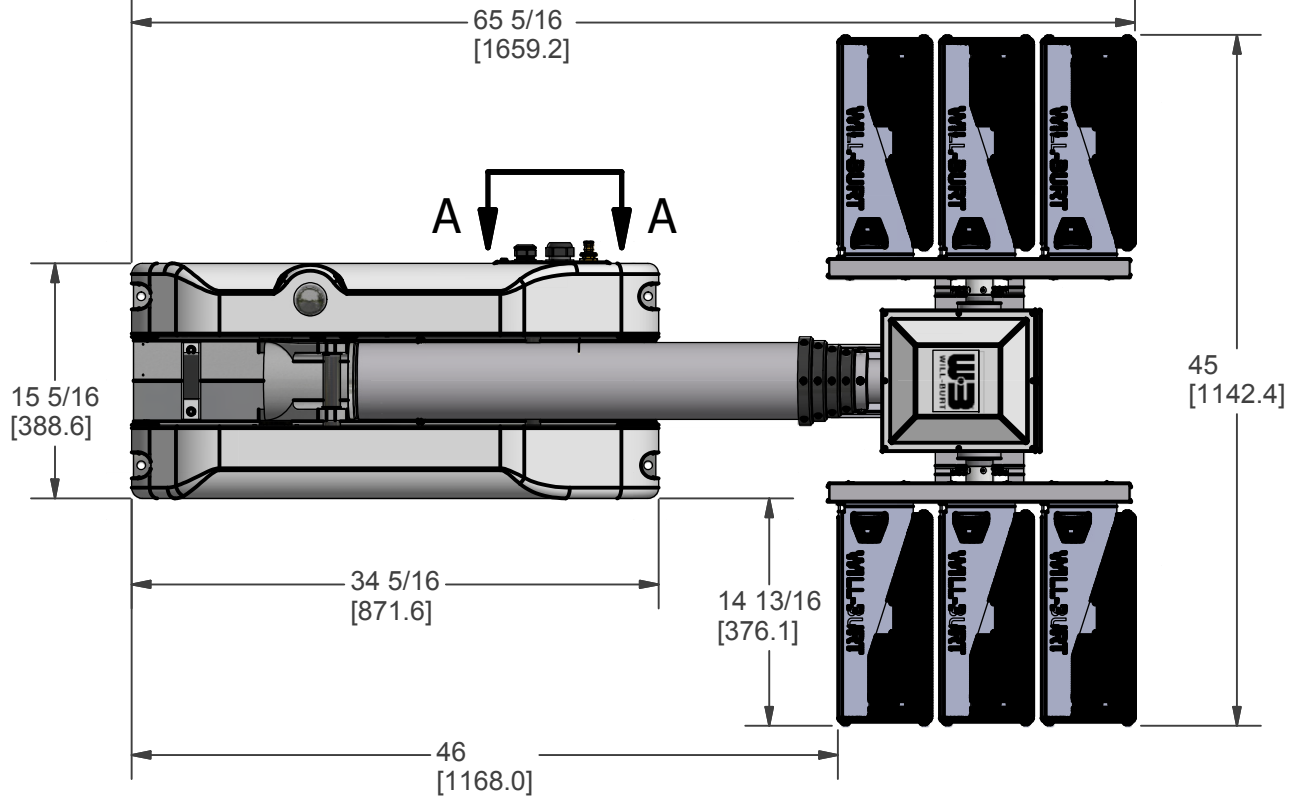

NOTES:  
SECONDARY DIMENSIONS - MILLIMETERS NOTED IN BRACKETS

APPROX. WT:180.3 lbmass

THIRD ANGLE PROJECTION



**UNLESS OTHERWISE SPECIFIED DIMENSIONS ARE IN INCHES.**  
TOLERANCES ON DECIMALS ANGLES  
0 = ± 0.030 ± 1/2°  
.00 = ± 0.015  
.000 = ± 0.010  
FRACTIONAL ± 1/64"  
1. ALL INSIDE EDGES TO HAVE .005" TO .035" FILLETS.  
2. ALL OUTSIDE EDGES TO HAVE .005" TO .015" CHAMFER OR RADIUS.  
125√ ON ALL MACHINED SURFACES

**PROPRIETARY AND CONFIDENTIAL**  
THE INFORMATION CONTAINED IN THIS DRAWING IS THE SOLE PROPERTY OF THE WILL-BURT COMPANY ANY REPRODUCTION IN PART OR WHOLE WITHOUT THE WRITTEN PERMISSION OF THE WILL-BURT COMPANY IS PROHIBITED.

**WB** AN EMPLOYEE OWNED COMPANY  
WILL-BURT ORRVILLE, OH

TITLE  
**NS 3.0 1080W 6x180 WHL  
120V SPT/FLD WHT**

APPROVALS	DATE
DRAWN RCC	9/15/2014
CHECKED	

SIZE	DWG NO	REV
B	721030020	00
PN: 721030020		SHEET 1 OF 2

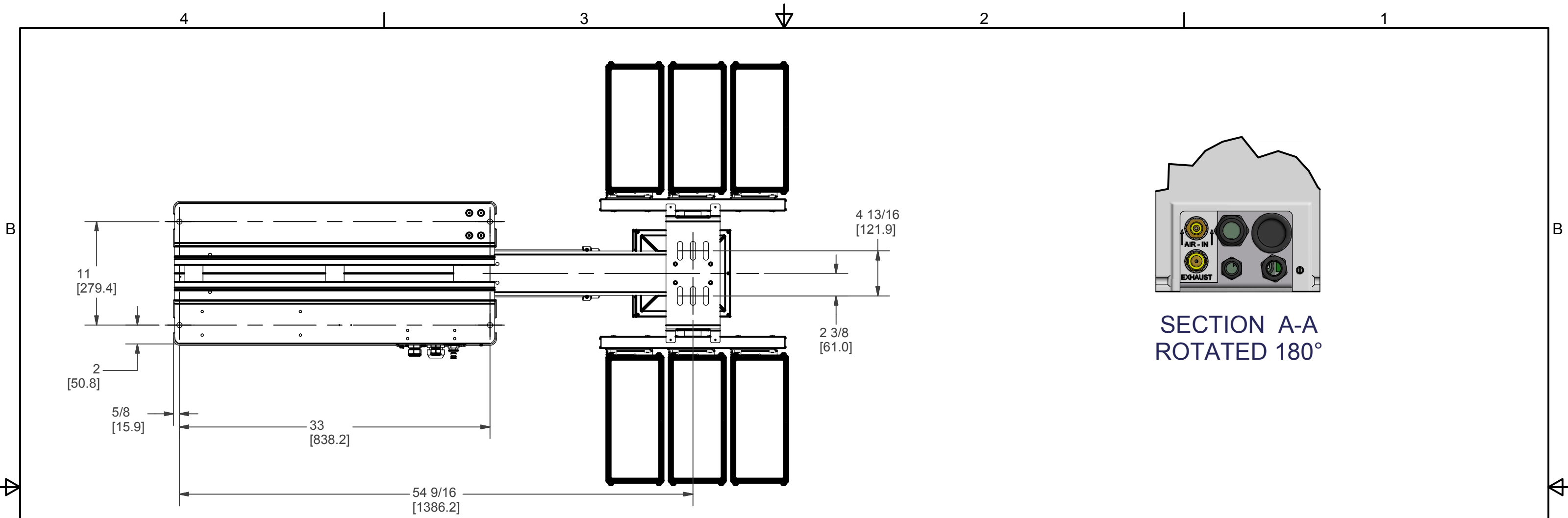

BOTTOM VIEW  
MOUNTING BOLT PATTERN

NOTES:

- 1 APPLY RTV #739 OR EQUAL TO ALL OPEN HOLES
- 2 SEE WIRING DIAGRAM WD-46276 FOR WIRING DETAILS
- 3 SET LIGHT BARS HOME POSITION PARALLEL TO BASE PLATE WHEN STOWED
- 4 APPLY LOCTITE #242 OR EQUAL TO ALL THREADS UNLESS OTHERWISE NOTED
- 5 APPLY A COAT OF SILICONE GREASE TO RCP MOTOR BORES PRIOR TO SHAFTS BEING INSTALLED
- 6 INSTALL GROUND WIRE ASSEMBLY TO BOARD AND RCP HOUSING

APPROX. WT:180.3 lbmass

THIRD ANGLE PROJECTION



**UNLESS OTHERWISE SPECIFIED  
DIMENSIONS ARE IN INCHES.**  
TOLERANCES ON DECIMALS ANGLES  
0 = ± 0.030 ± 1/2°  
.00 = ± 0.015  
000 = ± 0.010  
FRACTIONAL ± 1/64"  
1. ALL INSIDE EDGES TO HAVE  
.005" TO .035" FILLETS.  
2. ALL OUTSIDE EDGES TO HAVE  
.005" TO .015" CHAMFER OR RADIUS.  
125√ ON ALL MACHINED SURFACES

BOM			
ITEM	QTY	PART NUMBER	DESCRIPTION
1	1	4627603	BASE ASSEMBLY POWERLITE 10 FT CLR
2	1	4742501	RCP ASSEMBLY NSP STD
3	1	5034301	KIT, LIT WHL MAX LED 1080 (6) X 120VAC CLR
4	1	4706701	NSP LABEL KIT (NOT SHOWN)
5	1	4807801	KIT, SHIPPING NSP (NOT SHOWN)

**PROPRIETARY AND CONFIDENTIAL**  
THE INFORMATION CONTAINED IN THIS DRAWING IS THE SOLE PROPERTY OF THE WILL-BURT COMPANY ANY REPRODUCTION IN PART OR WHOLE WITHOUT THE WRITTEN PERMISSION OF THE WILL-BURT COMPANY IS PROHIBITED.



TITLE  
**NS 3.0 1080W 6x180 WHL  
120V SPT/FLD WHT**

APPROVALS	DATE	SIZE	DWG NO	REV
DRAWN RCC	9/15/2014	B	721030020	00
CHECKED		PN:	721030020	SHEET 2 OF 2