

REVISION HISTORY				
ECN	REV	DESCRIPTION	DATE	BY/APPR
10272	00	INITIAL RELEASE	8/30/2010	CJM/
10341	A	TP-4602001 was 4022310	12/8/2010	CJM/
10428	B	ADDED DIMENSIONS; ADDED TABULATED BOM	2/10/2011	SMB/

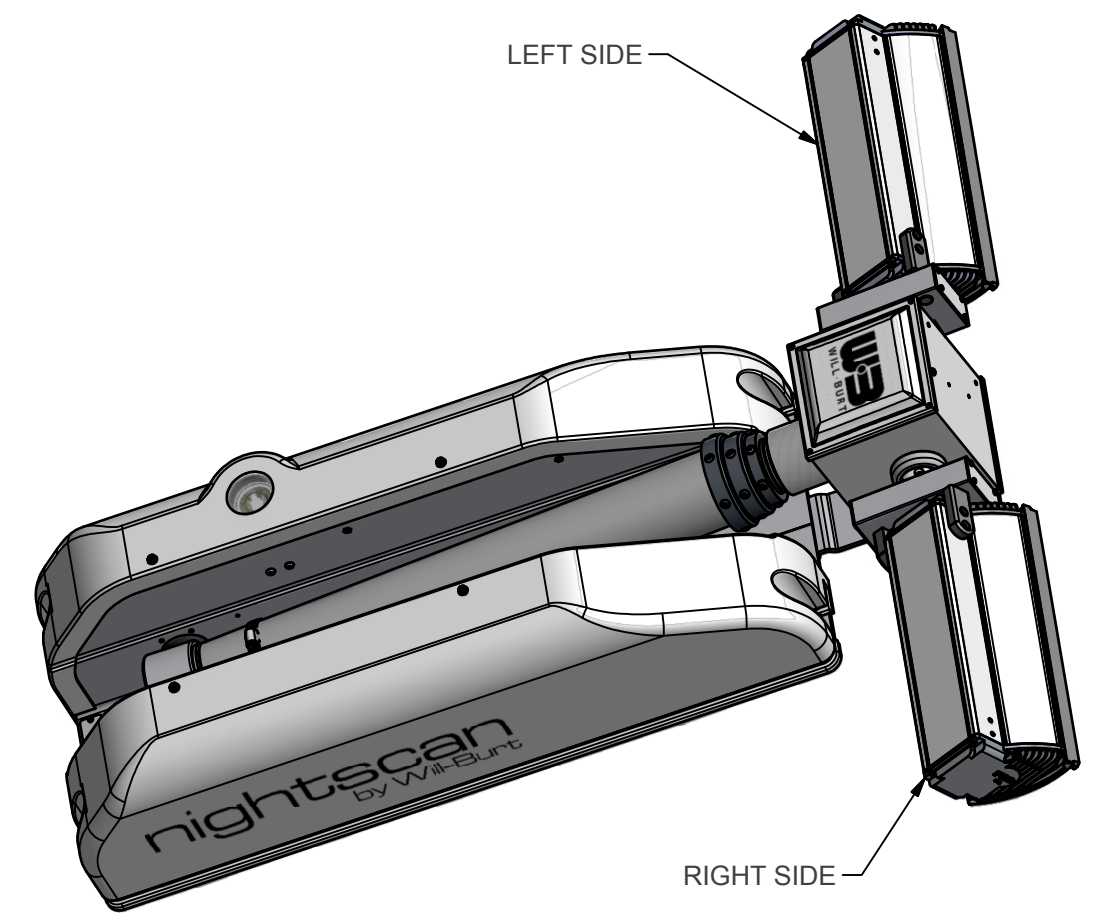

NOTES:

- 1 APPLY RTV #739 OR EQUAL TO ALL OPEN HOLES.
- 2 SEE WIRING DIAGRAM 46066 FOR ALL UNITS.
- 3 SET LIGHT BARS HOME POSITION PARALLEL TO BASE PLATE WHEN STOWED.

APPROX. WT: 90.55 lbmass
 THIRD ANGLE PROJECTION

UNLESS OTHERWISE SPECIFIED DIMENSIONS ARE IN INCHES.
 TOLERANCES ON DECIMALS ANGLES
 0 = ± 0.030 ± 1/2°
 00 = ± 0.010
 000 = ± 0.005
 FRACTIONAL ± 1/64"
 1. ALL INSIDE EDGES TO HAVE .005" TO .035" FILLETS.
 2. ALL OUTSIDE EDGES TO HAVE .005" TO .015" CHAMFER OR RADIUS.
 125° ON ALL MACHINED SURFACES

PROPRIETARY AND CONFIDENTIAL
 THE INFORMATION CONTAINED IN THIS DRAWING IS THE SOLE PROPERTY OF THE WILL-BURT COMPANY ANY REPRODUCTION IN PART OR WHOLE WITHOUT THE WRITTEN PERMISSION OF THE WILL-BURT COMPANY IS PROHIBITED.

APPROVALS	DATE
DRAWN SMB	2/10/2011
CHECKED	

WILL-BURT AN EMPLOYEE OWNED COMPANY ORRVILLE, OH	
TITLE NS 1.8 2-LIGHT LONG OPTIMUM KIT	
SIZE B	DWG NO 720648041
PN: SEE TABLE	REV B
SHEET 1 OF 2	

4

3

2

1

BOM

ITEM	QTY	PART NUMBER	DESCRIPTION
1	1	4548301	NSC RCP, LIGHTS ONLY
2	1	SEE TABLE	LIGHT KIT
3	1	4522003	NSC BASE ASSEMBLY 6.0 WHITE
4	1	4558901	NSC LABEL KIT (NOT SHOWN)
5	1	900600	MAST OIL (SHIP LOOSE)
6	1	TP-4602001	MANUAL, NS 1.8/2.3, CE, CD VERSION (NOT SHOWN)
7	1	4584001	FILLER, CORRUGATED NSC



ASSEMBLY NO	ITEM 2 PART NO	ITEM 2 DESCRIPTION
720648041	4573501	OPT 2 LIGHT, 3000W (2-1500W 220VAC) WHT
720667041	4573509	OPT 2 LIGHT, 2000W (2-1000W 220VAC) WHT
720670041	4573513	OPT 2 LIGHT, 1800W (2-900W 220VAC) WHT

UNLESS OTHERWISE SPECIFIED
DIMENSIONS ARE IN INCHES.

TOLERANCES ON DECIMALS ANGLES
 0 = ± 0.030 ± 1/2°
 .00 = ± 0.010
 .000 = ± 0.005

FRACTIONAL ± 1/64"

1. ALL INSIDE EDGES TO HAVE
.005" TO .035" FILLETS.
 2. ALL OUTSIDE EDGES TO HAVE
.005" TO .015" CHAMFER OR RADIUS.

125° ON ALL MACHINED SURFACES

APPROX. WT: 90.55 lbmass

THIRD ANGLE PROJECTION



PROPRIETARY AND CONFIDENTIAL
 THE INFORMATION CONTAINED IN THIS
 DRAWING IS THE SOLE PROPERTY OF THE
 WILL-BURT COMPANY ANY REPRODUCTION
 IN PART OR WHOLE WITHOUT THE WRITTEN
 PERMISSION OF THE WILL-BURT COMPANY IS
 PROHIBITED.

WB AN EMPLOYEE OWNED COMPANY
 WILL-BURT ORRVILLE, OH

TITLE
**NS 1.8 2-LIGHT LONG
 OPTIMUM KIT**

APPROVALS	DATE
DRAWN SMB	2/10/2011
CHECKED	

SIZE	DWG NO	REV
B	720648041	B
PN: SEE TABLE		SHEET 2 OF 2

4

3

2

1