

CUSTOMER INTERFACE DRAWING:  
ECN 13591 REV. A - RELEASE DATE: 4/21/2017

ITEM WEIGHTS:  
MAST 2.1-10M STILETTO AL - 360 LBS. (164 Kg)  
CONTROL BOX - 5.5 LBS. (2.5 Kg)  
SUPPORT BRACKET - 18 LBS. (8.2 Kg)  
3 METER CABLES (QUANTITY 2) - 10 LBS. (4.5 Kg)

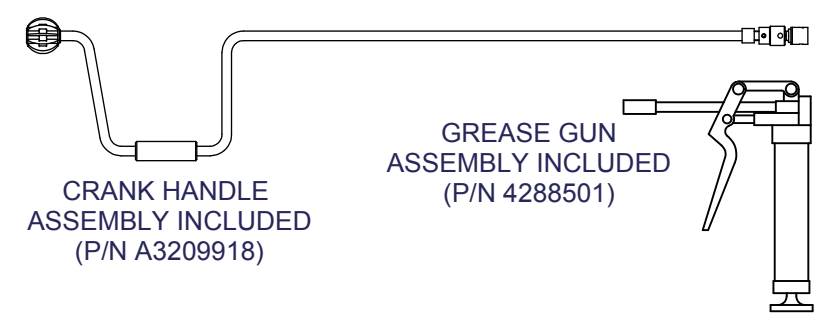

- NOTES:
- CONTACT FACTORY FOR ALTERNATIVES TO THE DEPICTED INTERFACE.
  - THE SCREW REQUIRES PERIODIC LUBRICATION WITH A SUPER PREMIUM AEROSPACE LUBRICANT. A THREE FLUID OUNCE CARTRIDGE P/N: 4288601 IS AVAILABLE.
  - MAST INCLUDES 3 METERS (10ft) LONG MOTOR TO CONTROL CABLE (P/N 5433101) AND 3M (10ft) LONG MAST-SENSOR TO CONTROL CABLE (P/N 5433201); NOT SHOWN.
  - THE CONTROL BOX (P/N 4453901, NOT SHOWN) MUST BE ORDERED SEPARATELY. LOOSE POWER CONNECTOR (P/N 213075) INCLUDED.
  - "-XXXX" IN THE PART NUMBER DENOTES MAST FINISH. FOR A LIST OF FINISH OPTIONS, SEE "FINISH SPECIFICATION TABLE" AT [WWW.WILLBURT.COM](http://WWW.WILLBURT.COM)

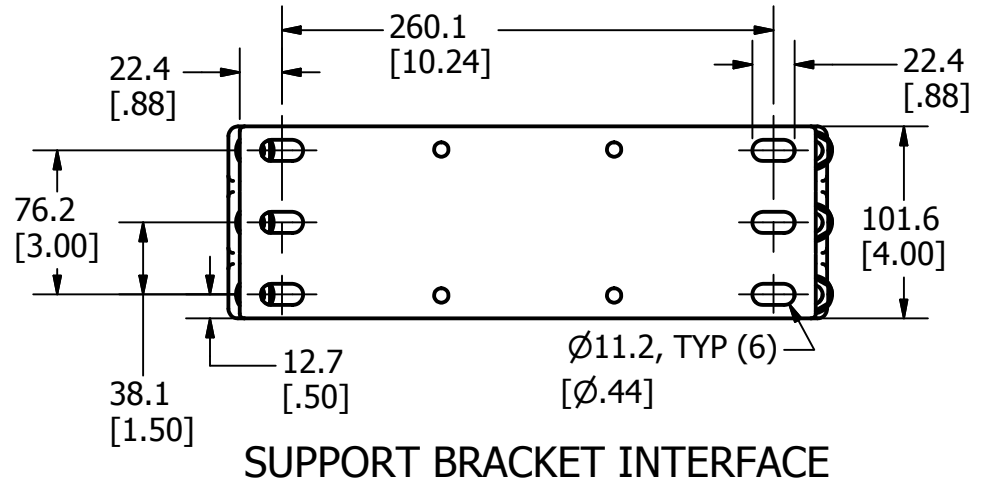
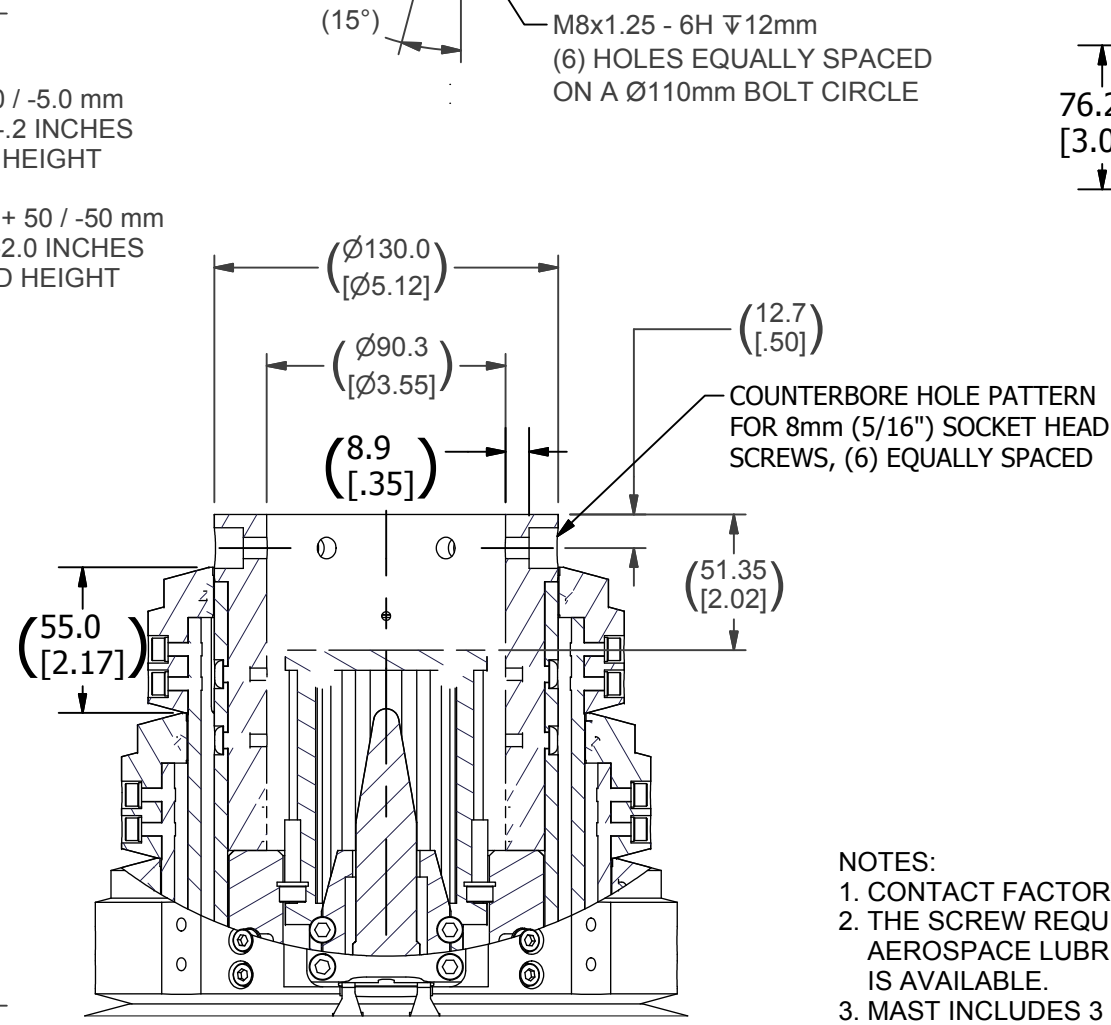
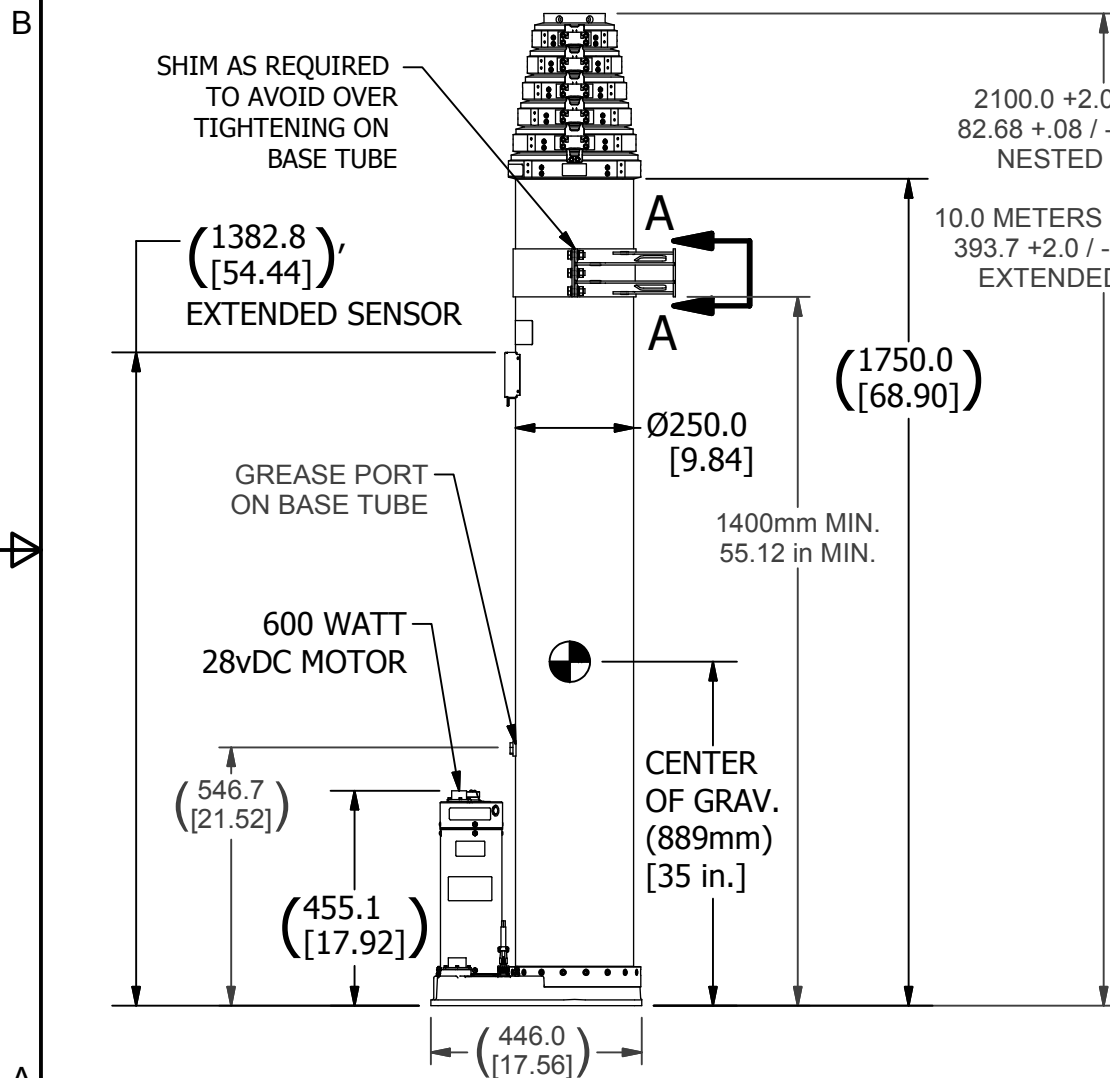
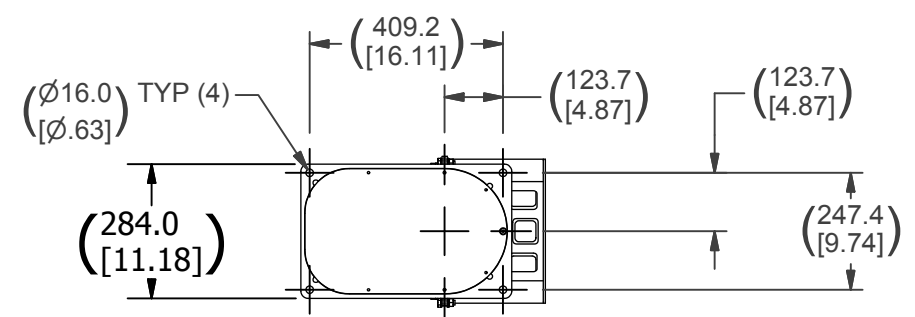

MATERIAL: <b>(ALUMINUM CONSTRUCTION)</b>	PROPRIETARY AND CONFIDENTIAL THE INFORMATION CONTAINED IN THIS DRAWING IS THE SOLE PROPERTY OF THE WILL-BURT COMPANY ANY REPRODUCTION IN PART OR WHOLE WITHOUT THE WRITTEN PERMISSION OF THE WILL-BURT COMPANY IS PROHIBITED.	<b>W3</b> AN EMPLOYEE OWNED COMPANY WILL-BURT ORRVILLE, OH	
FINISH: <b>SEE NOTE 5</b>	UNLESS OTHERWISE SPECIFIED DIMENSIONS ARE IN INCHES THIRD ANGLE PROJECTION	TITLE: <b>STILETTO AL 2.1-10M CUSTOMER DRAWING</b>	
DRAWING NOT TO SCALE		P/N: <b>711991010-XXXX</b>	DATE: <b>12/18/2016</b>
ALL DIMENSIONS AND PERFORMANCE PARAMETERS ARE PROVIDED FOR REFERENCE ONLY AND ARE SUBJECT TO CHANGE WITHOUT NOTICE.		APPROXIMATE WEIGHT: <b>N/A</b>	TUBE SET: <b>REV A</b>
			DRAWN BY: <b>DAJ</b>

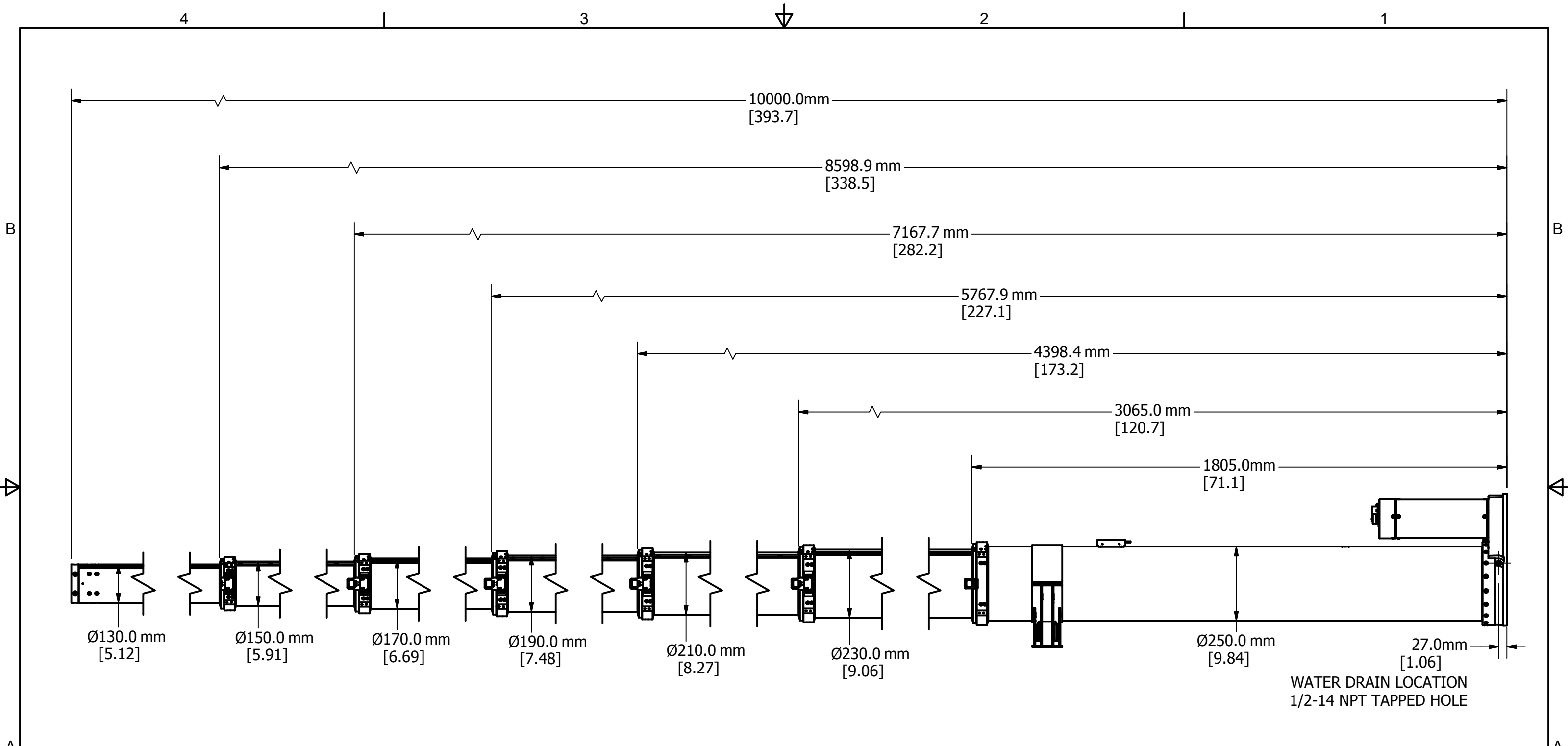

EXTENDED MAST, COLLAR HEIGHTS & TUBE DIAMETERS

MATERIAL:	<b>PROPRIETARY AND CONFIDENTIAL</b> THE INFORMATION CONTAINED IN THIS DRAWING IS THE SOLE PROPERTY OF THE WILL-BURT COMPANY ANY REPRODUCTION IN PART OR WHOLE WITHOUT THE WRITTEN PERMISSION OF THE WILL-BURT COMPANY IS PROHIBITED. UNLESS OTHERWISE SPECIFIED DIMENSIONS ARE IN INCHES THIRD ANGLE PROJECTION	<b>W3</b> AN EMPLOYEE OWNED COMPANY WILL-BURT ORRVILLE, OH	
FINISH:		TITLE: STILETTO AL 2.1-10M CUSTOMER DRAWING P11991010-extendable constraints	
DRAWING NOT TO SCALE	ALL DIMENSIONS AND PERFORMANCE PARAMETERS ARE PROVIDED FOR REFERENCE ONLY AND ARE SUBJECT TO CHANGE WITHOUT NOTICE.	DATE: 12/18/2016	DRAWN BY: DAJ
	APPROXIMATE WEIGHT: N/A	TUBE SET:	REV A