

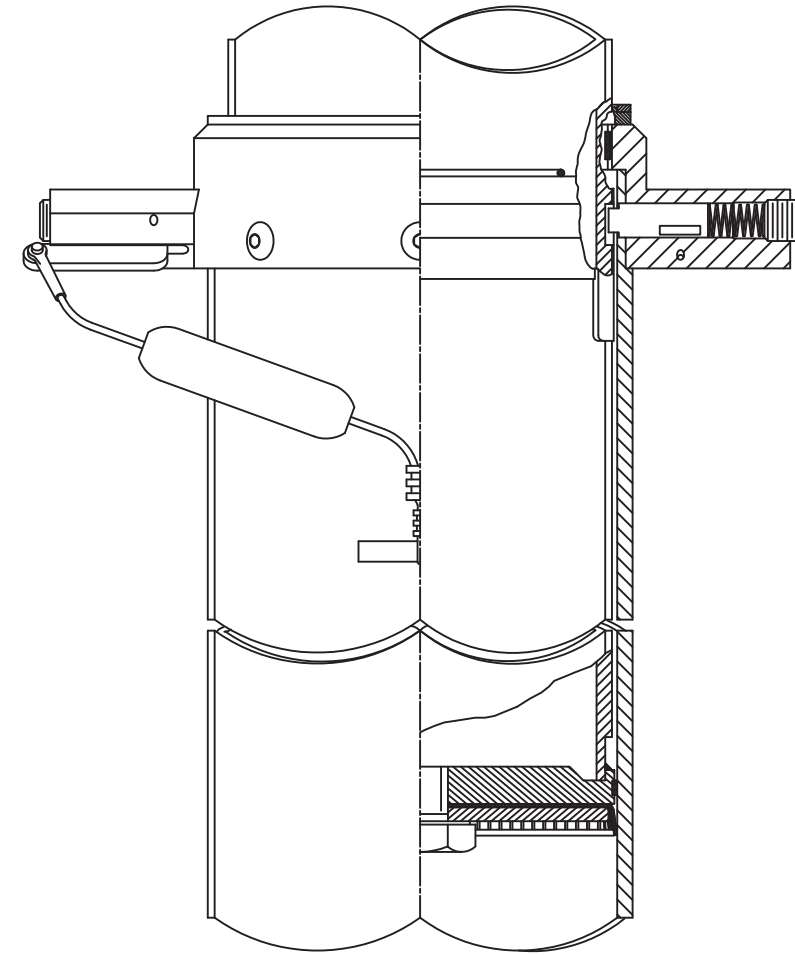

REVISION HISTORY				
ECN	REV	DESCRIPTION	DATE	BY/APPRV.
10187	00	INITIAL RELEASE	8-19-10	AW/
10228	A	REMOVE CRATE	9-14-10	AW/

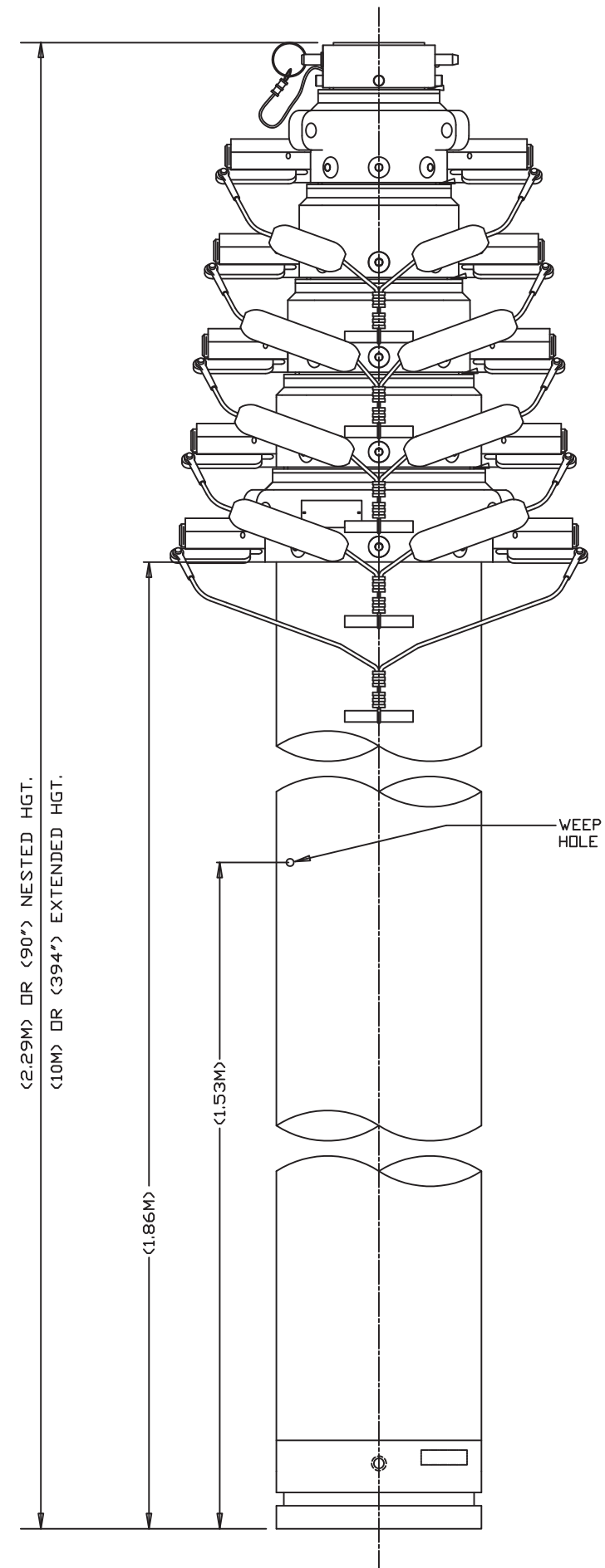

MATERIAL SEE PARTS LIST	UNLESS OTHERWISE SPECIFIED DIMENSIONS ARE IN INCHES. TOLERANCES DECIMALS ANGLES 0 = ±N/A ±N/A 00 = ±N/A ±N/A 000 = ±N/A ±N/A FRACTIONS ± N/A BREAK ALL SHARP CORNERS 125 / FINISH ON ALL MACHINED SURFACES	THIS DOCUMENT CONTAINS PROPRIETARY INFORMATION AND SHALL NOT BE USED OR REPRODUCED OR ITS CONTENTS DISCLOSED IN WHOLE OR IN PART, WITHOUT THE PRIOR WRITTEN CONSENT OF THE WILL-BURT COMPANY.		 AN EMPLOYEE OWNED COMPANY ORRVILLE, OHIO	
		FINISH REFERENCE: BLACK HARDCOAT PER MIL-A-8625, TYPE III, CLASS 2 WITH PTFE (TEFLON)	SIGNATURE DATE DRAWN BY: AW 8-19-10 CHECKED BY: APPROVED BY:	TITLE: PNEU MAST 2.3M-10M HDL	