

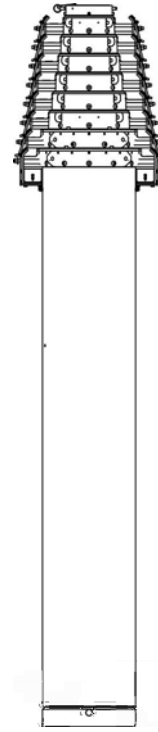

Pneumatic Mast with Remote Locking System Operating Instructions

(Heavy Duty, Super Heavy Duty, and Ultra Heavy Duty Models)

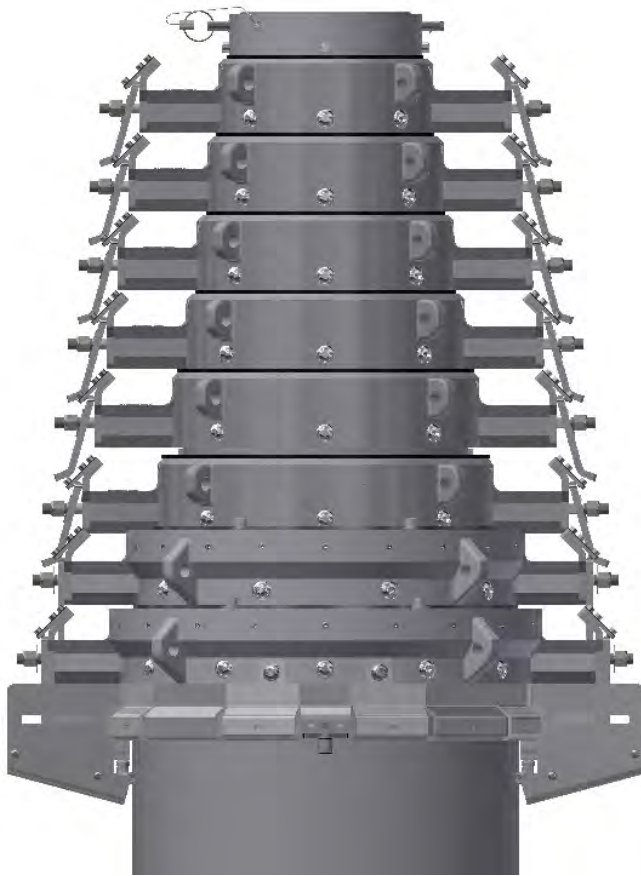

(2.7-15m UHD RLS P/N: 710991590 Shown)

The Will-Burt Company
401 Collins Blvd
Orrville, OH 44667, USA

Phone: +1 330 684 4000
E-Mail: info@willburt.com
Website: www.willburt.com

TP-5580101-B, November 2023
© 2023 The Will-Burt Company
Original Instructions



Authorized Representative:
Will-Burt Germany GmbH & Co. KG
Fischergasse 25
D-91344 Waischenfeld, Germany

Warranty

Will-Burt warrants its Pneumatic Mast with Remote Locking System to be free from defects in material and workmanship for a period of two (2) years, with such time period running from the date of shipment by Will-Burt. Will-Burt shall not be responsible for any damage resulting to or caused by its products by reason of failure to properly install, maintain or store the product; use of the product in a manner inconsistent with its design; unauthorized service, alteration of products, neglect, abuse, accident, or acts of God. This warranty does not extend to any component parts not manufactured by Will-Burt; provided, however, Will-Burt's warranty herein shall not limit any warranties by manufacturers of component parts which extend to the buyer.

THE FOREGOING WARRANTY IS IN LIEU OF ALL OTHER WARRANTIES, AND NO REPRESENTATIONS, GUARANTEES OR WARRANTIES, EXPRESS OR IMPLIED, INCLUDING BUT NOT LIMITED TO, A WARRANTY OF MERCHANTABILITY, FITNESS FOR A PARTICULAR PURPOSE, OR NONINFRINGEMENT ARE MADE BY WILL-BURT IN CONNECTION WITH THE MANUFACTURE OR SALE OF ITS PRODUCTS. NO EMPLOYEE, DISTRIBUTOR, OR REPRESENTATIVE IS AUTHORIZED TO CHANGE THIS WARRANTY IN ANY WAY OR GRANT ANY OTHER WARRANTY ON BEHALF OF WILL-BURT.

Claims for defects in material and workmanship shall be made in writing to Will-Burt within thirty (30) days of the discovery of defect. Failure to provide notice as required hereby shall be conclusive evidence that the product was in conformity with the warranty, and Will-Burt shall be released from any and all liability relating to the product. Will-Burt may either send a service representative or have the product returned to its factory at Buyer's expense for inspection. If judged by Will-Burt to be defective in material or workmanship, the product will be replaced or repaired at the option of Will-Burt, free from all charges except authorized transportation.

THE REMEDIES OF BUYER SET FORTH HEREIN ARE EXCLUSIVE AND ARE IN LIEU OF ALL OTHER REMEDIES. THE LIABILITY OF WILL-BURT WHETHER IN CONTRACT, TORT, UNDER ANY WARRANTY, OR OTHERWISE, SHALL NOT EXTEND BEYOND ITS OBLIGATION TO REPAIR OR REPLACE, AT ITS OPTION, ANY PRODUCT OR PART FOUND BY WILL-BURT TO BE DEFECTIVE IN MATERIAL OR WORKMANSHIP. WILL-BURT SHALL NOT BE LIABLE FOR COST OF INSTALLATION AND/OR REMOVAL, OR BE RESPONSIBLE FOR DIRECT, INDIRECT, SPECIAL OR CONSEQUENTIAL DAMAGES OF ANY NATURE.

Contents

1	Safety Summary	5
1.1	Signal Word Definitions.....	5
1.2	Safety Instructions	5
1.3	Symbols Used on Product Labels	13
2	Specification Compliance	15
2.1	CE Declaration of Conformity	15
3	Introduction	17
3.1	Intended Use.....	18
3.2	Definition of Terms and Abbreviations	18
3.3	Major Components.....	19
3.3.1	Telescoping Mast.....	20
3.3.1.1	Hardware Bag (P/N: 902853 or 5032501).....	22
3.3.1.2	Drain Kit (P/N: 902982)	24
3.3.1.3	Magnetic Warning Kit	25
3.3.1.4	Hold Down Leash.....	27
3.3.1.5	Mast Top Cover (P/N: 902989 or 5063501)	27
3.3.1.6	Identification Plate (P/N: 902851)	28
3.3.1.7	Label Kit (English)	28
3.3.2	Control System	28
3.3.3	Pneumatic System Options (Sold Separately).....	30
3.3.4	Mounting Hardware Options (Sold Separately)	31
3.3.4.1	Base Plate Options	31
3.3.4.2	Support Bracket Options	34
3.3.4.3	Shelf Bracket.....	39
3.3.5	Payload Platform and Stub Adaptor Options (Sold Separately)	39
3.3.6	Guy Line Options (Sold Separately)	41
3.3.7	Additional Accessory Options (Sold Separately)	42
4	Technical Data	43
4.1	Specifications for all Pneumatic Masts with Remote Locking Systems	43
4.2	Heavy Duty Locking Masts	44
4.3	Super Heavy Duty Locking Masts	46
4.4	Ultra Heavy Duty Locking Masts	48
4.5	Installation Specifications.....	50
4.5.1	Mast Installation Specifications	51
4.5.2	Non-Rotating Base Plate Installation Specifications	55
4.5.3	Rotating Base Plate Installation Specifications	57
4.5.4	Turning Handle Assembly Installation Specifications	58
4.5.5	Support Bracket Assembly Installation Specifications	59
4.5.6	Internal Mounting Kit Installation Specifications.....	63
4.5.7	Shelf Bracket Assembly Installation Specifications.....	66
4.5.8	Control Box Installation Specifications.....	68
5	Installation	69
5.1	Pre-Installation Check.....	69
5.2	Installation Equipment.....	70
5.3	Installation Hardware	71
5.4	Lift the Mast System	76
5.5	Unpack the Mast System	76

5.6 Mast Installation External Mount.....	78
5.6.1 External Mount Quick Summary	79
5.6.2 External Mount Detailed Instructions	80
5.6.2.1 Select a Suitable Mounting Location.....	80
5.6.2.2 Install the Shelf Bracket (Optional).....	81
5.6.2.3 Attach the Base Plate to the Mast.....	82
5.6.2.4 Position the Mast.....	83
5.6.2.5 Install the External Support Bracket.....	83
5.6.2.6 Secure the Base Plate to the Mounting Surface	90
5.6.2.7 Install the Turning Handles (Rotatable Mast Systems Only).....	91
5.7 Mast Installation: Internal Mount	92
5.7.1 Internal Mount: Quick Summary	93
5.7.2 Internal Mount Detailed Instructions	94
5.7.2.1 Select a Suitable Mounting Location.....	94
5.7.2.2 Begin Installation of the Internal Mounting Kit.....	95
5.7.2.3 Lower Mast through the Internal Mounting Kit	99
5.7.2.4 Attach the Base Plate to the Mast.....	99
5.7.2.5 Position the Mast.....	100
5.7.2.6 Secure the Base Plate to the Mounting Surface	100
5.7.2.7 Complete Installation of the Internal Mounting Kit.....	101
5.8 Install the Control and Pneumatic Systems	105
5.8.1 Control and Pneumatic Systems Installation Quick Summary.....	105
5.8.2 Control and Pneumatic Systems Installation Detailed Instructions.....	106
5.8.2.1 Install the Drain and Relief Fittings	106
5.8.2.2 Install the Air Supply	108
5.8.2.3 Install the Control Box	109
5.8.2.4 Connect the Air Supply to the Control Box.....	110
5.8.2.5 Connect the Control Box to the Mast	111
5.8.2.6 Exhaust the Control Box (Optional).....	112
5.8.2.7 Connect the HHRC to the Control Box (Optional Installation).....	113
5.8.2.8 Connect Customer Power to the Control Box	115
5.9 Install the Drain Kit.....	116
5.10 Install the Magnetic Warning Kit	118
5.11 Additional Accessory Installation	122
5.12 Test the Installation.....	122
5.13 Install Payload.....	123
6 Operation.....	125
6.1 Pre-Operation Check	125
6.2 Operation Equipment	126
6.3 Mast System Operation	126
6.3.1 Prepare the System	127
6.3.2 Extend the Mast.....	127
6.3.2.1 Partial Extension Applications.....	128
6.3.2.2 Mast Extension Procedures	130
6.3.3 Lower the Mast	133
6.4 Emergency Retraction Procedure.....	135
7 Transportation.....	137
7.1 General Transportation	137
7.2 Shipping.....	138

8 Maintenance and Adjustments	139
8.1 Pre-Maintenance Check	139
8.2 Maintenance Equipment	140
8.3 Replacement Parts	141
8.4 Periodic Maintenance	141
8.4.1 Mast Cleaning and Lubrication	142
8.4.2 Weatherizing	144
8.5 Corrective Maintenance	145
8.5.1 Special Procedure: Reed Switch Adjustment	145
8.5.2 Replace Collar Inserts	145
8.5.3 Replace External Bumpers	147
8.5.4 Replace External Wipers	148
8.5.5 Ultra Heavy Duty Bearing Strips	149
8.5.6 Ultra Heavy Duty Collar Adjustment	151
8.6 Collar Setup	153
8.6.1 Base Tube Collar Setup	153
8.6.2 Intermediate Tube Collar Setup	160
8.7 Long-Term Storage	168
8.8 System Disposal	168
9 Troubleshooting	169
10 References	171
10.1 Extended Glossary of Terms	171
10.1.1 General Terms and Abbreviations	171
10.1.2 Mounting Position Terms	173
10.2 Drawings	173
10.3 System Wiring Diagram	173
10.4 Mast Wind Load Capacity	175
10.4.1 Catalog Model 6-25 HDL	176
10.4.2 Catalog Model 7-30 HDL	177
10.4.3 Catalog Model 7-42 HDL	178
10.4.4 Catalog Model 10-60 HDL	179
10.4.5 Catalog Model 9-50 SHDL	180
10.4.6 Catalog Model 10.3-60 SHDL	181
10.4.7 Catalog Model 8-39 UHDL	182
10.4.8 Catalog Model 11.3-59 UHDL	183
10.4.9 Catalog Model 3-20M UHDL	184
10.4.10 Catalog Model 14.3-80 UHDL	185
11 Document History	187

1 Safety Summary

This section describes safety instructions for the Pneumatic Mast with Remote Locking System that personnel must understand and apply throughout all product activities such as transportation, handling, installation, operation, maintenance, storage, disposal and troubleshooting. Read and understand this entire document, and contact The Will-Burt Company with any questions, before performing any procedure outlined in this document. Keep this document during the entire duration of use of the device. Pass this document along to trained and qualified end users.

1.1 Signal Word Definitions

The following signal words and definitions are used to indicate hazardous situations:

DANGER

DANGER indicates an imminently hazardous situation that, if not avoided, will result in death or serious injury.

WARNING

WARNING indicates a potentially hazardous situation that, if not avoided, could result in death or serious injury.

CAUTION

CAUTION indicates a potentially hazardous situation that, if not avoided, may result in minor or moderate injury or equipment damage. It is also used to alert against unsafe practices.

1.2 Safety Instructions

DANGER

Electrocution Hazard! Contact with high voltage will result in death or serious injury. Observe general safety precautions for handling equipment using high voltage. Do not locate or operate mast near electrical lines, cables or other unwanted sources of electricity. Allow sufficient clearance on all sides of mast to allow for side sway. Do not operate mast during an electrical storm. Be certain electrical cables are undamaged and properly terminated. Do not touch live wires. Follow OSHA or other national safety regulations when working near energized power lines. Personnel working with or near high voltages should be familiar with methods of resuscitation.

DANGER

Disconnect Power for Service! Always disconnect all power sources following proper lock-out tag-out procedures before performing service, repair or test operations. Remove the tethered hand held control where applicable for added protection during maintenance.

⚠ DANGER

Mast Tip Over Hazard! Mast tip over could result in death or serious injury. Before operation, be certain mounting structure is capable of resisting forces generated from all loading and environmental conditions, including, but not limited to, mast size and weight, payload and cable size and weight, payload sail area, wind speed, guy line arrangement, support bracket or roof line location, and base plate assembly. Do not operate in wind speed conditions exceeding the maximum rated wind speed. Do not operate on slopes exceeding the maximum deployment angle. Do not install a payload that exceeds the maximum payload lifting capacity of mast. Do not install a payload with the center of gravity offset from mast centerline exceeding the maximum allowed offset. Stand clear of mast and mast payload during operation. Be certain mast is level and secure before and during installation, operation, and maintenance.

⚠ DANGER

Falling Objects from Mast Hazard! Wear a protective hard hat when working on mast or situated near mast operating area while mast is extending, retracting or deployed in any position above the nested position. Improperly secured payload or mast components, ice formations, etc. could be dislodged from mast and fall. Be sure the payload is properly installed and secured.

⚠ DANGER

Relocation/Driving Hazard! Do not relocate the system during operation or while mast is extended to any height above the nested position or powered up. Do not move vehicle until mast has been securely nested and isolated from power. Power-up and operate mast only if the vehicle is stationary and securely parked with the parking brake properly applied. Do not put mast in service or operate without the vehicle interlock warning circuit or magnetic warning kit installed to provide confirmation mast is nested prior to moving the vehicle. Contact The Will-Burt Company Engineering for special on-the-move situations for military only use on specialized products.

⚠ DANGER

Burst Hazard! For pneumatically operated masts, do not operate without the over-pressure safety valve installed. Keep personnel clear of safety valve exhaust direction. Do not exceed the maximum rated pressure of mast. If the mast air pressure is not fully discharged prior to removing air hoses, a rapid release of air pressure will occur requiring hearing and eye protection.

⚠ WARNING

Payload Lifting Hazard - Intended Use! The mast is intended to lift a specific payload for lighting, surveillance or communication use only. Any other use without written consent is prohibited and could cause death or serious injury. Do not use mast to lift personnel. Do not exceed specified payload capacity. Large payload wind sail areas can reduce payload capacity. Consult The Will-Burt Company engineering.

⚠ WARNING

Read Operating Instructions! Read and observe the operating instructions. Non-observance of the instructions, operation which is not in accordance with use as prescribed in the instructions, wrong installation or incorrect handling can seriously affect the safety of operators and machinery. Adhere to the safety instructions when carrying out any activity relating to the Pneumatic Mast with Remote Locking System.

⚠ WARNING

Trained Personnel Only! This product is intended for use by trained professionals only. It is not intended for general use by the public or untrained personnel. Handling, installation, operation and maintenance to be performed by trained and authorized personnel only. Only a properly trained and qualified certified electrician should perform electric installations and service.

⚠ WARNING

Erratic Mast Operation Impact Hazard! The mast should operate smoothly during extension and retraction. If erratic mast motion is observed during extension or retraction that results in impact loading between the tube and the tube collar (mechanical travel stop), cease use of the mast and contact The Will-Burt Company service department. Repeated operation with impact loading can damage tubes and lead to mast separation.

⚠ WARNING

Over-current Protection! Over-current protection or power switching by the installer on mast incoming power supply as specified in this document should be a type suitable to allow lock-out tag-out procedures for power disconnect.

⚠ WARNING

Safety Instruction - Explosion! For outdoor use only. Do not use in explosive areas or areas that have been classified as hazardous as defined in Article 500 of the National Electric Code or equivalent national standards. Do not use in the presence of flammable gases or liquids such as paint, gasoline or solvents. Do not use in areas of limited ventilation or where high ambient temperatures are present.

⚠ WARNING

Safety Equipment (PPE)! Proper personal protective equipment (PPE) like hard hats, gloves, and safety shoes shall be properly worn while working on mast or near the deployment area of mast. In addition, eye protection shall be worn during maintenance procedures. Follow national PPE guidelines in your area of operation.

⚠ WARNING

Pinch Point Hazard! Keep clear of all moving parts like mast collars nesting. Be sure to stay clear of system during operation. Moving parts can crush and cut resulting in serious injury. The mast shall be mounted out of reach of the operator during operation.

⚠ WARNING

Crush Hazard - Mast Failure! Do not stand directly beneath mast or its payload. Be certain the payload is properly installed and secured.

⚠ WARNING

Entanglement Hazard! Tangled cables can cause equipment damage. Ensure payload cables, Nycoil®, trip lines, guy lines or other cables are not tangled and are free to pay out as mast is deployed. Cables that get tangled or snagged on mast or other objects can cause mast tubes to lurch upward suddenly when the cable is freed. This can cause damage to mast and lead to mast separation if repeatedly allowed to continue.

⚠ WARNING

Health and Safety Hazard while Cleaning! Solvent used to clean parts is potentially dangerous. Avoid inhalation of fumes and prolonged contact to skin.

⚠ WARNING

Fire Hazard Solvent! Cleaning solvent, used for maintenance, is flammable and can be explosive. Do not smoke near solvent. Use cleaning solvent in a well-ventilated area. Keep cleaning solvent away from ignition sources. Always store cleaning solvent in the proper marked container and in a proper location.

⚠ WARNING

Bright Light Radiation Hazard! For systems equipped with scene lighting or look-up lights, do not look directly into lights when they are illuminated. Temporary impairment or permanent vision damage could occur.

⚠ WARNING

Personnel Freezing/Burn Hazard! If the system is equipped with lights, make sure the lights are completely cool before attempting to clean the lens, replace bulbs or perform maintenance. Wear gloves to protect from contact with exposed metal that may be at extremes of hot and cold temperatures from sun or cold outdoor exposure.

⚠ WARNING

Mast Extension Hazard - Obstruction! Extending mast into obstructions could result in death or serious injury and could render mast inoperable and partially extended. Before applying power and operating mast, be certain there is sufficient clearance above and to all sides of the expected location of the fully extended mast and payload. Keep all persons clear of mast and mast extension. Do not lean directly over mast. Locate the operator station such that the operator has a clear view of the operating space of mast and payload prior to deployment to avoid contact with overhead objects.

⚠ WARNING

Manual Retraction! For powered masts, make sure all power sources have been disconnected from the system prior to manually lowering mast to avoid unexpected start-up motion and/or damage to mast.

⚠ WARNING

Mast Lifting/Handling! Use extreme caution while lifting mast System and when mast System is suspended to avoid injury and equipment damage. Be certain mast is properly secured using at least two sling points at the center of gravity label. All operators should be aware of and follow the applicable local, regional, and national standards and codes of practice for slinging and transporting equipment. Never lift Mast System over people. Ensure lifting equipment including, but not limited to, lifting straps and hoist, are capable of handling the forces generated from lifting the system. Observe manufacturer instructions on lifting equipment.

⚠ WARNING

Remove Payload! For mast systems shipped with no payload (customer installed payloads), remove payload before performing maintenance on mast system. The Will-Burt Company installed devices can remain installed.

⚠ WARNING

Equipment Damage - Submerged! Do not submerge mast in liquid or operate the vehicle in a fording situation that would result in a submerged mast.

⚠ WARNING

Safety Instruction – Keep Clear! Keep personnel clear of the system during operation.

⚠ WARNING

Safety Instruction - Potential Air Contaminants! If internally mounted in a vehicle, air from mast and any accumulated water will discharge into the vehicle. Install appropriate drainage and venting.

⚠ WARNING

Fastener Vibration Hazard! Mast system and payload mounting hardware must include proper means to resist vibration loosening such as thread-locking compound, locking hardware, or equivalent. Use specified assembly torques appropriate for the fastener size.

⚠ CAUTION

Frozen Water Hazard! Water freezing inside mast or air fittings may render mast inoperable and cause major equipment damage such as tube deformation. Ensure water is free to exit at the base of mast. Open drain cock when mast is not in operation. The drain cock shall be installed at the lowest position in the pneumatic system. If mounted internally in a vehicle or structure, direct the draining water to a suitable location. Cover locking masts when not in use to limit water ingress. Non-locking masts stored outdoors should be covered if possible. A cover is available from The Will-Burt Company.

⚠ CAUTION

Safety Instruction - Guy Anchors! For masts using Guy Lines, verify the Guy Anchor point strength is adequate to support the Guy Line forces.

⚠ CAUTION

Lubrication! Do not lubricate the exterior of mast moving tubes. The lubricant will attract dust and other environmental contaminants into mast.

⚠ CAUTION

Equipment Damage - Forces! Before unloading the system, be certain the unloading region is capable of resisting forces generated from unloading the system including but not limited to system weight. Ensure the unloading region is level and has sufficient room and strength to hold the system. If the unloading region is incapable of meeting the requirements of the system, damage to the system and/or unloading region could occur.

⚠ CAUTION

Equipment Damage - Support Bracket! For masts using an upper support bracket, do not over-tighten mast support bracket. Over-tightening may damage the Base Tube causing mast tubes to stick.

⚠ CAUTION

Mast and Payload Access! The operator must provide safe means to access mast and payload during installation, removal and maintenance.

⚠ CAUTION

Tripping Hazard! Cables, trip lines, guy lines and guy anchors can be hard to see during and after installation. Any equipment posing trip hazards should be clearly marked.

⚠ WARNING

Lifting Hazard! Manually lifting over 55 lb. (25 kg) is prohibited. In the UK, all lifting equipment must be thoroughly examined annually by a competent person according to the Lifting Operations and Lift Equipment Regulations 1998. Equivalent regulations exist in other EU states.

⚠ WARNING

Safety Instruction – Roof Access! If the mast will be mounted to a vehicle, the operator must provide a safe means to access the roof of the vehicle during installation and maintenance.

⚠ WARNING

Pressurized Device Hazard! Mast disassembly prior to depressurization may release pressurized air jet. Completely lower the mast, depressurize and shut down power before disassembly. Ensure an over-pressurization safety valve is installed in the system.

⚠ WARNING

Safety Instruction – Remote Control! The equipment is subject to remote control and may be operated at any time. Persons working on the equipment should take appropriate precautions to ensure that any unexpected movement does not occur as this could lead to injury.

⚠ WARNING

Safety Instruction – Lightning! Lightning protection is not part of this system. A proper means of electrical grounding should be provided. Failure to observe this warning could result in death or serious injury.

⚠ WARNING

Crush Hazard – Hoist Failure! Use extreme caution while installing the base plate to the mast. Be certain mast is properly secured during installation of base plate. Death or serious injury could occur if hoist fails or mast slips suddenly.

⚠ WARNING

Safety Instruction – Operation! At all times prior to mast operation, ensure:

- The mast area is free of personnel and mechanical obstruction
- Be certain mast is level, stable, and secure before and during installation, operation, maintenance, and transportation. Operate on level ground only.
- Any transit tie-downs on the payload have been removed
- Before operating, the base section shall be within:
 - 5° of vertical for Heavy Duty masts with extended heights ≤ 60 feet
 - 3° for all Super Heavy Duty masts
- Ultra Heavy Duty masts: Before operating, the base tube for masts extended up to 60 feet (18.2 m) shall be within:
 - 5° of vertical for payloads 200 lb. (90.7 kg) or less
 - 4° of vertical for payloads 200 lb. to 800 lb. (90.7 kg to 362.9 kg)
 - 2° of vertical for payloads 800 lb. to 1,200 lb. (362.9 kg to 544.3 kg)
- Ultra Heavy Duty masts: Before operating, the base tube for masts extended 60 ft. to 80 ft. (18.2 m to 24.4 m) shall be within:

- 4° of vertical for payloads 600 lb. (272.2 kg) or less
- 1° of verticals for payloads 600 lb. to 1,200 lb. (272.2 kg to 544.3 kg)

All values assume a maximum of 12 inch (30.5 cm) payload offset. If offsetting any payload greater than 600 lb. (272 kg), the payload offset direction must be in-line with the tube keys, and not perpendicular to the keys.

⚠ WARNING

Burst Hazard! Over-pressurizing mast will trip safety valve and could result in death or serious injury. Do not exceed maximum operating pressure of 35 psi (241 kPa) for Heavy Duty, Super Heavy Duty, and Ultra Heavy Duty masts. Keep personnel clear of safety valve exhaust direction.

⚠ CAUTION

Safety Instruction – Mast Access! The operator must provide safe means to access the top of the mast during installation and removal of the payload.

⚠ CAUTION

Safety Instruction – Hose Installation! At all times while using pipe and hose during installation, recognize that:

- Pipe and hose should be routed, mounted and restrained to protect from damage
- Do not use second hand piping for installation. Use piping adhering to regional standards.
- Do not bend air pipe and hose at a radius less than specified by the manufacturer
- Pipes should be marked to avoid hazards from incorrect connection
- The exhaust should be fitted with a silencer and be directed away from personnel
- When routing piping, install in such a way as to minimize torsion on the joints
- Mounting of air pipe and hose shall be done with tools and in such a way to prevent air pipe and hose from easily disconnecting from the mast

⚠ CAUTION

Safety Instruction – Air Control Valve! Improper positioning and operation of air control valve can result in moderate injury or equipment damage. Air control valve must be mounted in a location where the operator has full view of the mast and mast operating space but does not make contact with the mast during operation (except for yokes). Only use a Hold-To-Run type air control valve or switch. The air control valve shall be normally open to atmosphere when the mast is in transit or not in use.

⚠ CAUTION

Drain Valve Kit Installation! Failure to follow Drain Kit installation instructions could damage the mast and render the mast inoperable. Read and understand the installation instructions before installing the Drain Kit.

⚠ CAUTION

Equipment Damage – Band Clamp Fasteners! Do not overtighten the band clamp fasteners. Overtightening may damage the base tube causing the mast tubes to stick.

⚠ CAUTION

Equipment Damage – Deviation! Deviation from standard operating conditions and procedures could cause system failure.

⚠ CAUTION

Safety Instruction - Motion on Power Interruption or Emergency Stop! When using a normally open control valve as required for vehicle applications, if power is lost or turned off or the emergency stop is activated while the mast is extended, the mast will begin releasing air pressure and retracting at a controlled rate until power is restored or the mast fully retracts.

⚠ CAUTION

Safety Instruction – Insufficient Mast Lock! Ensure all mast sections are locked prior to removing air from the mast. One unlocked section will result in all mast sections above it retracting back into the nested position.

⚠ CAUTION

Safety Instruction – Lock Adjustment! Do not adjust the lock hardware. Doing so can cause the mast lock to fail, resulting in mast retraction. Adjusting the lock hardware removes the warranty.

⚠ CAUTION

Safety Instruction – Hold Down Leash! To partially deploy the mast, use the hold down leash to tether the tubes to the mast payload platform. Do not use the hold down leash cable to secure mast sections to the base tube during operation. This causes the mast to fully retract after air is removed.

⚠ CAUTION

Safety Instruction - Guy Lines! For masts using guy lines, do not overtighten guy lines or tension them unevenly.

The following list contains reasonably foreseeable misuses of the mast system according to EN ISO 12100 5.3.2. These uses shall be avoided:

- Operating the mast with an obstruction in the functional space that prevents full extension or retraction
- Operating the mast near overhead power lines
- Operating the mast without the mast and operating space visible to the operator
- Driving the vehicle with the mast in a deployed position (any height above the nested position) or powered-up
- Operating the mast or leaving deployed in wind speeds higher than the specified maximum velocity
- Operating the mast on a non-level surface greater than the specified maximum angle
- Installing a payload greater than the maximum rated payload (weight and sail area) of the mast

1.3 Symbols Used on Product Labels

The following symbols are displayed on the product. The symbol meanings are as follows:



This symbol indicates an electrocution hazard or hazardous voltage hazard. There is voltage present inside mast and control box. Do not operate mast near electrical lines or during electrical storms. Contact with high voltage will result in death or serious injury.



This symbol indicates a pinch point hazard. Keep fingers and hands clear of moving parts.



This symbol indicates a tip-over hazard. The mast must be properly supported during transport, handling, installation, maintenance, operation and decommissioning. System tip-over could result in death or serious injury.



This symbol indicates a general warning. In this unit, this symbol indicates a frozen water hazard. Water must be permitted to exit mast to avoid ice damage to mast.



This symbol indicates a burst hazard. The mast contains air pressure. Never install the mast without installing the overpressure safety valve. Never operate the mast above the maximum rated pressure.



This symbol is used to remind users to read and understand the operator's manual before operating the mast system. Failure to follow operating instructions could result in death or serious injury. Read and understand operating instructions before handling, installing, operating, or maintaining the mast system.



This symbol indicates an electrical ground connection point.



This symbol is used to indicate the center of gravity (COG) of a fully nested mast in a horizontal transport position.

This page intentionally left blank.

2 Specification Compliance

2.1 CE Declaration of Conformity

Refer to the Product page at www.willburt.com for the latest Declaration of Conformity.

The Pneumatic Mast with Remote Locking System conforms to CE standards when used with a CE approved control system.

This page intentionally left blank.

3 Introduction

Thank you for selecting The Will-Burt Company for your critical payload elevation needs. These operating instructions describe the installation, operation, transportation, maintenance, storage, and troubleshooting procedures for the Pneumatic Mast with Remote Locking System (Heavy Duty, Super Heavy Duty, and Ultra Heavy Duty models). These procedures assume the use of standard catalog mast systems with a clear anodized finish. Procedures and characteristics for mast systems customized to meet customer-specific needs may vary. Review this document in its entirety. Contact The Will-Burt Company with any questions before performing any procedure outlined in this manual.

The views depicted in this manual are provided for clarification and are subject to change without notice. Views are not to scale.

The Pneumatic Mast with Remote Locking System comprises of:

- Telescoping mast
- Control System
- Pneumatic System (Sold Separately)
- Mounting Hardware (Sold Separately)
- Additional Accessory Options (Sold Separately)

The Pneumatic Mast with Remote Locking System is available in the following models:

- Heavy Duty Locking Pneumatic Masts
- Super Heavy Duty Locking Pneumatic Masts
- Ultra Heavy Duty Locking Pneumatic Masts

This manual is not for:

- Non-Locking Pneumatic Masts
- Standard Duty Pneumatic Masts
- Pneumatic Masts without the Remote Locking System

Note: Model numbers listed are for catalog masts only. Masts with other heights, capacities, and finishes are available. For more information on additional mast sizes, capabilities, and finishes, see www.willburt.com.

3.1 Intended Use

The Pneumatic Mast with Remote Locking System is intended for use by professionals in the fire/rescue/first responder/security/towing/cellular industries to provide elevated and directional emergency scene lighting and surveillance or communication capabilities. It is not intended for use by non-professionals. Do not use the mast to lift personnel. The Pneumatic Mast with Remote Locking System is intended to be installed on fire/rescue/towing first responder vehicles with the magnetic warning kit installed and operational.

The Pneumatic Mast with Remote Locking System is intended to be used only when the vehicle is stationary and the vehicle parking brake is properly applied. Do not supply input supply voltage or operate the mast system when the vehicle is in motion. The mast shall remain in the powered-down, nested position during vehicle motion. Contact The Will-Burt Company with any questions on the intended use or available training programs for installation and operation.

3.2 Definition of Terms and Abbreviations

Throughout this manual, the following terms are used.

General Terms:

- **HD** stands for Heavy Duty
- **Mast** refers to the telescoping Pneumatic Mast
- **Mast System** refers to the entire Pneumatic Mast system (telescoping mast, control system, pneumatic system, mounting hardware, and additional accessories)
- **Payload** refers to the object or equipment being raised by the mast to an operational height
- **RLS** stands for Remote Locking System
- **SHD** stands for Super Heavy Duty
- **UHD** stands for Ultra Heavy Duty

See Section 10.1 for an Extended Glossary of Terms used within this manual. The Extended Glossary of Terms includes:

- General Terms and Abbreviations (Section 10.1.1)
- Mounting Position terms (Section 10.1.2)

3.3 Major Components

This section describes major components of a mast system assuming the use of standard catalog masts systems with the Remote Locking System. Characteristics of components customized to meet customer-specific needs may vary. If necessary, contact The Will-Burt Company for additional details.

Major components of the mast system include:

- Telescoping Mast
 - Hardware Bag (P/N: 902853 or 5032501)
 - Drain Kit (P/N: 902982)
 - Magnetic Warning Kit
 - Hold Down Leash
 - Mast Top Cover (P/N: 902989 or 5063501)
 - Identification Plate (P/N: 902851)
 - Label Kit (English)
- Control System
- Pneumatic System Options (Sold Separately)
- Mounting Hardware Options (Sold Separately)
 - Base Plate Options
 - Non-Rotatable Base Plates
 - Rotatable Hardware Kits
 - Support Bracket Options
 - Internal (Roof) Mounting Kit
 - External Support Bracket
 - Shelf Bracket
- Payload Platforms and Stub Adaptors (Sold Separately)
- Guy Line Options (Sold Separately)
- Additional Accessory Options (Sold Separately)

3.3.1 Telescoping Mast

The telescoping mast (Figure 3-1):

- Is the structure used to raise the payload to an operational height.
- Consists of concentric, nesting mast tubes.
- Extends and retracts pneumatically.
- Can be non-rotating or rotating.
- Has locking collars. When desired tubes are raised and locked into position, the mast is depressurized.
- Has collars fitted to the top end of each tube except the top tube which is fitted with a top tube stop.
- Has two rectangular keys along each tube, except the base tube. These keys align with keyways in the next larger adjacent tube's collar and are used to establish azimuth (rotational) integrity between the tubes.
- Uses heat-treated super pins with a close azimuth design which are three times as strong as universal pins.

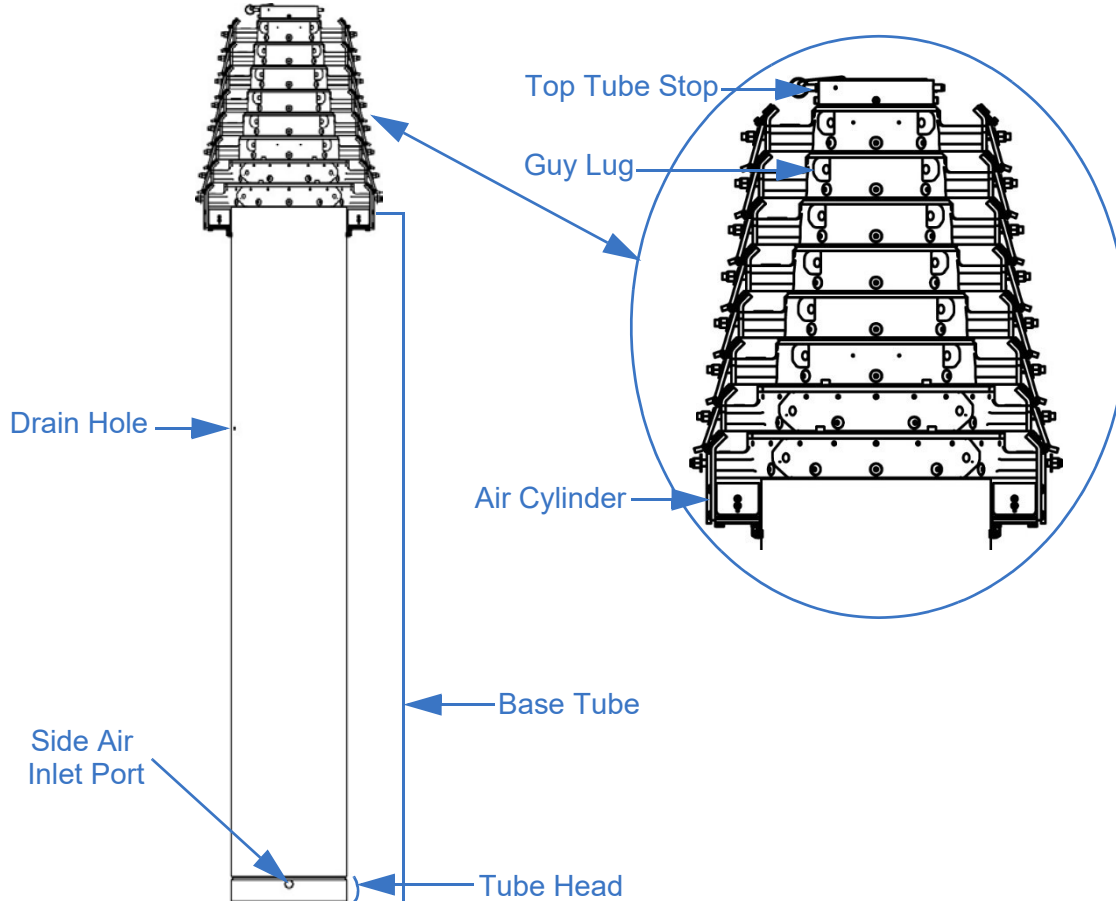

Figure 3-1 Ultra Heavy Duty Pneumatic Mast with Remote Locking System (P/N: 710991590 Shown)

The locking collar(s) (Figure 3-3):

- Guide bearings to reduce friction when contact is made between the guide plate and the latch lever from the above intermediate tube
- Uses heat-treated super pins and a close azimuth design
- On the base tube:
 - Locks and unlocks pneumatically
 - Has two air cylinders which are used to actuate the locks. A reed switch in each air cylinder (two total) communicates with the control to illuminate an LED when the mast is pressurized (30 psi) and when the locks are unlocked
- Above the base tube
 - Unlock mechanically when contact is made between the latch lever and the guide plate from the lock below
 - Use a spring to lock mechanically when the latch lever loses contact with the guide plate from the lock below

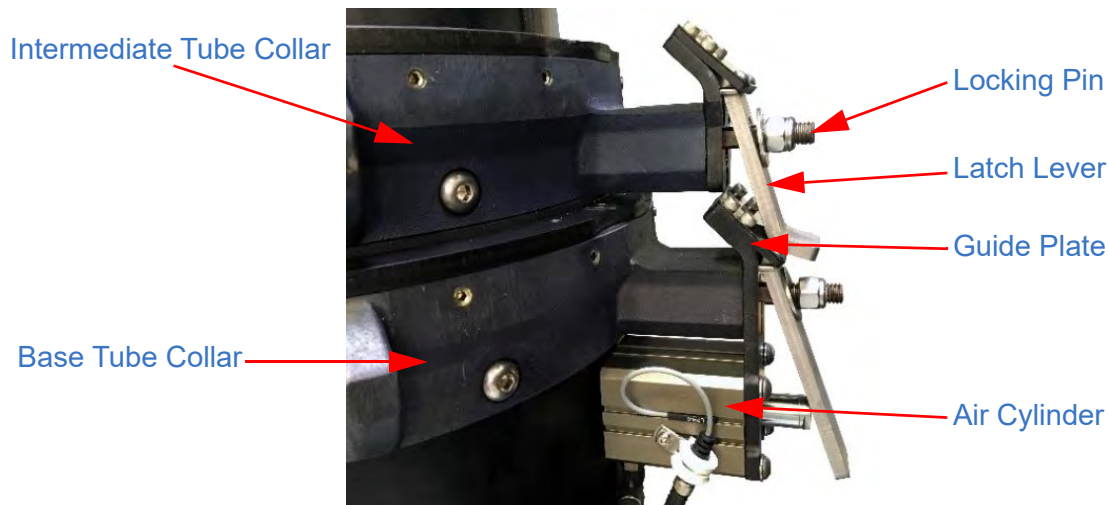
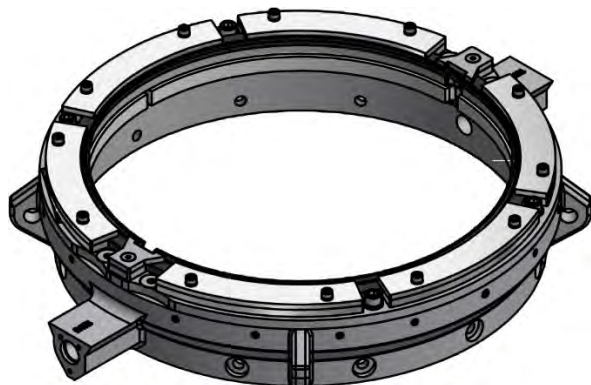
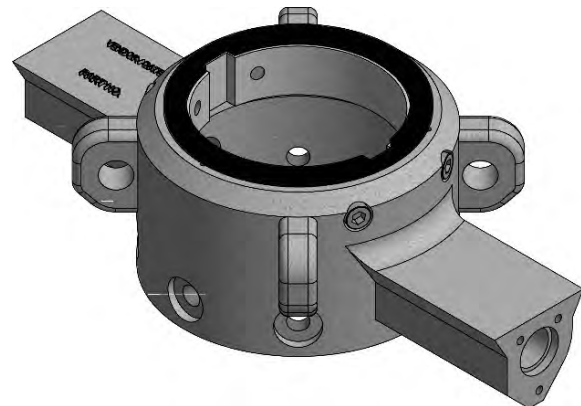

Figure 3-2 Locking Collar Components (Hose Guard Not Shown)

The top tube has a top tube stop which prevents the top tube from sliding too far down into a nested mast.



Locking Collar 13.5 and 12.375 Mast Sections



Locking Collars for 11.25, 10.00,
9.14, and 8.25 Mast Sections

Figure 3-3 Ultra Heavy Duty Locking Collars (Not to Scale)

Components shipping with the mast include:

- Hardware Bag (P/N: 902853 or 5032501)
- Drain Kit (P/N: 902982)
- Magnetic Warning Kit
- Hold Down Leash
- Mast Top Cover (P/N: 5063501 or 902989)
- Identification Plate (P/N: 902851) (Ships installed on mast)
- Label Kit (English) (Labels ship installed on the mast and with the manual)

3.3.1.1 Hardware Bag (P/N: 902853 or 5032501)

The mast system includes a hardware bag. Depending on the specific installation application, all hardware may not be used.

Heavy Duty and Super Heavy Duty masts ship standard with hardware bag P/N: 902853.

Ultra Heavy Duty masts ship standard with hardware bag P/N: 5032501.

The contents of the hardware bag (Figure 3-4) are used to:

- Secure the base plate to the mast:
 - (4) Screw $\frac{3}{8}$ -16 x 1 Flathead Stainless Steel (P/N: 2772)
 - (Ultra Heavy Duty): (4) Screw $\frac{1}{2}$ -13x1.25 flathead stainless steel (P/N: 5402)
- Secure the base plate to a mounting surface:
 - (4) Bolt $\frac{3}{8}$ -16 x 1- $\frac{1}{2}$ Inch, Stainless Steel (P/N: 901594)
 - (4) Flat Washer, $\frac{3}{8}$ Inch, Stainless Steel (P/N: 2054)
 - (4) Lock Washer, $\frac{3}{8}$ Inch, Stainless Steel (P/N: 0801)
 - (4) Nut $\frac{3}{8}$ -16 Inch, Hex, Heavy-Duty, Stainless Steel (P/N: 901593)

Note: Ultra Heavy Duty masts ship with (6) of each of the hardware the listed above (secure the base plate to a mounting surface).

- Protect the mast from over-pressurization:
 - (1) Safety Valve $\frac{1}{4}$ inch NPT, 35 PSI (P/N: 913961) (used on Ultra Heavy Duty models)
 - (1) Safety valve $\frac{1}{4}$ inch NPT, 55 PSI (P/N: 913962)

Note: Do not operate mast without safety valve properly installed

- Drain water and connect to the air supply line:
 - (2) Close Nipple ¼ Inch Brass (P/N: 900508)
 - (1) Brass Cross (P/N: 900516)
 - (1) Drain Cock #64-T (P/N: 900382)
 - For Hardware Bag 902853:
 - (1) ⅜ x ¼ Inch Reducing Bushing, 125 lb. Red Brass, NPT (P/N: 900522) (Used for Heavy Duty Masts)
 - (1) Threaded Hex Bushing ¼-½ Inch NPT Brass (P/N: 912293) (Used for Super Heavy Duty Masts)
 - For Hardware Bag 5032501:
 - (1) ⅜ x ¼ inch reducing bushing, 125 lb. red brass, NPT (P/N: 900522)
 - (1) Threaded hex bushing ½ x ⅜ inch NPT brass (P/N: 4097601)

These components ship in the parts bag (P/N: 17337) (not shown).

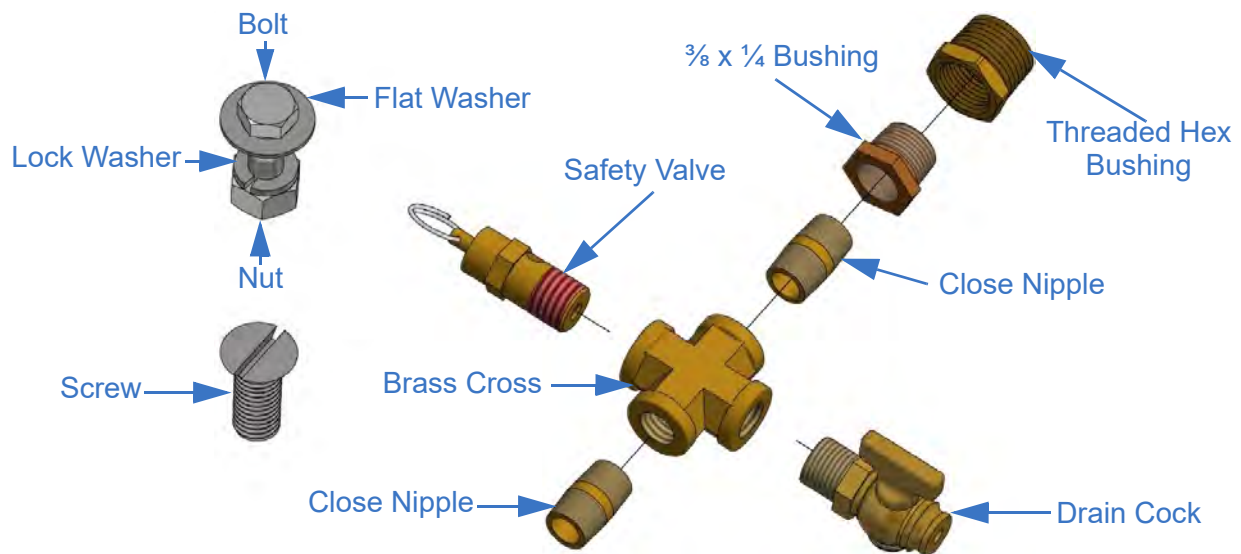

Figure 3-4 Contents of Hardware Bag

3.3.1.2 Drain Kit (P/N: 902982)

The drain kit provides a means to route draining water away from the mast by attaching one end of the drain kit to the drain hole and the other end outside the mounting structure area. Water that has accumulated in the mast should be periodically drained, particularly after the mast has been exposed to rain, in order to prevent damage.

The drain kit (Figure 3-5) includes:

- (1) Washer $\frac{3}{8}$ Inch, ID x $\frac{3}{4}$, OD x $\frac{1}{16}$ Thick (P/N: 900555)
- (1) Lock Nut $\frac{1}{8}$ Inch Brass (P/N: 900556)
- (1) $\frac{1}{4}$ Inch Hose Adaptor (P/N: 900564)
- (1) $\frac{1}{4}$ Inch Bulkhead Fitting (P/N: 900565)
- 8 Feet (2.4 m), $\frac{1}{4}$ Inch (6.35 mm) ID, Clear Polyethylene Tube (P/N: 900566)
- (1) Service Sheet 414 (P/N: 4306601) (Not shown)
- (1) Polyethylene Bag 11 x 18, 2 MILS (P/N: 4306301) (Not shown)

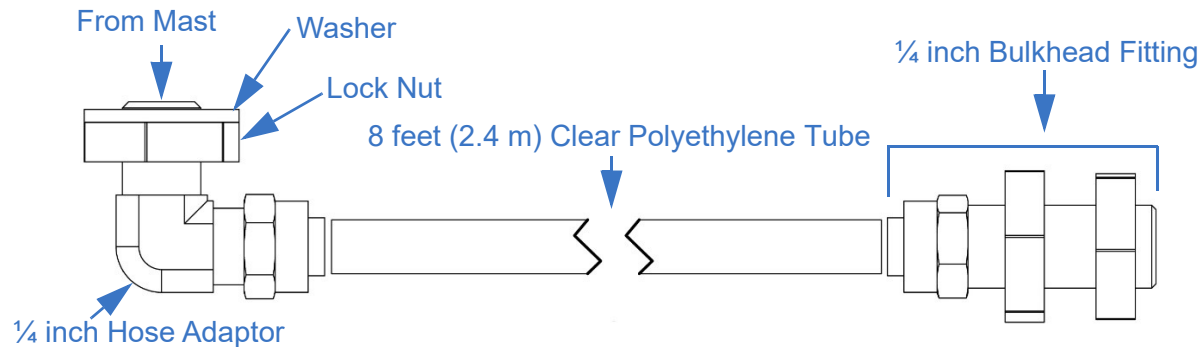

Figure 3-5 Drain Kit (P/N: 902982)

3.3.1.3 Magnetic Warning Kit

The magnetic warning kit is a system designed to warn against moving a vehicle while the mast is partially or fully extended. The operator should always visually confirm that the mast is entirely retracted before moving the vehicle.

The magnetic warning kit is packaged in a brown cardboard box, and in general includes the:

- Clamp which is a thin strip of coiled metal used to brace the switch assembly against the base tube
- Magnet which is cylindrical and covered with a wax-like coating
- Switch assembly which is attached to a small, rectangular casing
- Labels which are gray
- Flasher which has a cylindrical metal casing and is packaged in a rectangular box
- Two red plastic lights

Table 3-1 lists the magnetic warning kits for each mast model:

Table 3-1 Magnetic Warning Kits

Magnetic Warning Kit	Mast Model(s)	Figure/Table
P/N: 904314	7-42, 9-50, 10-60, 10.3-60, and 10.8-76	Table 3-2
P/N: 903525	7-30	Table 3-3
P/N: 5450001	7 ½ Top Tubes	Figure 3-6
P/N: 5450002	6 ¾ Top Tubes	Figure 3-6
P/N: 5450003	5 ¼ Top Tubes	Figure 3-6
Note: Mast Models 14.5-80, 15.7-100, 17-100, and 20-134 ship standard without a magnetic warning kit.		

Table 3-2 Magnetic Warning Kit

#	Description	Quantity	
1	Clamp	1	
2	Magnet Assembly	1	
3	Switch Label	1	
4	Notice Label	1	
5	Warning Label	1	
6	Flasher	1	
7	Light	2	
8	Relay	1	
9	Carton (Not Shown)	1	

Table 3-3 Magnetic Warning Kit

#	Description	Quantity	
1	Notice Label	1	
2	Magnet Assembly	1	
3	Switch	1	
4	Switch Bracket	1	
5	Flasher	1	
6	Light	2	
7	Clamp	1	
8	Nut	2	
9	Lock Washer	2	
10	Warning Label	1	
11	Carton (Not Shown)	1	

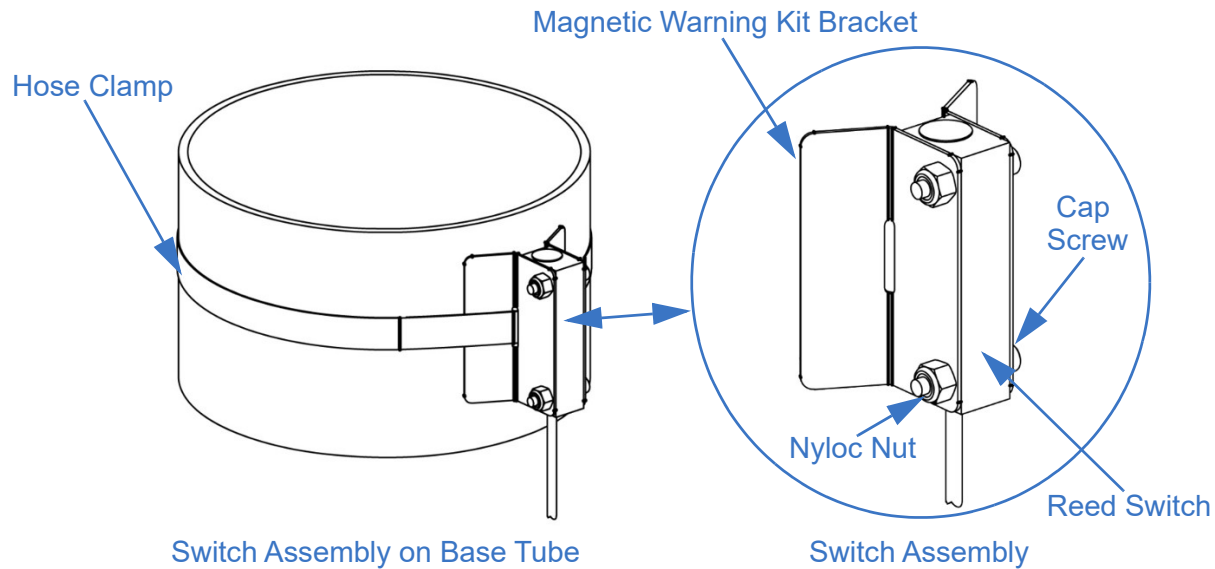

Figure 3-6 Magnetic Warning Kit

3.3.1.4 Hold Down Leash

The hold down leash is a wire cable that can be used to hold collars together for horizontal transportation, or used with a hold down platform to allow for partial extension of the mast.

3.3.1.5 Mast Top Cover (P/N: 902989 or 5063501)

The mast top cover (Figure 3-7) comes standard with locking masts.

The mast top cover is:

- A large bag with draw strings
- Pulled over the collars of a fully retracted mast to help protect the locking mechanism and interior of the mast from water, dust, debris, and other foreign material when the mast is not in use



Figure 3-7 Mast Top Cover (5063501 Shown)

3.3.1.6 Identification Plate (P/N: 902851)

Information pertaining to the mast can be found on the identification plate secured to the third collar up or the base tube collar (Figure 3-8).

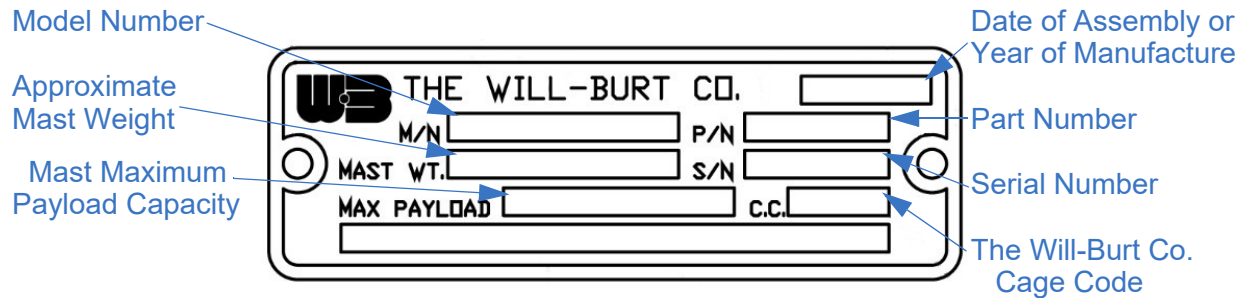

Figure 3-8 Identification Plate (P/N: 902851)

3.3.1.7 Label Kit (English)

The label kit is used to identify potential hazards within the mast system. Some of the labels come installed on the mast system. Additional labels are provided with the operator's manual (this document). These labels should be applied where the operator will have a clear view of them while operating the mast.

Contact The Will-Burt Company for information pertaining to alternate language label kits.

3.3.2 Control System

The Remote Locking System uses a control system to operate the mast. The available control systems are:

- 9-40 VDC
 - 5572601 – RLS Mast Control System With Handheld
 - 5572602 – RLS Mast Control System
- 24 VDC (Conforms to CE standards)
 - 5572603 – RLS Mast Control System With Handheld CE
 - 5572604 – RLS Mast Control System CE

The control system includes:

- Control Box (P/N: 5557301)
- Hand-Held Remote Controller (HHRC) (P/N: 5567001) (Not included in P/N: 5572602 or 5572604)
- 30 ft. Power Cable Assembly (P/N: 5567501)
- 30 ft. Sensor Cable (P/N: 5567601)
- 30 ft. 0.375 OD x 0.245 ID Air Hose (P/N: 108768)
- 30 ft. 0.250 OD x 0.125 ID Air Hose (P/N: 5558001)

The control box (Figure 3-9):

- Allows the operator to control the Pneumatic Mast with Remote Locking System
- Allows the operator to switch between operating the Pneumatic Mast with Remote Locking System at the control box or with the HHRC
- Installs between the air supply and the mast
- Indicates the mast pressure in psi
- Has green LEDs that illuminate to indicate when the control system has power and when the base tube locks are unlocked
- P/N: 5572601 or 5572602: Requires 9-40 VDC and has a 3 Amp draw
- P/N: 5572603 or 5572604: Requires 24 VDC and has a 3 Amp draw
- Does not include an air supply



Figure 3-9 Control Box (Not to Scale)

The HHRC (Figure 3-10):

- Allows the operator to control the Pneumatic Mast with Remote Locking System from a distance (approximately 25 ft. from the control box).
- Connects to the control box
- Has green LEDs that illuminate to indicate when the control system has power and when the base tube locks are unlocked

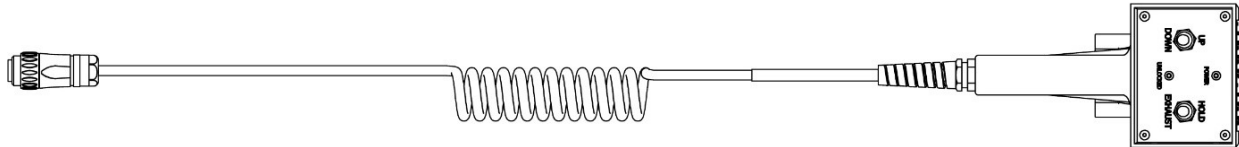

Figure 3-10 HHRC (Not to Scale)

The power cable assembly (Figure 3-11) is used to connect customer power to the control box.



Figure 3-11 Power Cable Assembly (Not to Scale)

The sensor cable (Figure 3-12) is used to connect the reed switch on base tube air cylinders to the control box.



Figure 3-12 Sensor Cable (Not to Scale)

3.3.3 Pneumatic System Options (Sold Separately)

The pneumatic system refers to a means of safely pressurizing and depressurizing the mast. Components of the hardware bag (Section 3.3.1.1) are provided to connect the air supply (by way of the control box) to the air inlet port. A CE rated pneumatic system shall be selected for use in European Member States.

The air supply to operate the mast:

- May be provided by an air compressor or other source of clean, dry air
- Must supply 15 psi minimum for the locks
- Must supply 3 CFM minimum for the mast
- Should be regulated not to exceed the maximum operating pressure of 35 psi (241 kPa) for the mast at any time

Contact The Will-Burt Company for information on our air compressor and pneumatic system options.

3.3.4 Mounting Hardware Options (Sold Separately)

Mounting hardware is used to secure the mast in place.

Possible options for the mounting hardware include:

- Base Plate Options
 - Non-Rotatable Base Plate
 - Rotatable Hardware Kits
- Support Bracket Options
 - External Support Bracket
 - Internal (Roof) Mounting Kit
- Shelf Bracket

3.3.4.1 Base Plate Options

The base plate is used to stabilize the mast and to provide a means of securing the mast to a mounting surface.

Base plate options include:

- Non-Rotatable Base Plates
- Rotatable Hardware Kits

Non-Rotatable Base Plate

The non-rotatable base plate is used to stabilize the mast and to provide a means of securing the mast to a mounting surface. The non-rotatable base plate (Figure 3-13) is a square plate with countersunk holes that match threaded holes on the base tube.

Non-rotatable base plates for Heavy Duty masts typically have a hole in the center of the base plate to allow for the option of routing air to the bottom of the base tube. Non-rotatable base plates for Super Heavy Duty and Ultra Heavy Duty masts typically do not have the center hole.

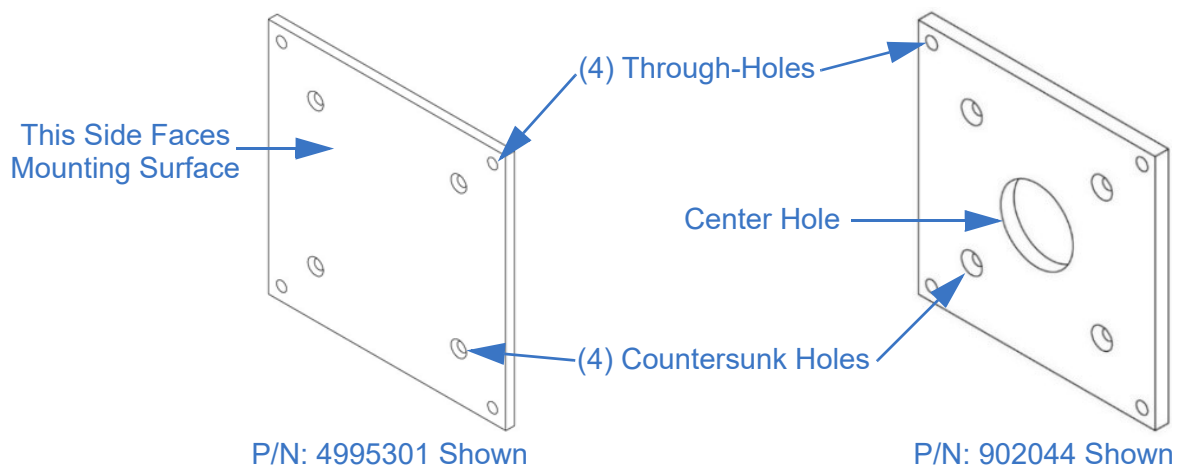

Figure 3-13 Non-Rotatable Base Plate (P/N: 4995301 and 902044 Shown)

Screws from the hardware bag (Section 3.3.1.1) can be used to attach the non-rotating base plate to the base of the mast. Bolts, nuts, and washers from the hardware bag are sized for the through-holes in the corners of the base plate so the mast can be secured to a mounting surface.

For more information on non-rotatable base plate options, see www.willburt.com.

Rotatable Hardware Kits

In addition to stabilizing and securing the mast to a mounting surface, the rotatable base plate (Figure 3-14) and turning handles (Figure 3-15) enable the mast to be rotated. The exact configuration of the rotatable base plate may vary.

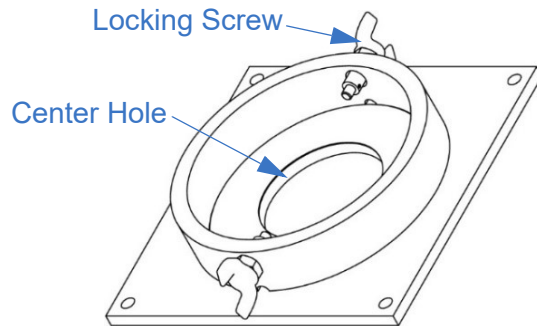

*Figure 3-14 Rotatable Base Plate Assembly
(P/N: 5074601 Shown)*



*Figure 3-15 Turning Handles Assembly
(P/N: 908174 Shown)*

In general, the rotatable hardware kit includes:

- A Rotatable Base Plate Assembly
- A Turning Handles Assembly
- An Instruction Sheet

The turning handles assembly:

- Wraps around the base tube and is secured with hardware included in the kit
- Aids the operator in rotating the mast into position

A hole in the center of the rotatable base plate (Figure 3-14) allows the option of routing air to the bottom of the base tube.

Note: The rotatable base plate assembly for a Super Heavy Duty mast does not use turning handles. Instead, rotating Super Heavy Duty masts have four holes spaced 90° apart in the tube head where a customer-supplied rod can be inserted to provide leverage to turn the mast.

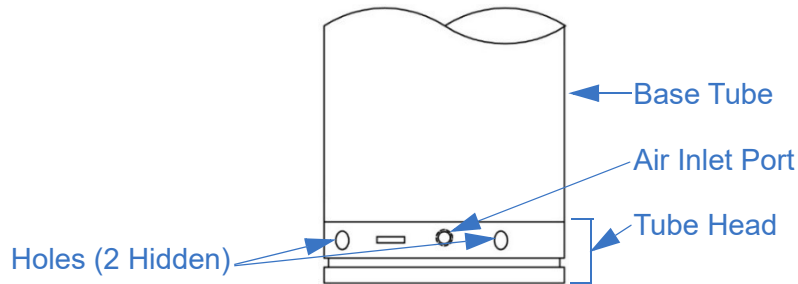

Figure 3-16 Bottom of Rotatable Super Heavy Duty Mast (P/N: 909426 Shown)

For more information on rotatable hardware kit options, see www.willburt.com.

For more information on the installation and operation of these base plate options, contact The Will-Burt Company.

3.3.4.2 Support Bracket Options

The support bracket is used to secure the mast to a support structure.

The support bracket can be an:

- External Support Bracket
- Internal (Roof) Mounting Kit

External Support Bracket

The external support bracket (Figure 3-17, Figure 3-18, and Figure 3-19) is used to position and support the mast.

The external support bracket is constructed from:

- (1) Support bracket weldment which positions the support brackets away from the support structure
- (2) Support bracket clamps which close around the base tube and are bolted together to hold the mast against the mounting structure
- Bearing strips attached inside the support brackets which protects the base tube from being scraped by the support brackets and allows the mast to be rotated
- Hardware to secure the assembly together

Note: External support brackets for masts 9 inch (229 mm) base tube diameters have a brace across the stand-off.

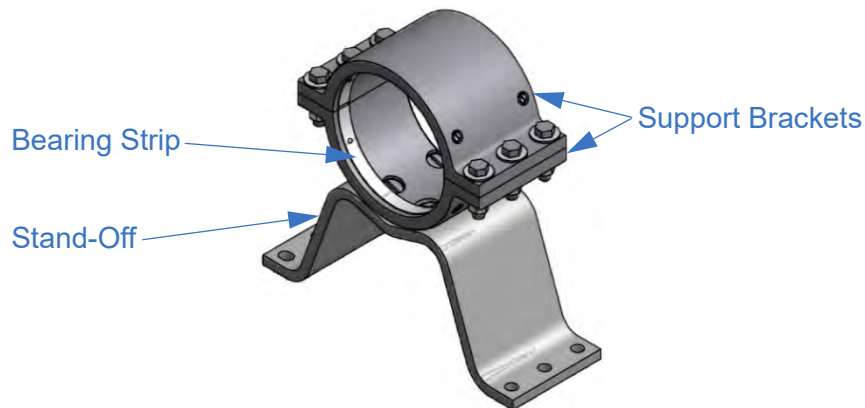
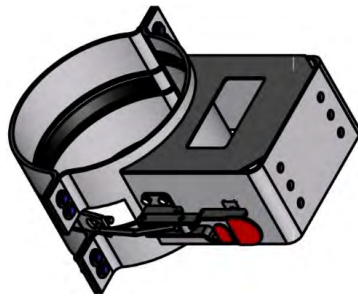

Figure 3-17 Heavy Duty External Support Bracket (P/N: 4443601 Shown)

If the support bracket is too tight and hindering rotation processes, customer-provided shims may need to be added to allow for slight variation.

External support brackets are also available for Super Heavy Duty masts (Figure 3-18).



P/N: 909984 Shown

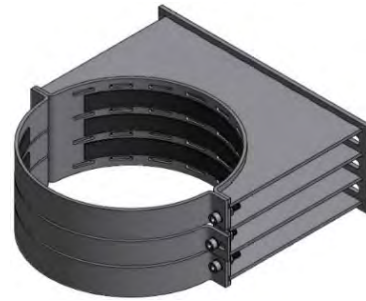

P/N: 4894901 Shown

Figure 3-18 Super Heavy Duty External Support Brackets

External support brackets are also available for Ultra Heavy Duty masts (Figure 3-19). Ultra Heavy Duty support brackets contain shims and a washer plate which are used to allow for slight variation between mast tubes.

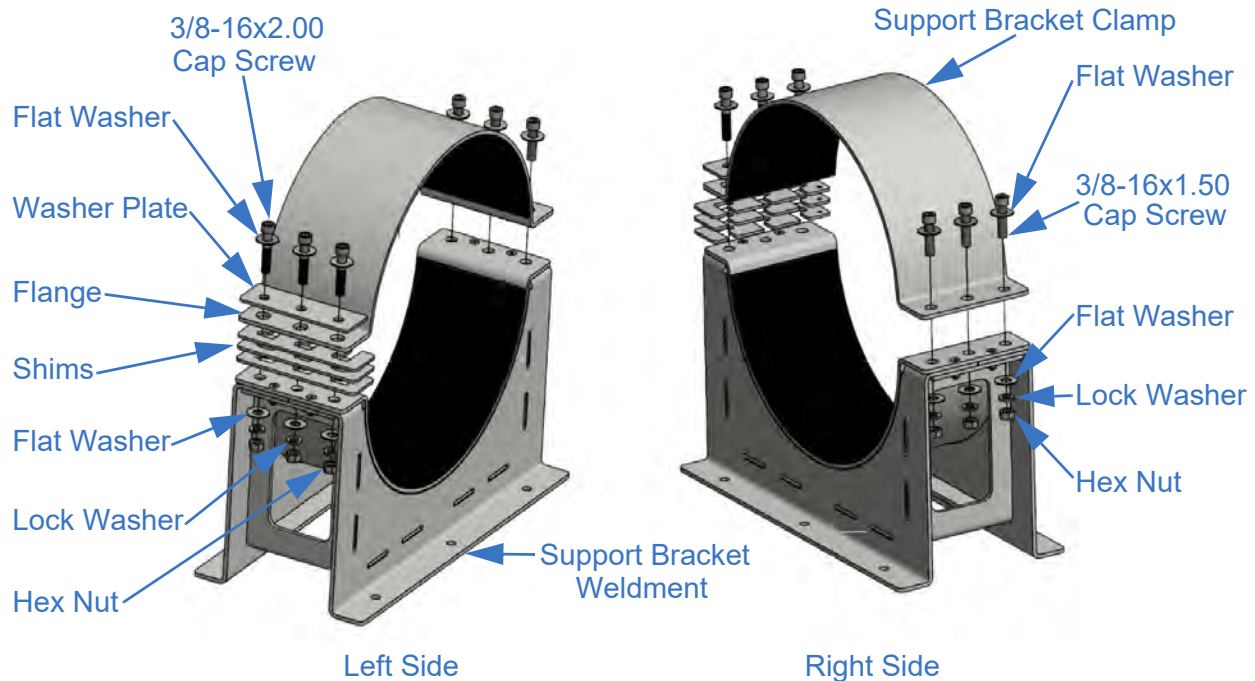

Figure 3-19 Ultra Heavy Duty External Support Bracket (P/N: 4989201 Shown)

For more information on the external support bracket, see www.willburt.com.

Internal (Roof) Mounting Kit

The internal mounting kit (P/N: 5476101) (Figure 3-23) contains the hardware used to position and support an internally mounted mast. Internal mounting kits are available for both non-rotatable and rotatable masts. Customer-supplied ¼ inch (M6) bolts, lock washers, and hex nuts shall be used as fasteners. Bolt length depends on the specific application and is to be determined by the customer.

Internal mounting kits for Heavy Duty masts include:

- (1) Weather Bonnet
- (2) Gaskets
- (1) Bearing Strip
- (1) Ceiling Plate
- (1) Roof Flange
- (1) O-Ring

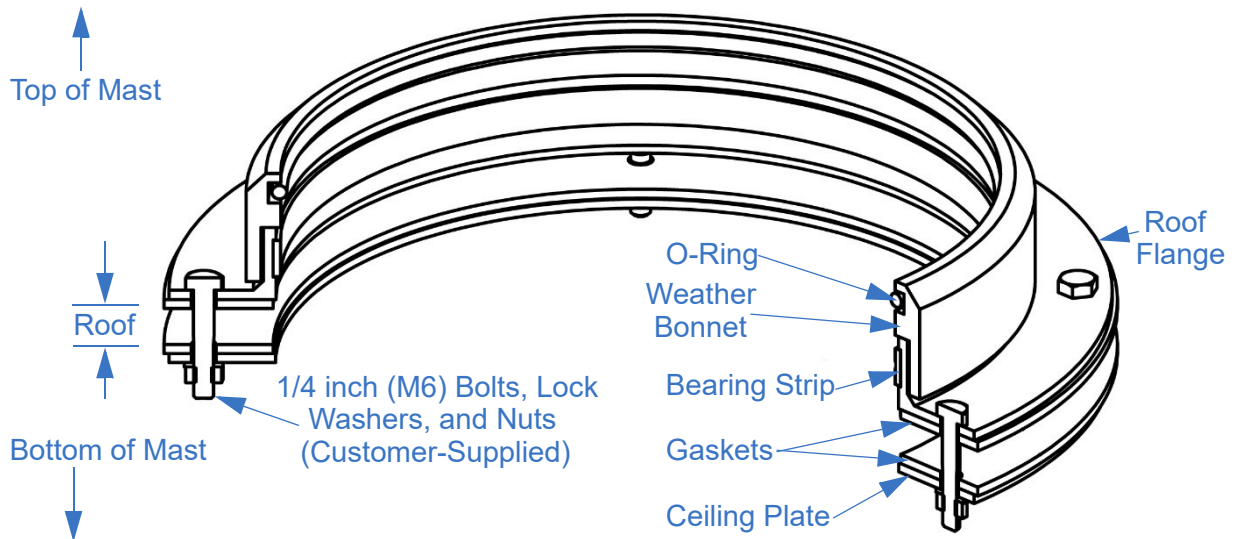

Figure 3-20 Internal Mounting Kit for Heavy Duty Masts (P/N: 905733 Shown)

Internal Mounting Kits for non-rotating Super Heavy Duty masts include:

- (1) Roof Ring
- (2) Gaskets
- (1) Bearing Strip
- (1) Ceiling Plate
- (1) Retaining Ring
- (1) O-Ring

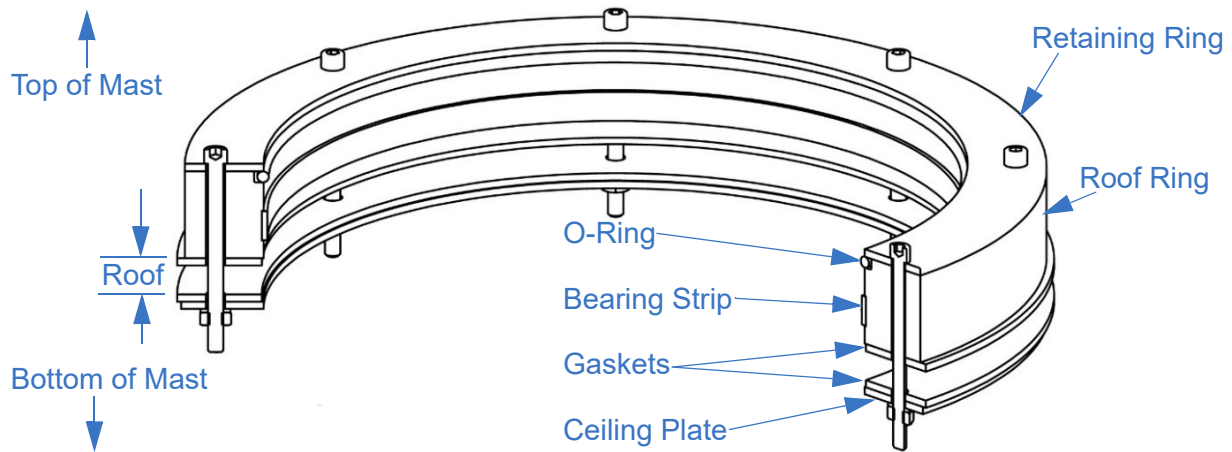

Figure 3-21 Internal Mounting Kit for Non-Rotating Super Heavy Duty Masts (P/N: 910784 Shown)

Internal Mounting Kits for rotating Super Heavy Duty masts have the same components as the Internal Mounting Kits for non-rotating masts, but remove the O-Ring and add the flashing kit.

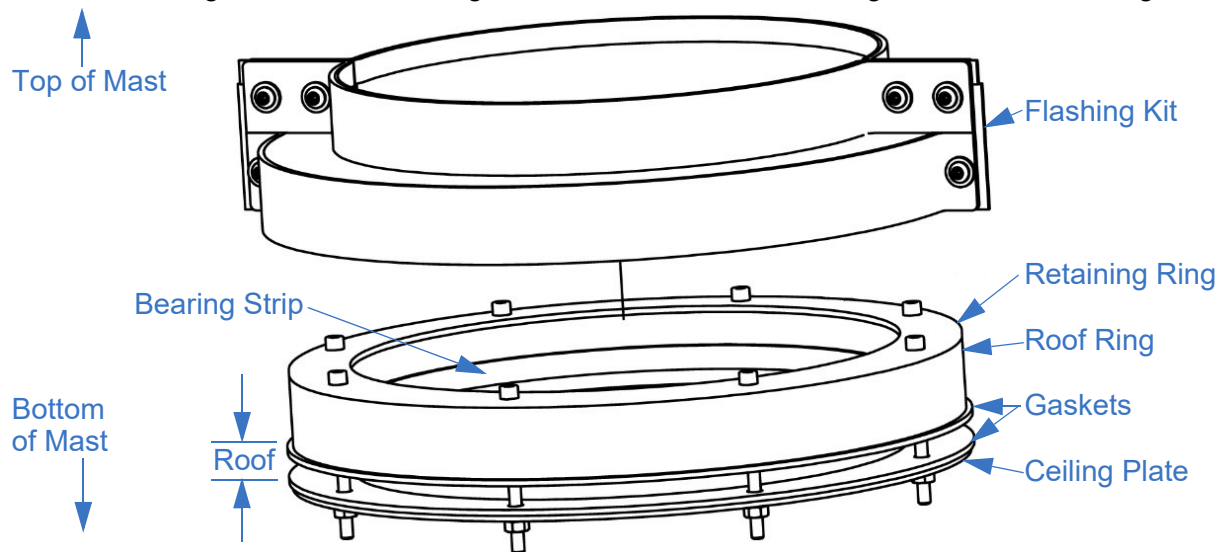

Figure 3-22 Internal Mounting Kit for Rotating Super Heavy Duty Masts (P/N: 4915901 Shown)

Internal Mounting Kits for the Ultra Heavy Duty Locking mast include:

- (1) Roof Ring
- (2) Gaskets
- (1) Bearing Strip
- (1) Ceiling Plate
- (1) Retaining Ring
- (1) O-Ring
- (8) $\frac{3}{8}$ -16x3.50 Bolts
- (16) $\frac{3}{8}$ x1.0 Flat Washers
- (8) $\frac{3}{8}$ -16 Nyloc Nuts

Note: Included hardware is sized for a $\frac{1}{4}$ inch (6.35 mm) roof. If a thicker roof is present, the customer must supply appropriate hardware.

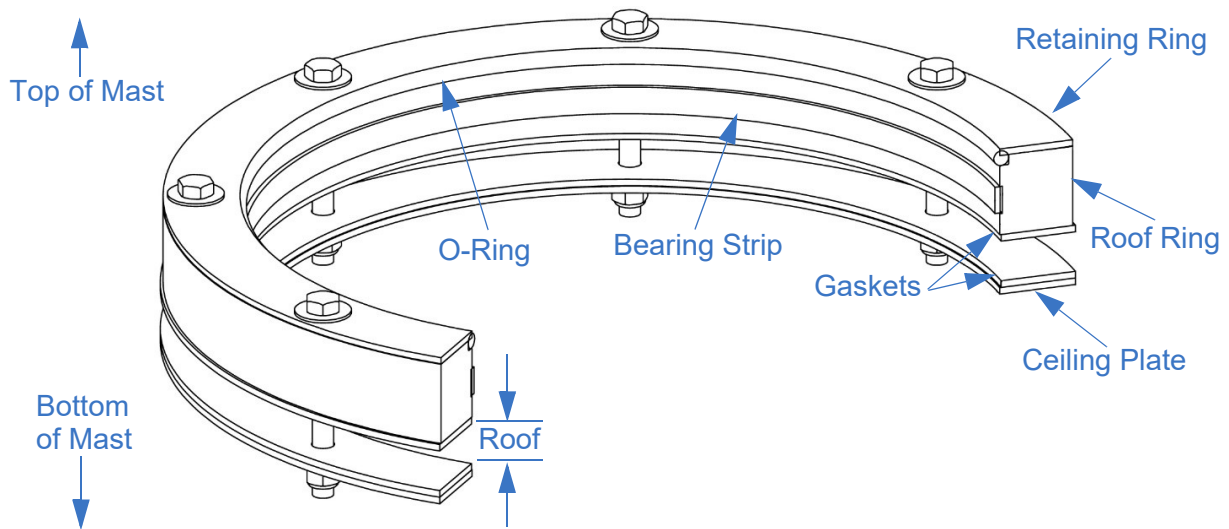

Figure 3-23 Ultra Heavy Duty Locking Internal Mounting Kit (P/N: 5476101)

For more information on internal mounting kit options, see www.willburt.com.

3.3.4.3 Shelf Bracket

The shelf bracket can be bolted into a support structure and used to position and support an externally mounted mast. Shelf brackets are available for use with both non-rotatable base plates and rotatable base plates and for various sized masts. When using the shelf bracket, the shelf bracket becomes the mounting surface for the base plate.

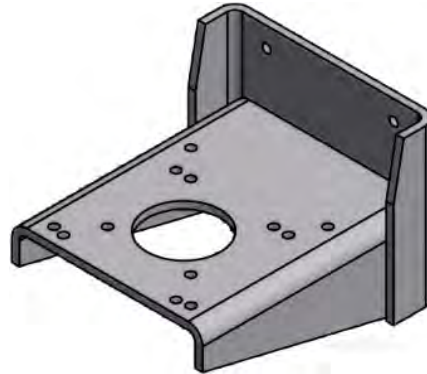
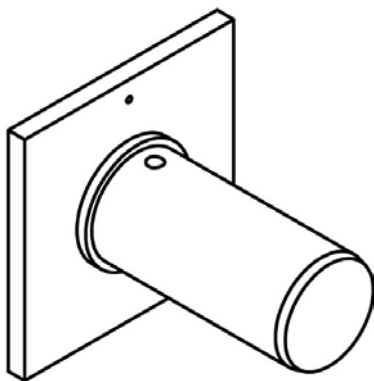

Figure 3-24 Shelf Bracket (P/N: 4434101 Shown)

For more information on the shelf bracket options, see www.willburt.com.

3.3.5 Payload Platform and Stub Adaptor Options (Sold Separately)

Payload platforms and stub adaptors (Figure 3-25) attach to the top of the mast and are used to secure and support the payload during operation. Payload platforms and stub adaptors come in varying sizes and configurations. It is possible to guy directly to some payload platforms and stub adaptors.



Payload Platform (P/N: 915343 Shown)

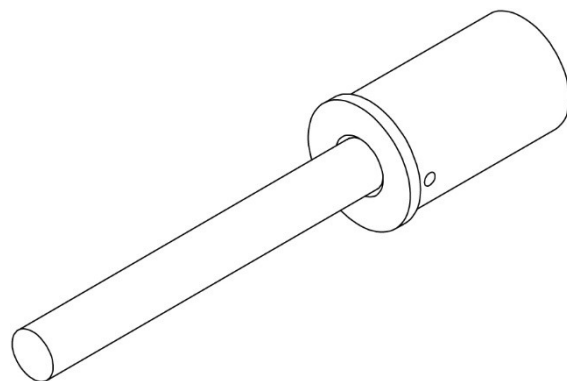

Stub Adaptor (P/N: 910353 Shown)

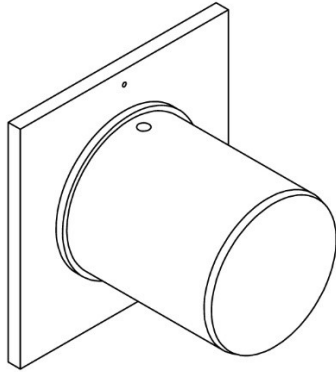

Payload Platform (P/N: 4051601 Shown)

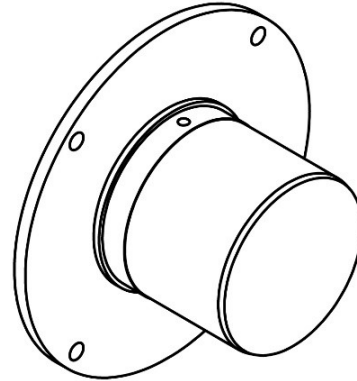

Payload Platform (P/N: 4079501 Shown)

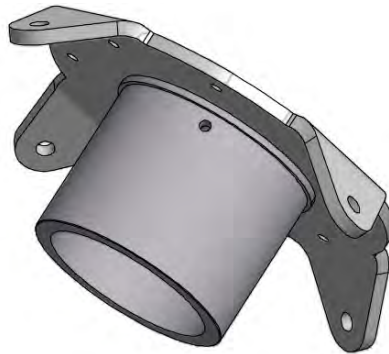

Payload Platform (P/N: 5002501 Shown)

Figure 3-25 Payload Platform Examples (Not to Scale)

Payload platforms are available both with through-holes to allow for quick installation of customer payloads, and without through-holes to allow the customer to drill through-holes to match payload-specific mounting hole patterns.

For partial extension applications (Section 6.3.2.1) or applications transporting the mast horizontally (Section 7.1), The Will-Burt Company recommends the use of an optional hold down platform (ordered separately) with the hold down leashes (which ship with the mast).

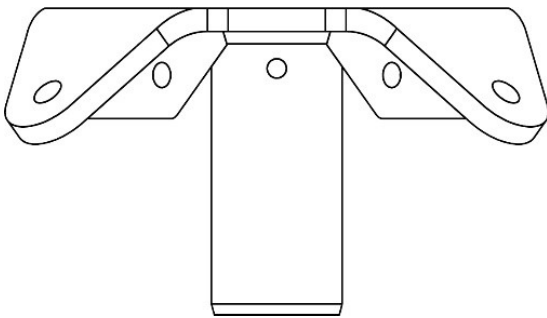

Hold Down Platform (P/N: 55451xx Shown)

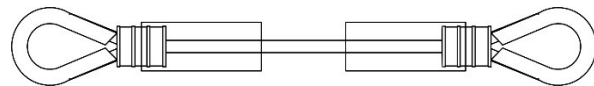

Hold Down Leash (P/N: 55191xx Shown)

Figure 3-26 Hold Down Platform and Hold Down Leash (Not to Scale)

Table 3-4 lists available hold down platforms.

Table 3-4 Hold Down Platforms

Description	Part Number*
Hold Down Platform for 3.00" Top Tube	5545101-xxxx
Hold Down Platform for 3.75" Top Tube	5545102-xxxx
Hold Down Platform for 4.50" Top Tube	5545103-xxxx
Hold Down Platform for 5.25" Top Tube	5511501-xxxx
Hold Down Platform for 6.00" Top Tube	5511502-xxxx
Hold Down Platform for 6.75" Top Tube	5511503-xxxx
Hold Down Platform for 7.50" Top Tube	5511504-xxxx
Hold Down Platform for 8.25" Top Tube	5511505-xxxx
* -xxxx represents the finish code. For example, AN01 denotes a platform with a clear anodize finish.	

Contact The Will-Burt Company for additional information on available payload platforms.

3.3.6 Guy Line Options (Sold Separately)

Guy line kits are used to further stabilize the mast by resisting environmental conditions that may cause tip-over and horizontal payload moment. Guy lines attach to guy lugs, which are located on the collars of the mast. Use of a guy line kit is required for the operation of some of the taller model masts. Use of a guy line kit may be required for customer-specific payloads or to achieve specific survival wind speeds. Consult The Will-Burt Company’s engineering team.

Note: Not all masts have guy lugs. Before considering a guy line kit, make sure your mast is guy line compatible.

The exact configuration of the guy kit will vary based on the mast configuration and environmental requirements. Some guy kits require a payload platform or stub adaptor that can be directly guyed.

Components may include:

- Guy Line Assemblies
- Ground Anchors
- A Ground Anchor Location Drawing

For additional information on guy kits, see www.willburt.com.

3.3.7 Additional Accessory Options (Sold Separately)

The Will-Burt Company provides a number of additional accessory options (Table 3-5) for the mast system.

Table 3-5 Additional Accessory Options

Accessory	Used To:
Pneumatic Mast Antifreeze Kit (P/N: 4725801)	Weatherize pneumatic masts in extremely harsh environmental conditions.
D-TEC® Safety System	Provide overhead power line and above the mast illumination.
PositionIt™	Remotely pan and tilt a payload.
Cable Guide Ring Kits	Manage cables and guy lines
Intermediate Tube Clamps	Assist in attaching a payload on an intermediate tube.
Hand Pump (P/N: 5050101)	Deploy the mast where electric or pneumatic power is not available.
Filter Regulator Lubricator (P/N: 900484)	Filter contaminants, regulate air pressure, and lubricate components in a controlled manner.
Filter Lubricator (P/N: 900634)	Filter contaminants and lubricate components in a controlled manner.
External Wipers	Additional protection against sand and dust.

For more information on these and other additional accessory options, or customized solutions to customer-specific scenarios, see www.willburt.com.

4 Technical Data

This section describes specifications for standard catalog masts only. Masts with other heights and capabilities are available.

This section describes specifications for Pneumatic Masts with Remote Locking Systems as follows:

- Specifications for all Pneumatic Masts with Remote Locking Systems (Section 4.1)
- Heavy Duty Locking Masts (Section 4.2)
- Super Heavy Duty Locking Masts (Section 4.3)
- Ultra Heavy Duty Locking Masts (Section 4.4)
- Installation Specifications (Section 4.5)

The model numbers listed in this section are for catalog masts with a clear anodized finish only. Masts with other heights, capacities, and finishes are available. For more information on additional mast sizes, capabilities, and finishes, see www.willburt.com.

4.1 Specifications for all Pneumatic Masts with Remote Locking Systems

See Mast Wind Load Capacity (Section 10.4) for wind load specifications for various masts. If the mast model is not listed, contact The Will-Burt Company. If payload extends beyond the boundaries defined for the wind analysis, contact The Will-Burt Company.

Mast Storage Temperature: -40°C to +70°C (-40°F to 158°F)

Maximum Altitude Above Sea Level: 4572 meters (15,000 feet)

Airborn Noise Emissions are as follows per ISO 3744:2010 when compared to a certified similar product. (A-weighted sound pressure level: <70 dB(A); C-weighted instantaneous pres level: <79.7 dB; A-weighted sound power level: 80 dB(A) (note this is for the mast and not the air delivery system).

Refer to Section 10.4 for mast wind load and sail area ratings.

Deployment and retraction wind speeds are payload dependent, however, the mast can typically be deployed and retracted in wind speeds up to 25 mph (40 km/h) when the mast is deployed within the maximum payload and deployment angle specifications. Check with The Will-Burt Company's Engineering team for additional customer specific loading scenarios.

4.2 Heavy Duty Locking Masts

This section lists specifications for Heavy Duty Locking masts.

Table 4-1 Heavy Duty Mast Part and Model Numbers

*P/N	M/N
906043	7-30
906045	7-42
906051	10-60
*Part numbers listed for masts with a clear anodize finish only. Additional finishes and options available.	

Table 4-2 Heavy Duty Locking Mast Specifications

Heavy Duty	7-30	7-42	10-60
Extended Height (ft / m)	29.1 / 8.86	41.2 / 12.57	59.8 / 18.21
Nested Height (ft / m)	7 / 2.13	7.8 / 2.36	10 / 3.07
Approximate Mast Weight (lb. / kg)	125 / 57	235 / 107	330 / 150
Payload Capacity (lb. / kg)	200 / 90.7	200 / 90.7	300 / 136.1
Number of Sections	6	9	8
Tube Diameter Range (in / mm)	6.75-3 / 171-76	9-3 / 229-76	9-3.75 / 229-95
Collar Type	Locking with Remote Locking System		
Operating Temperature (°C / °F)	-20°C to 60°C / -4°F to 140°F		
Storage Temperature (°C / °F)	-40°C to +70°C / -40°F to 158°F		
Maximum Altitude Above Sea Level (ft / m)	15,000 feet / 4572 meters		
Maximum Operating Pressure for Mast (psig / bar)	35 / 2.4		
Maximum Operating Pressure Control Box Can Handle	140 psi		
Minimum Operating Pressure for Locks	20 psi		
Guying Required	Optional		
Airborn Noise Emissions Per EN ISO 3744:2010	equivalent A-weighted sound pressure level at the operating position is less than 70 dB(A)		

Table 4-2 Heavy Duty Locking Mast Specifications (Continued)

Heavy Duty	7-30	7-42	10-60
<p>Note:</p> <ol style="list-style-type: none">1. Tube Diameter listed as Base Tube Diameter – Top Tube Diameter2. Dimensions and specifications provided are for reference only and are not intended for vehicle design purposes3. Specifications may be subject to change without notice4. Payload Capacity assumes:<ul style="list-style-type: none">• 12 inch maximum offset payload from mast centerline• Mast deployment angle for masts extended up to 60 ft. (18.2 m) is 0° to 5°.• Not applicable to internally wired masts			

4.3 Super Heavy Duty Locking Masts

This section lists specifications for Super Heavy Duty Locking masts.

Table 4-3 Super Heavy Duty Mast Part and Model Numbers

*P/N	M/N
909959	9-50
909426	10.3-60

*Part numbers listed for masts with a clear anodize finish only. Additional finishes and options available.

Table 4-4 Super Heavy Duty Locking Mast Specifications

Super Heavy Duty	9-50	10.3-60
Extended Height (ft / m)	50.4 / 15.37	60.5 / 18.44
Nested Height (ft / m)	9.15 / 2.79	10.4 / 3.18
Approximate Mast Weight (lb. / kg)	500 / 227	500 / 227
Payload Capacity (lb. / kg)	530 / 240.4	530 / 240.4
Number of Sections	8	8
Tube Diameter Range (in / mm)	11.25–5.25 / 286–134	11.25–5.25 / 286–134
Collar Type	Locking with Remote Locking System	
Operating Temperature (°C / °F)	-20°C to 60°C / -4°F to 140°F	
Storage Temperature (°C / °F)	-40°C to +70°C / -40°F to 158°F	
Maximum Altitude Above Sea Level (ft / m)	15,000 feet / 4572 meters	
Maximum Operating Pressure for Mast (psig / bar)	35 / 2.4	
Maximum Operating Pressure Control Box Can Handle	140 psi	
Minimum Operating Pressure for Locks	20 psi	
Guying Required	Optional	
Airborn Noise Emissions Per EN ISO 3744:2010	equivalent A-weighted sound pressure level at the operating position is less than 70 dB(A)	

Table 4-4 Super Heavy Duty Locking Mast Specifications (Continued)

Super Heavy Duty	9-50	10.3-60
<p>Note:</p> <ol style="list-style-type: none">1. Tube Diameter listed as Base Tube Diameter – Top Tube Diameter2. Dimensions and specifications provided are for reference only and are not intended for vehicle design purposes3. Specifications may be subject to change without notice4. Payload Capacity assumes:<ul style="list-style-type: none">• 12 inch maximum offset payload from mast centerline• Mast deployment angle for masts extended up to 60 ft. (18.2 m) is 0° to 5°.• Not applicable to internally wired masts		

4.4 Ultra Heavy Duty Locking Masts

This section lists specifications for Ultra Heavy Duty Locking masts.

Table 4-5 Ultra Heavy Duty Locking Mast Part and Model Numbers

*P/N	M/N
710991590	2.7-15
710991201	8-39
710905700	11.3-59
710992000	9.8-65.6
710908000	14.3-80

*Part numbers listed for masts with a clear anodize finish only. Additional finishes and options available. No wipers.

Table 4-6 Ultra Heavy Duty Locking Mast Specifications

Ultra Heavy Duty	2.7-15 M	8-39	11.3-59	9.8-65.6	13-70	14.3-80
Extended Height (ft / m)	50.13 / 15.28	39.3 / 12	59 / 18	65.6 / 20	70 / 21.3	79.9 / 24.35
Nested Height (ft / m)	8.74 / 2.67	7.9 / 2.4	11.3 / 3.4	9.8 / 3	13 / 4	14.48 / 4.4
Approximate Mast Weight (lb. / kg)	655 / 297.1	607 / 275	814 / 369	852 / 387	920 / 417	1078 / 489
Payload Capacity (lb. / kg)	680 / 308	980 / 444	1200 / 544	530 / 240	1200 / 544	1200 / 544
Number of Sections	9	8	7	10	7	7
Tube Diameter Range (in / mm)	13.5 - 6.0 / 342.9 - 152.4	13.5-6.75 / 342.9-171.5	13.5-7.5 / 342.9-190.5	13.5-5.25 / 342.9-133.4	13.5-7.5 / 342.9-190.5	13.5 - 7.5 / 342.9 - 190.5
Collar Type	Locking with Remote Locking System					
Operating Temperature (°C / °F)	-4°C to 60°C / -25°F to 140°F					
Storage Temperature (°C / °F)	-40°C to +70°C / -40°F to 158°F					
Maximum Altitude Above Sea Level (ft / m)	15,000 feet / 4572 meters					
Maximum Operating Pressure for Mast (psig / bar)	35 / 2.4					

Table 4-6 Ultra Heavy Duty Locking Mast Specifications (Continued)

Ultra Heavy Duty	2.7-15 M	8-39	11.3-59	9.8-65.6	13-70	14.3-80
Maximum Operating Pressure Control Box Can Handle	140 psi					
Minimum Operating Pressure for Locks	20 psi					
Guying Required	Optional	Optional	Optional	Optional	Required	Required
Airborn Noise Emissions Per EN ISO 3744:2010	equivalent A-weighted sound pressure level at the operating position is less than 70 dB(A)					
<p>Note:</p> <ol style="list-style-type: none"> 1. Tube Diameter listed as Base Tube Diameter – Top Tube Diameter 2. Dimensions and specifications provided are for reference only and are not intended for vehicle design purposes 3. Specifications may be subject to change without notice 4. Payload Capacity assumes: <ul style="list-style-type: none"> • 12 inch maximum offset payload from mast centerline • Mast deployment angle for masts extended up to 60 ft. (18.2 m) is: <ul style="list-style-type: none"> • 0° to 5° for payloads 200 lb. (90.7 kg) or less • 0° to 4° for payloads 200 lb. to 800 lb. (90.7 kg to 362.9 kg) • 0° to 2° for payloads 800 lb. to 1,200 lb. (362.9 kg to 544.3 kg) • Mast deployment angle for masts extended 60 ft. to 80 ft. (18.2 m to 24.4 m) is: <ul style="list-style-type: none"> • 0° to 4° for payloads 600 lb. (272.2 kg) or less • 0° to 1° for payloads 600 to 1,200 lb. (272.2 kg to 544.3 kg) • Not applicable to internally wired masts 						

4.5 Installation Specifications

This section describes installation specifications as follows:

- Mast Installation Specifications (Section 4.5.1)
- Non-Rotating Base Plate Installation Specifications (Section 4.5.2)
- Rotating Base Plate Installation Specifications (Section 4.5.3)
- Turning Handle Assembly Installation Specifications (Section 4.5.4)
- Support Bracket Assembly Installation Specifications (Section 4.5.5)
- Internal Mounting Kit Installation Specifications (Section 4.5.6)
- Shelf Bracket Assembly Installation Specifications (Section 4.5.7)
- Control Box Installation Specifications (Section 4.5.8)

Dimensions and specifications provided are for reference only and are not intended for vehicle design purposes. Depending on the mast system and components being used, the exact design of components may vary. Masts with other heights, capacities, and finishes are available. For more information on additional mast sizes, capabilities, and finishes, see www.willburt.com.

4.5.1 Mast Installation Specifications

Table 4-7 Mast Installation Specifications

		A		B		C	
P/N*	MODEL	inch	mm	inch	mm	inch	mm
Heavy Duty Locking							
906043	7-30	84	2134	68.3	1735	55.3	1405
906045	7-42	92	2337	68.4	1737	49.6	1260
906051	10-60	122	3099	101.1	2568	82.4	2093
Super Heavy Duty Locking							
909959	9-50	110	2794	89.6	2276	66.5	1689
909426	10.3-60	125	3175	104.6	2657	81.5	2070
Ultra Heavy Duty							
710991201	8-39 (2.4-12 m)	95	2413	74 11/16	1897	48 11/16	1237
710905700	11.3-59 (3.4-18 m)	135 13/16	3450	108 ¾	2762	91 13/16	2332
710992000	9.8-65.6 (3-20 m)	118	2997	91 ¾	2330	66 ¾	1686
710908000	14.3-80 (4.4-24 m)	172	4363	153.74	3901	127.76	3245
* Part Numbers for clear anodized finish. Additional finishes are available.							

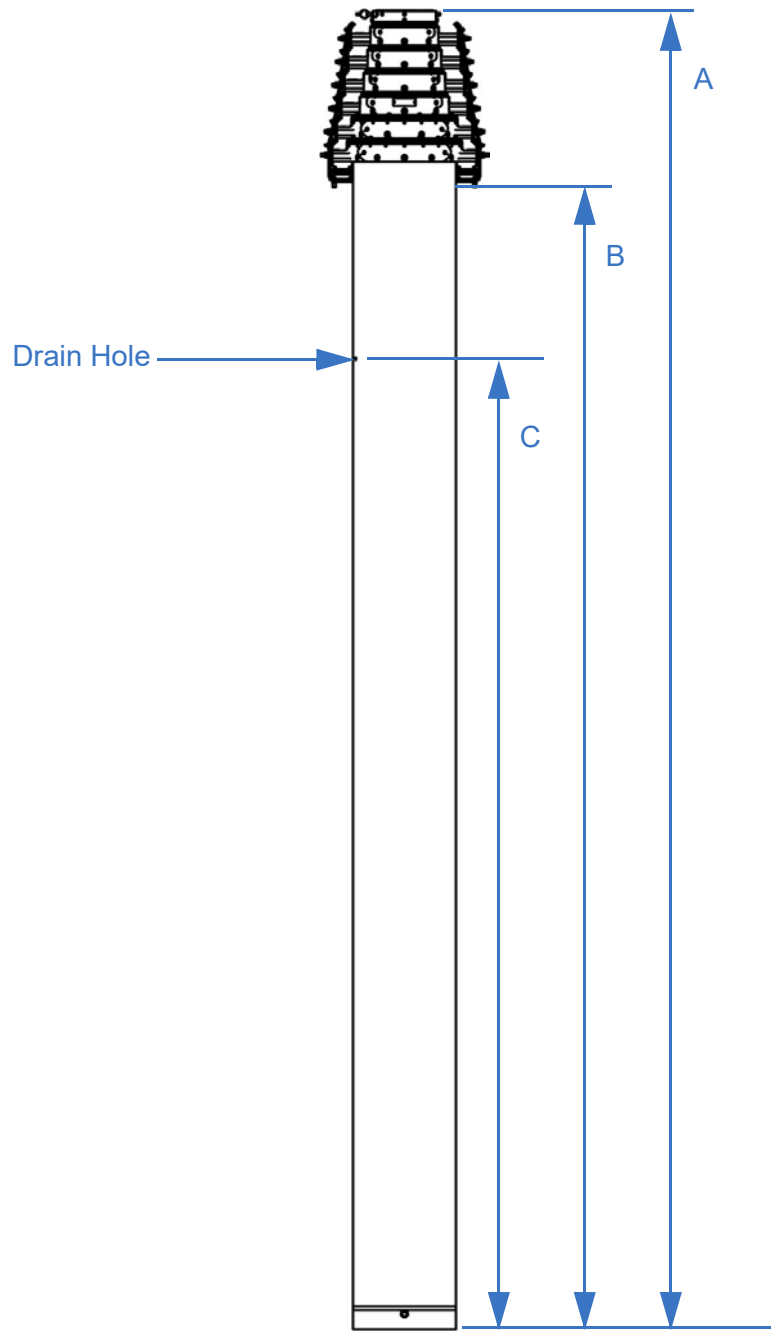

Figure 4-1 Mast Installation Specifications (Not to Scale)

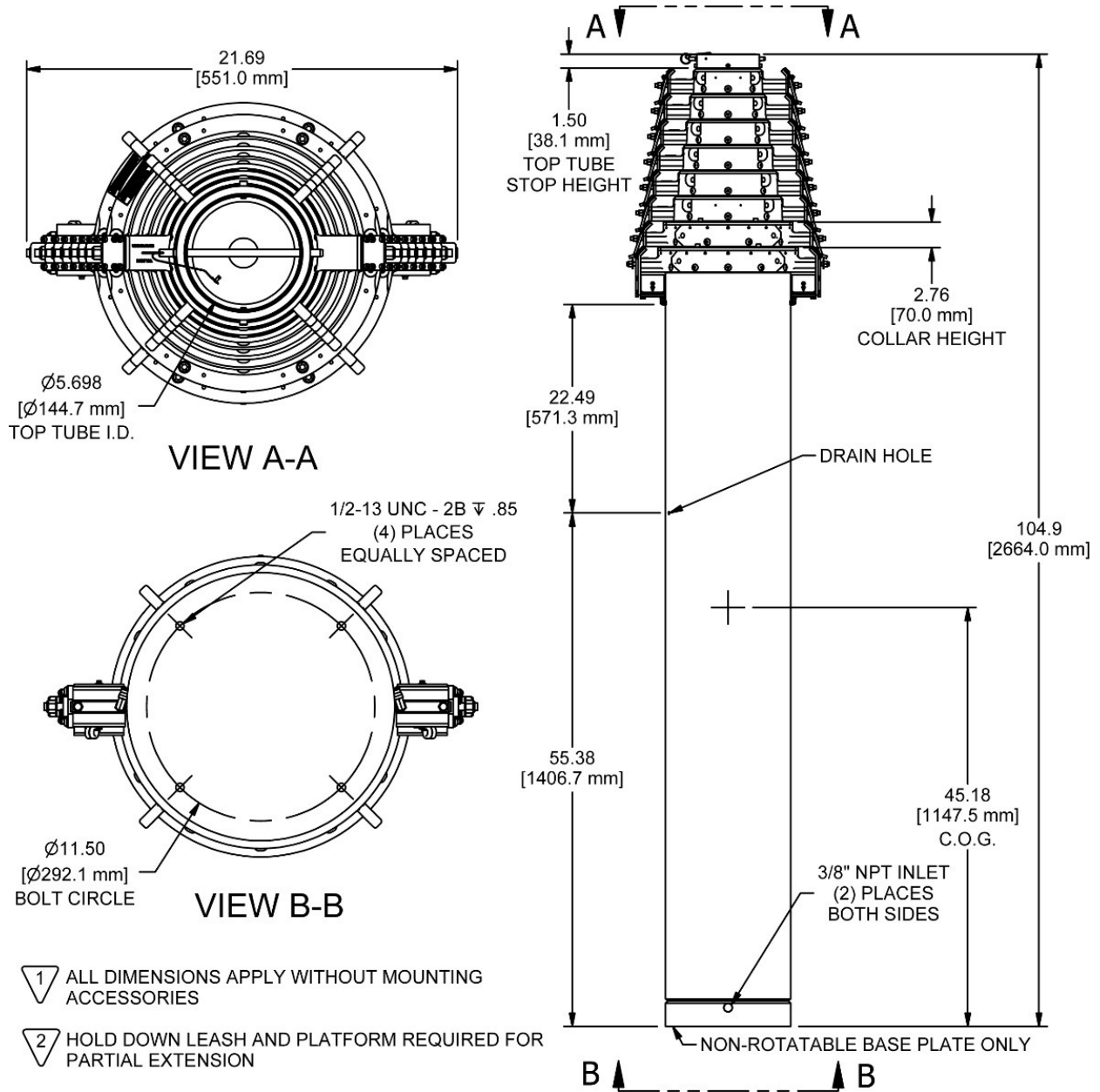

Figure 4-2 Ultra Heavy Duty Mast Installation Specification (P/N: 710991590 Shown)

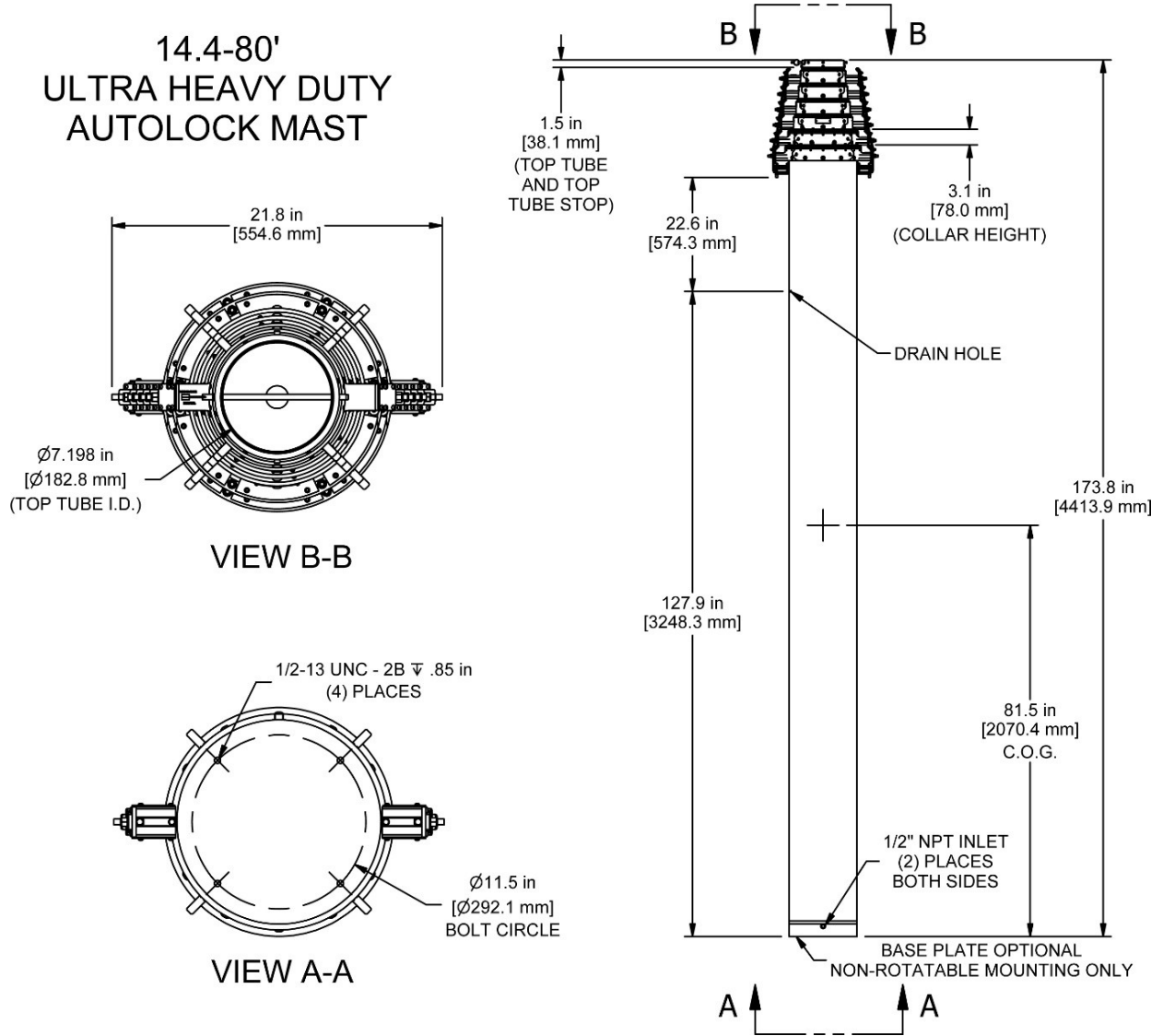

Figure 4-3 Ultra Heavy Duty Mast Installation Specification (P/N: 710908091 Shown)

4.5.2 Non-Rotating Base Plate Installation Specifications

The non-rotating base plate:

- Weighs approximately 9 lb. (4 kg)
- Has the dimensions shown in Table 4-8 / Figure 4-4 and Figure 4-5.

Table 4-8 Non-Rotating Base Plate Installation Specifications

P/N*	Base Tube	A		B		C		D		Ø BCD	
		inch	mm	inch	mm	inch	mm	inch	mm	inch	mm
902363	6 ¾	6 ¾	171	5 ¾	146	7/16	11	0.5	12.7	4.75	120.65
902044	9	9	229	8	203	7/16	11	0.5	12.7	7.0	177.8
909427	11 ¼	12	305	11	279	9/16	14	0.5	12.7	9.5	241.3
4995301	13.5	13.5	343	12	305	9/16	14	0.5	12.7	11.5	292

* Part Numbers for clear anodized finish. Additional finishes are available.

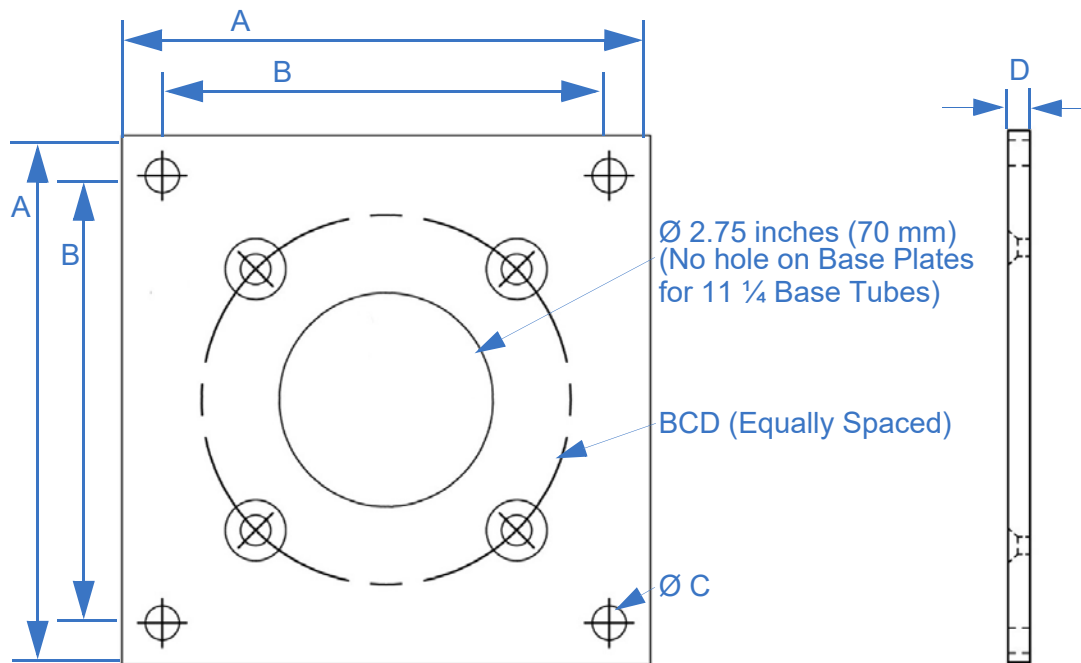

Figure 4-4 Non-Rotating Base Plate Installation Specifications (P/N: 902491 Shown)

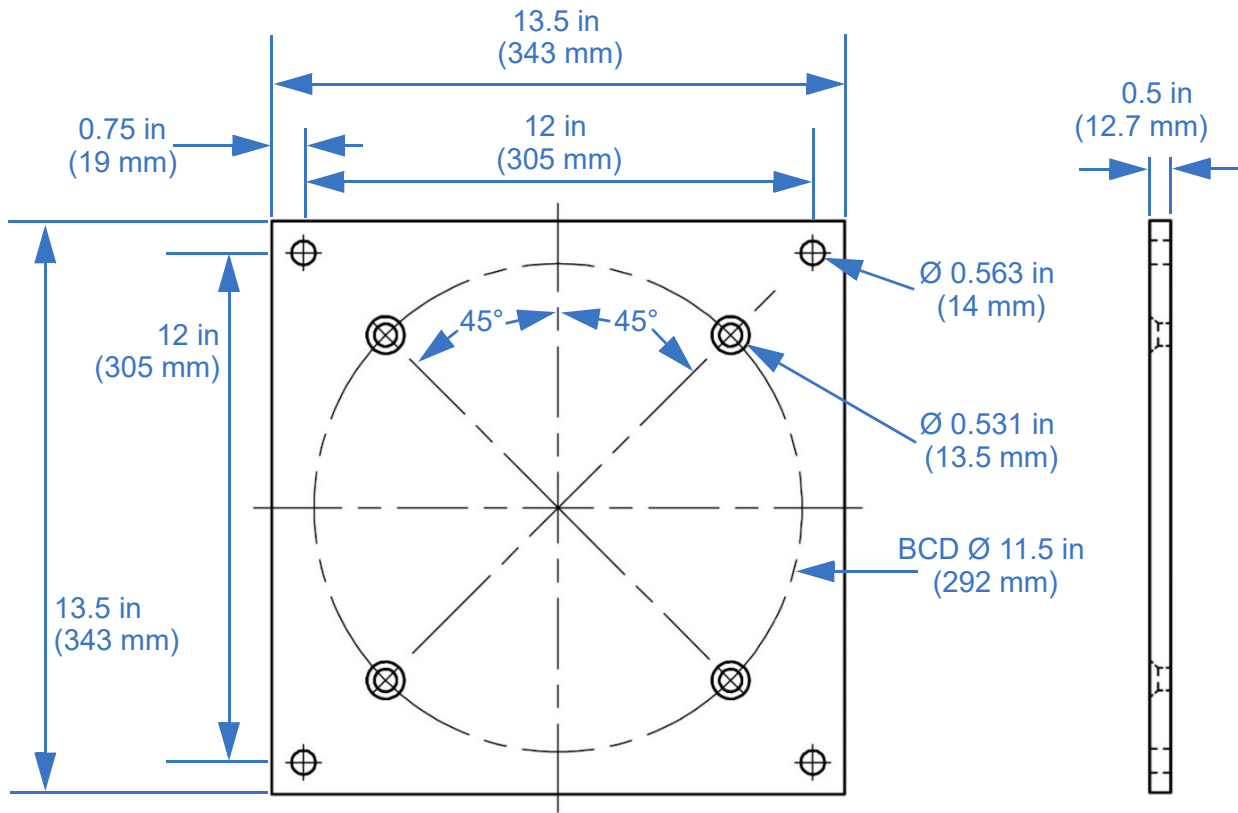

Figure 4-5 Ultra Heavy Duty Non-Rotating Base Plate Installation Specifications (P/N: 4995301 Shown)

Non-rotating base plate P/N: 4995301 has a clear anodize finish. Additional finishes are available.

4.5.3 Rotating Base Plate Installation Specifications

Table 4-9 Rotating Base Plate Installation Specifications

P/N*	Base Tube	A		B		C		D		Est. Weight	
		inch	mm	inch	mm	inch	mm	inch	mm	lb.	kg
902364	6 ¾	9 ¾	248	8.7	222	0.38	9.7	0.4	10	12.4	5.6
902344	9	12	305	11	279	0.38	9.7	0.4	10	20.5	9.3
909983	11 ¼	13	330	11	279	0.50	12.7	0.56	14	12.1	5.5

* Part Numbers for the base plate only and does not include turning handles. Part Numbers for 5, 6 ¾, and 9 inch base plates are for white powder coat finish. Part Number for 11 ¼ inch base plate is for clear anodize finish. Additional finishes are available. The appearance of the 11 ¼ base plate will be slightly different.

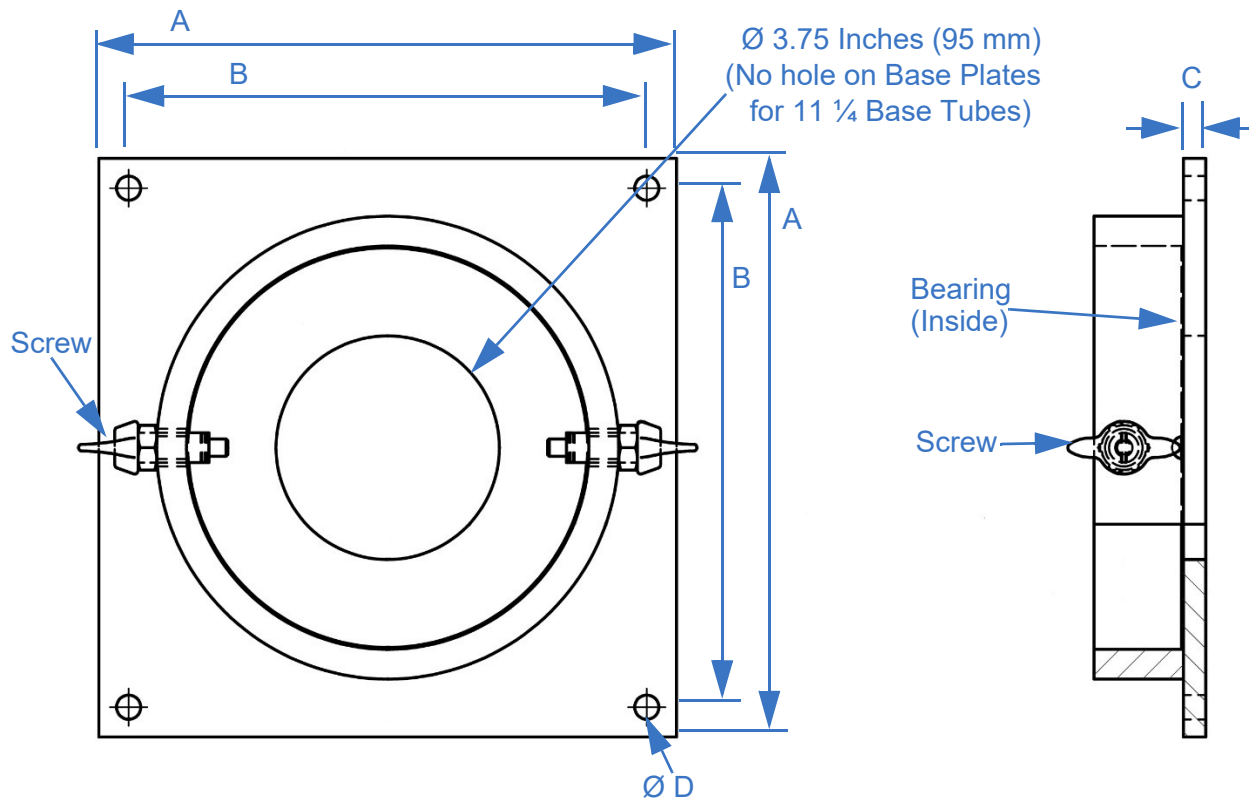

Figure 4-6 Rotating Base Plate Installation Specifications (P/N: 902492 Shown)

4.5.4 Turning Handle Assembly Installation Specifications

Table 4-10 Turning Handle Assembly Installation Specifications

P/N*	Base Tube	A	
		inch	mm
914480	6 ¾	16	406
906813	9	18	457

* Part Number is for the turning handles only and does not include the base plate. Part Numbers listed have a black paint finish. Additional finishes are available.

Note: Rotatable masts with 11 ¼ base tubes do not come standard with turning handles.

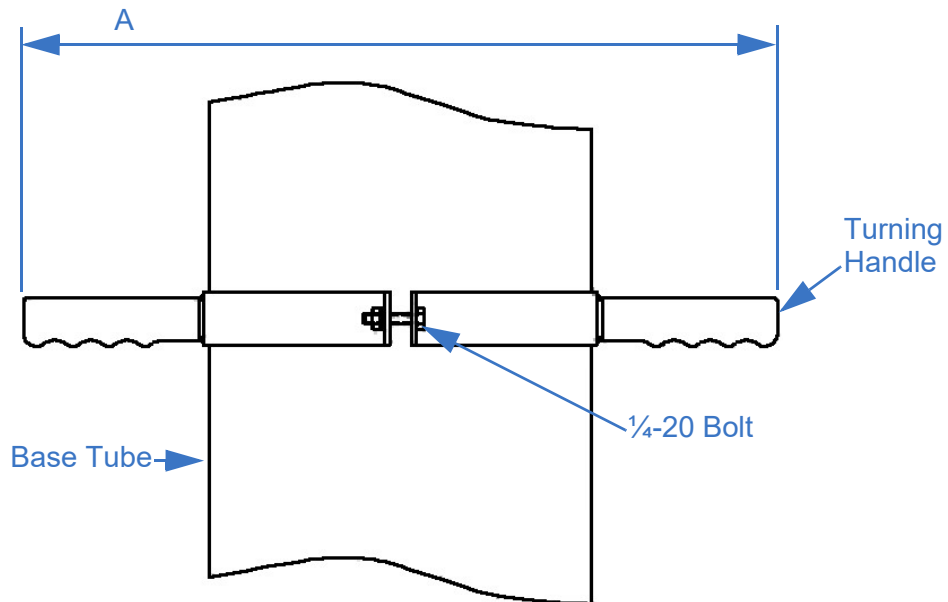

Figure 4-7 Turning Handle Assembly Installation Specifications

4.5.5 Support Bracket Assembly Installation Specifications

Table 4-11 Support Bracket Installation Specifications

P/N*	Base Tube	OD		A		B		Est. Weight	
		inch	mm	inch	mm	inch	mm	lb.	kg
4443605	6 ¾	7 ¾	197	8 ¼	210	12.10	307	6.7	3
4443615	9	10 ½	267	9 ¾	248	13.84	352	12.1	5.5

* Part Numbers for clear anodized finish. Additional finishes are available.

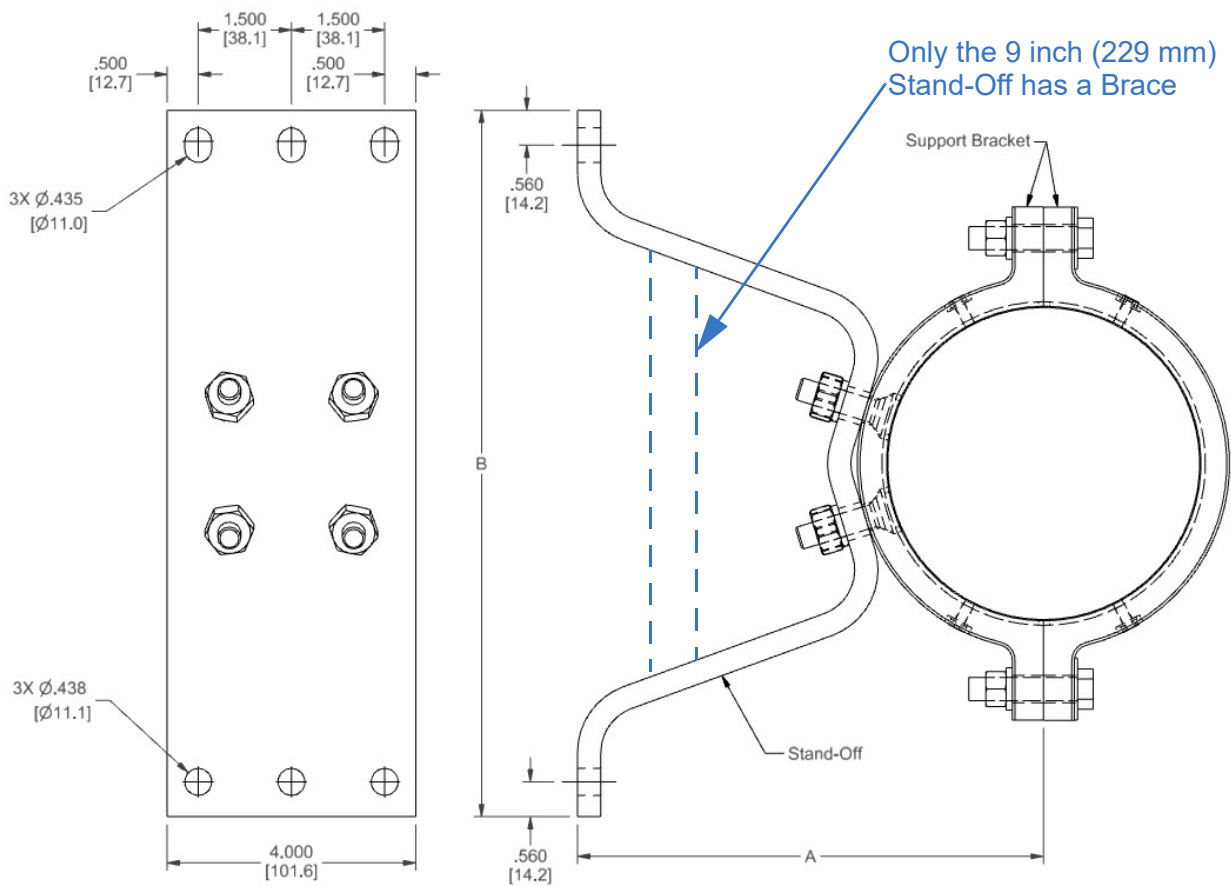
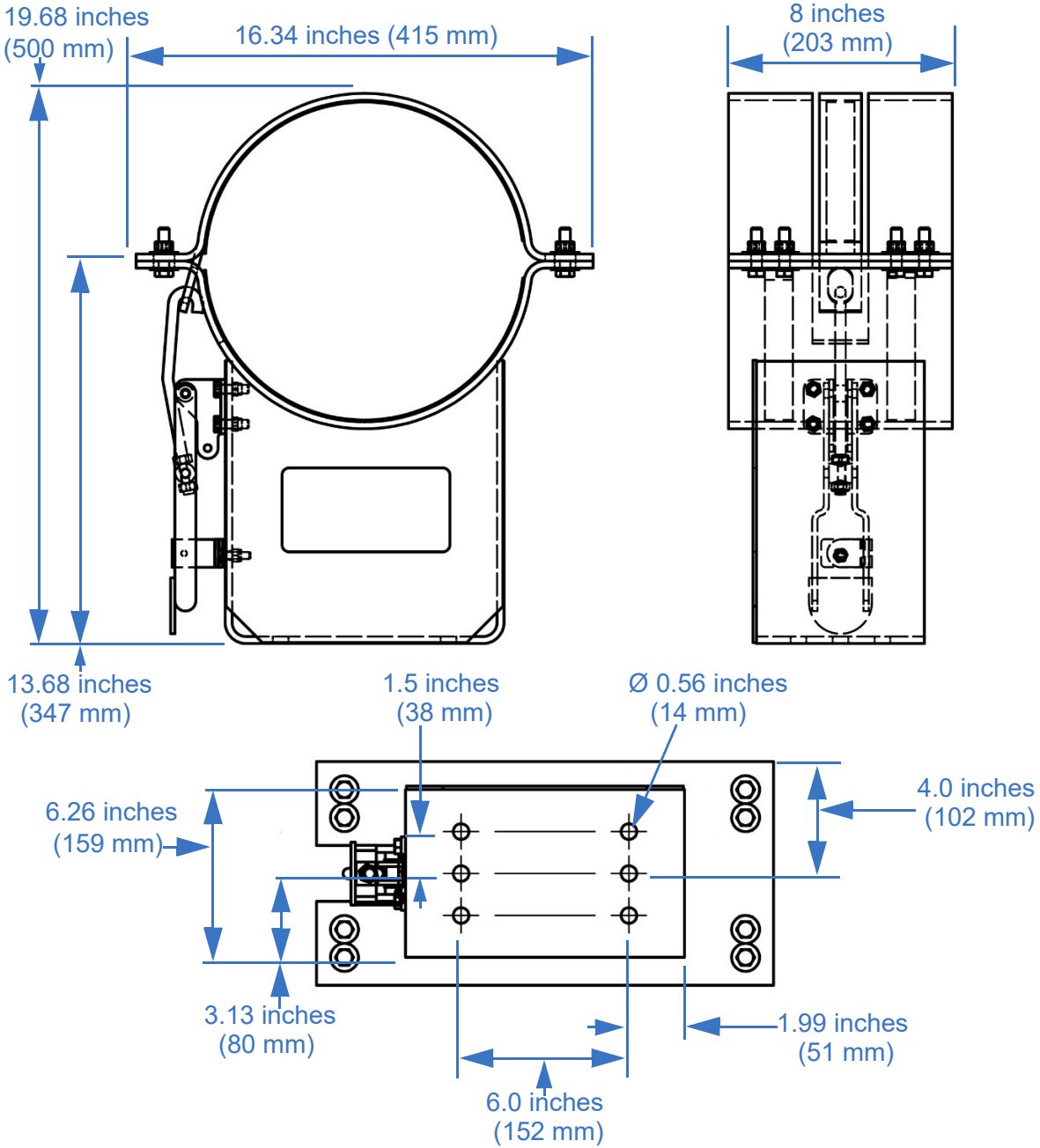

Figure 4-8 Support Bracket Assembly (Heavy Duty) Installation Specifications
(P/N: 4443601 Shown)



*Figure 4-9 Support Bracket Assembly (Super Heavy Duty) Installation Specifications
(P/N: 909984 Shown)*

Note: Part Number 909984 is for a black powder coat finish. Additional finishes are available.

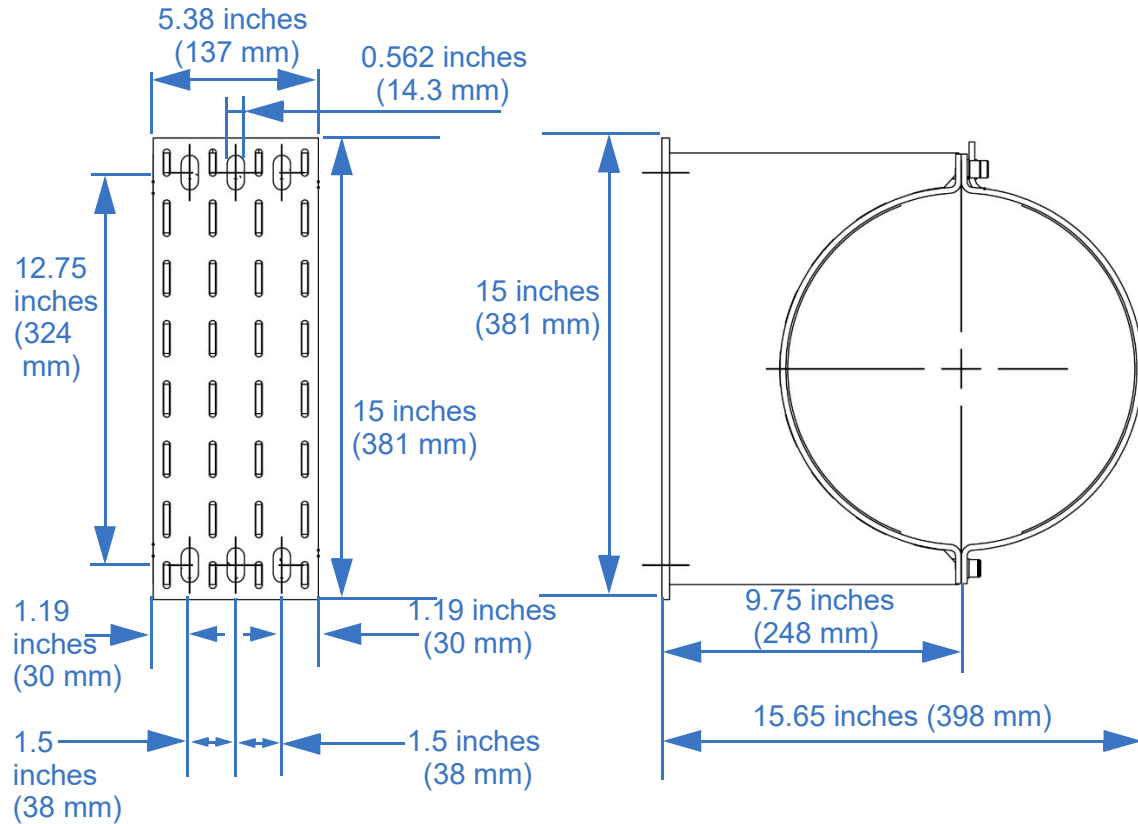

Figure 4-10 Support Bracket Assembly (Super Heavy Duty) Installation Specifications
(P/N: 4894901 Shown)

Note: Part Number 4894901 is for a black powder coat finish. Additional finishes are available.

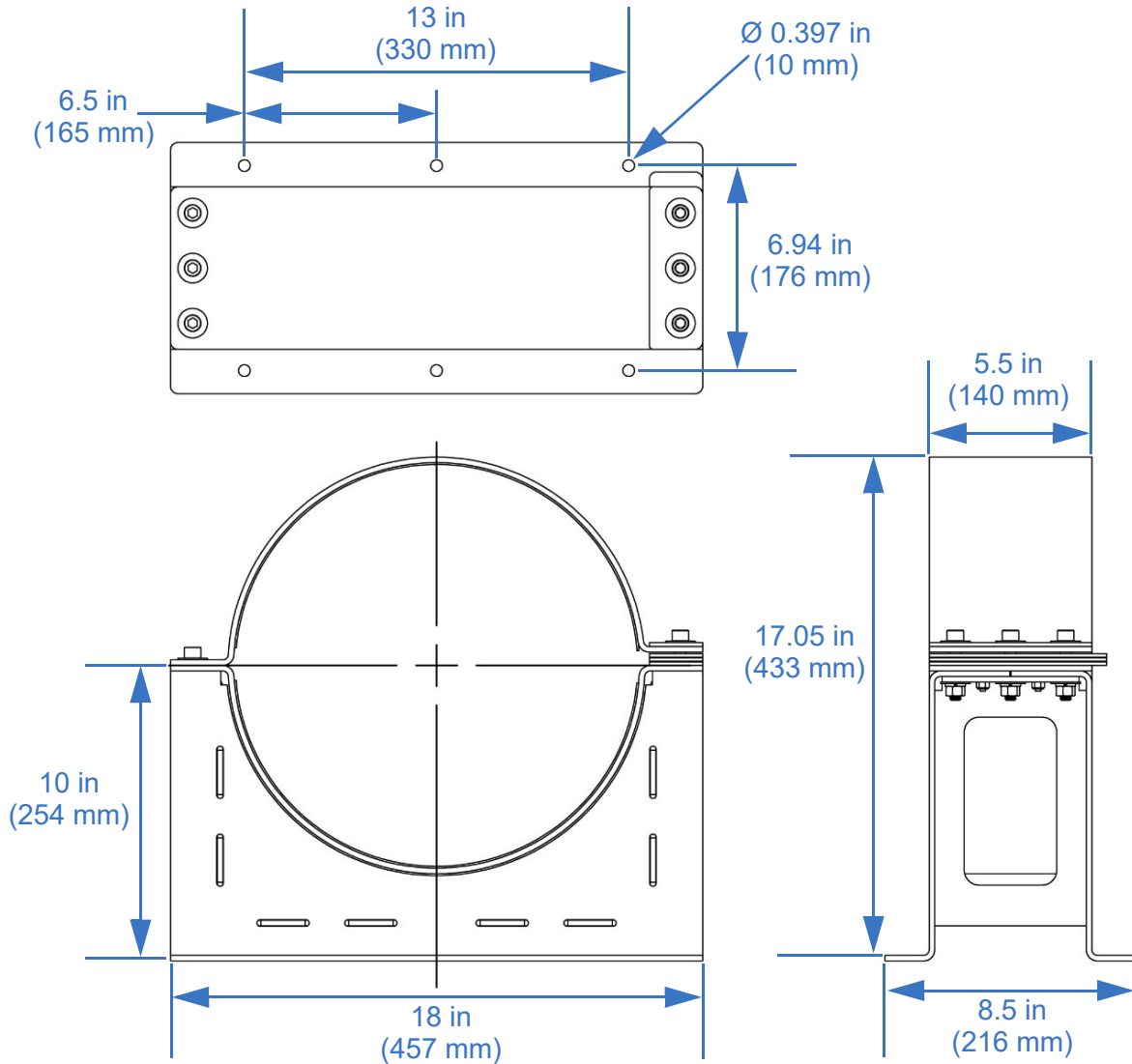

Figure 4-11 External Support Bracket Assembly (Ultra Heavy Duty) Installation Specifications (P/N: 4989201 Shown)

External support bracket P/N: 4989201 has a black powder coat finish. Additional finishes are available.

4.5.6 Internal Mounting Kit Installation Specifications

Table 4-12 Internal Mounting Kit (Roof Flange and Roof Ring) Installation Specifications

P/N*	Base Tube	Ø A		B	C		D		Ø BCD	
		inch	mm		inch	mm	inch	mm	inch	mm
905734	6 ¾	9 ¾	248	8	1.9	48.3	0.25	6.4	8 ¾	222
905733	9	12	305	8	1.9	48.3	0.25	6.4	11	279
910784	11 ¼	14.25	362	8	1.8	45.7	0.25	6.4	13	330
5476101	13.5	16.5	419	8	1.75	44.5	0.25	6.4	15 ¼	387

* Part Numbers for clear anodized finish. Additional finishes are available.

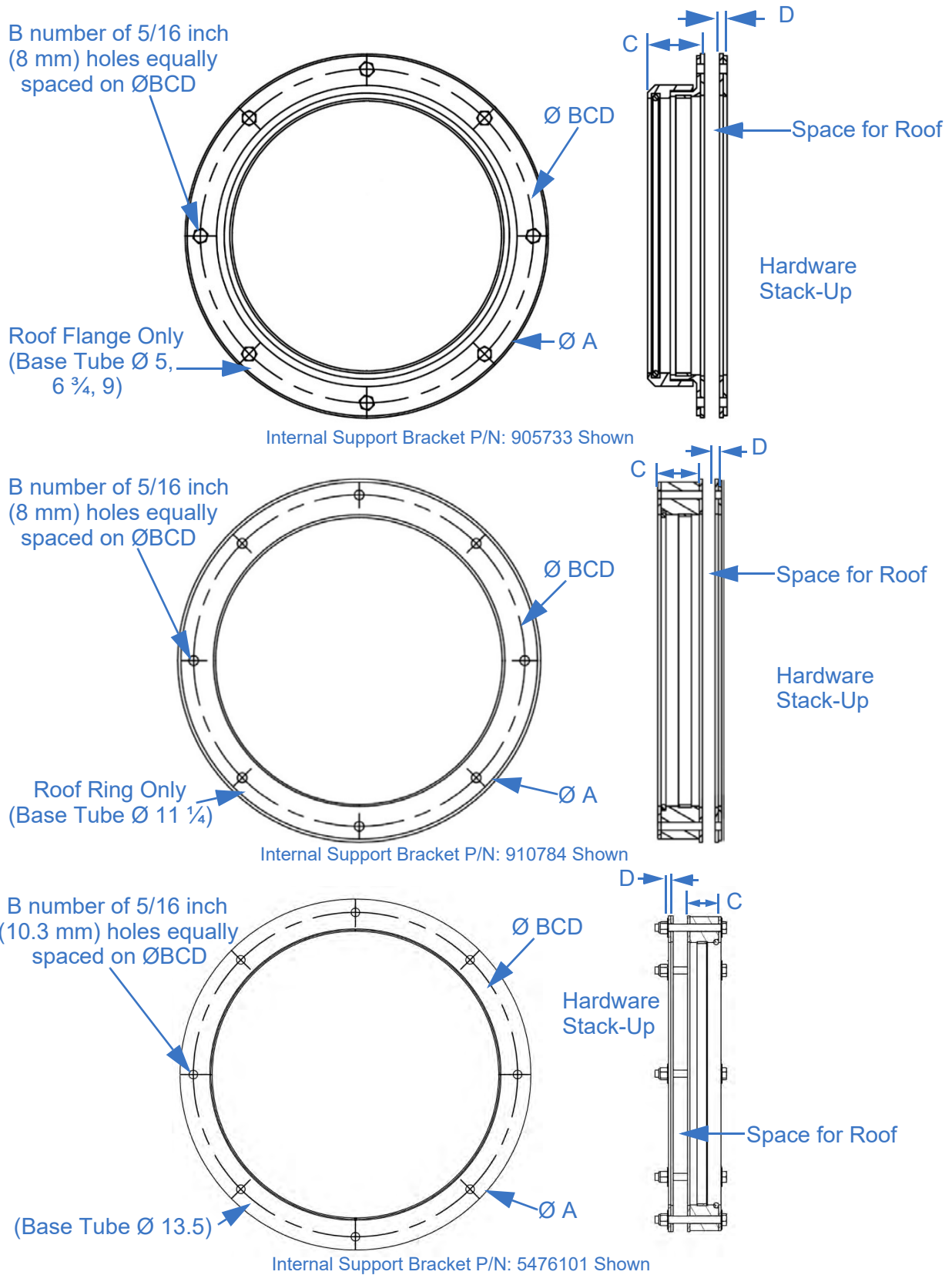

Figure 4-12 Internal Mounting Kit Hardware Installation Specifications

Figure 4-13 describes the dimensions for the Ultra Heavy Duty's internal mounting kit (P/N: 54761xx).

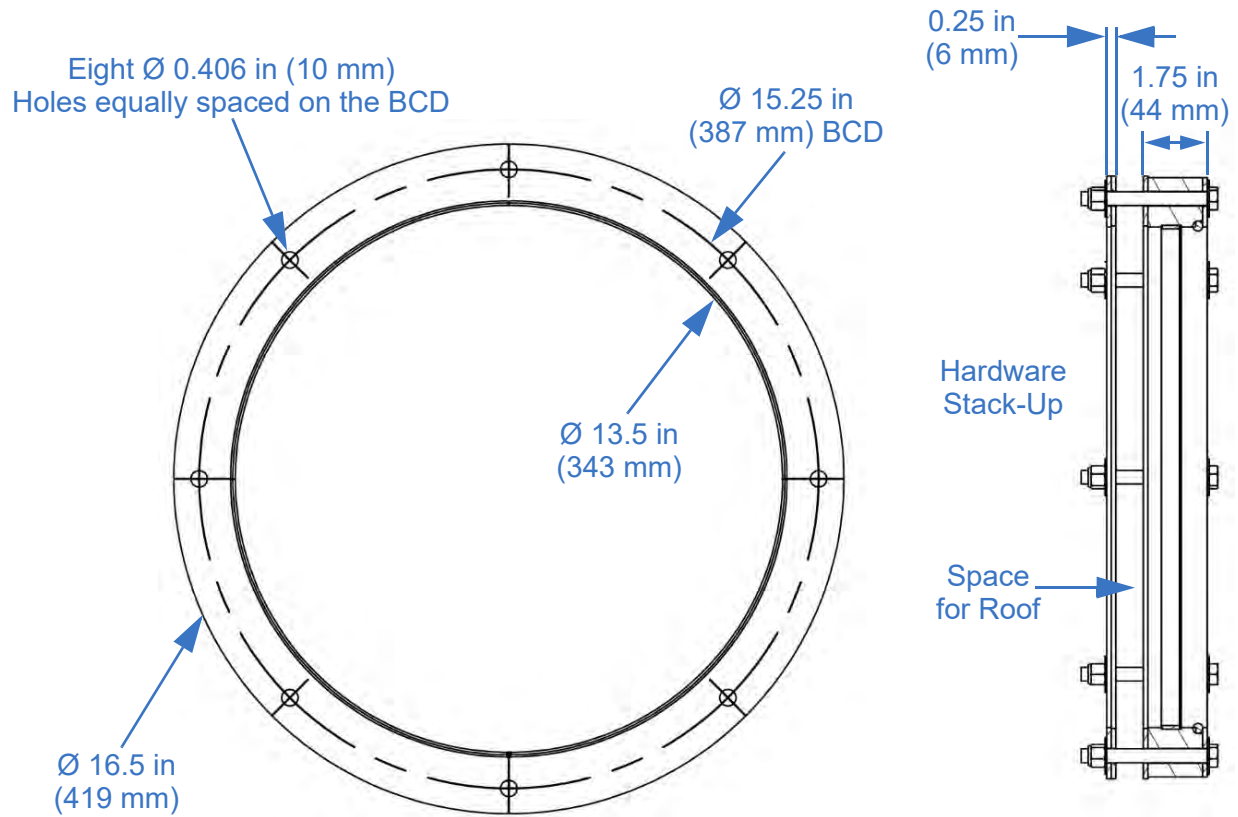

Figure 4-13 Internal Mounting Kit (Ultra Heavy Duty) Installation Specifications (P/N: 5476101 Shown)

4.5.7 Shelf Bracket Assembly Installation Specifications

Table 4-13 Shelf Bracket Assembly Specifications

P/N*	Base Tube	Base Plate**	A		B		C		D		E	
			inch	mm	inch	mm	inch	mm	inch	mm	inch	mm
4434101	6 ¾	NR	8.0	203	11.8	300	6.0	152	10.5	267	6.5	165
4454001		R	9.8	249	14.38	365	7.75	197	11.95	304	8.44	214
4454001	9	NR	9.8	249	14.38	365	7.75	197	11.95	304	8.44	214
4454101		R	10.0	254	15.88	403	8.0	203	14.5	368	10.75	273
913947	11 ¼	Both	12.0	305	20.25	514	8.0	203	14.5	368	10.24	260

P/N*	Base Tube	Base Plate**	F		G		H		J		K	
			inch	mm	inch	mm	inch	mm	inch	mm	inch	mm
4434101	6 ¾	NR	4.3	109	0.44	11	3.75	95	5.26	134	7.87	200
4454001		R	6.0	152	0.56	14	5.25	133	5.98	152	9.0	229
4454001	9	NR	6.0	152	0.56	14	5.25	133	5.98	152	9.0	229
4454101		R	6.3	160	0.56	14	3.75	95	7.3	185	9.75	248
913947	11 ¼	Both	6.0	152	0.56	14	4.0	102	7.19	183	13.75	349

P/N*	Base Tube	Base Plate**	L		M		N		P	
			inch	mm	inch	mm	inch	mm	inch	mm
4434101	6 ¾	NR	2.0	51	0.64	16	5.75	146	0.44	11
4454001		R	1.25	32	1.8	46	8.7	221	0.44	11
4454001	9	NR	1.6	41	0.63	16	8.0	203	0.44	11
4454101		R	1.38	35	0.62	16	11.0	279	0.44	11
913947	11 ¼	Both	1.38	35	1.0	25	11.0	279	0.56	14

* Part Numbers for 5, 6 ¾, and 9 inch Base Plates are for clear anodize finish. Part Number for 11 ¼ inch Base Plate is for black powder coat finish. Additional finishes are available.

** Non-Rotating (NR) and Rotating (R)

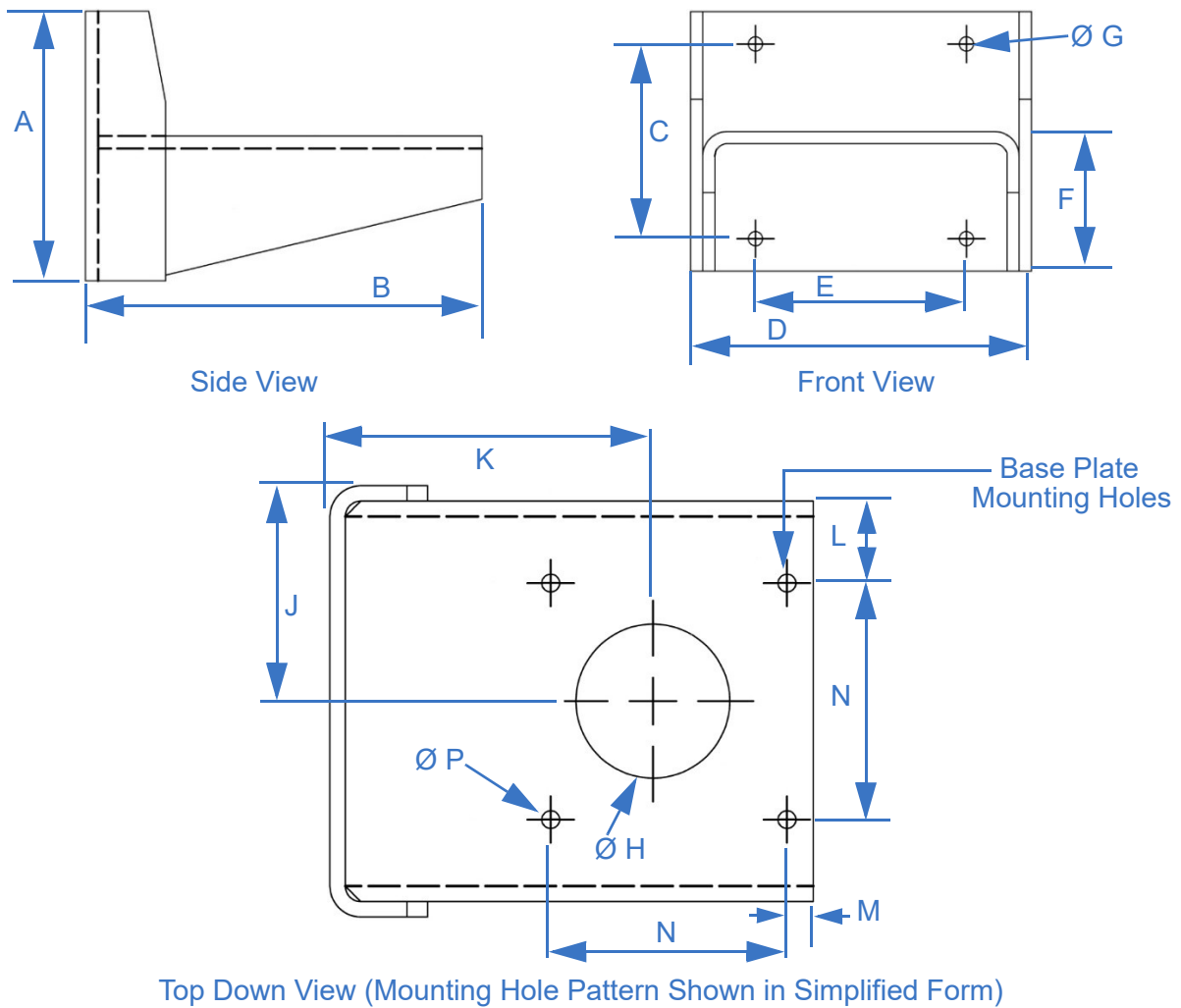

Figure 4-14 Shelf Bracket Installation Specifications

Note: For clarity purposes, the base plate mounting hole pattern shown (Figure 4-14) has been simplified. Actual shelf brackets may have multiple sets of base plate mounting holes in order to accommodate multiple mast types. Use the set of base plate mounting holes appropriate for your mast system.

4.5.8 Control Box Installation Specifications

The control box:

- Weighs approximately 11.8 lb.
- Has the dimensions shown in Figure 4-15.

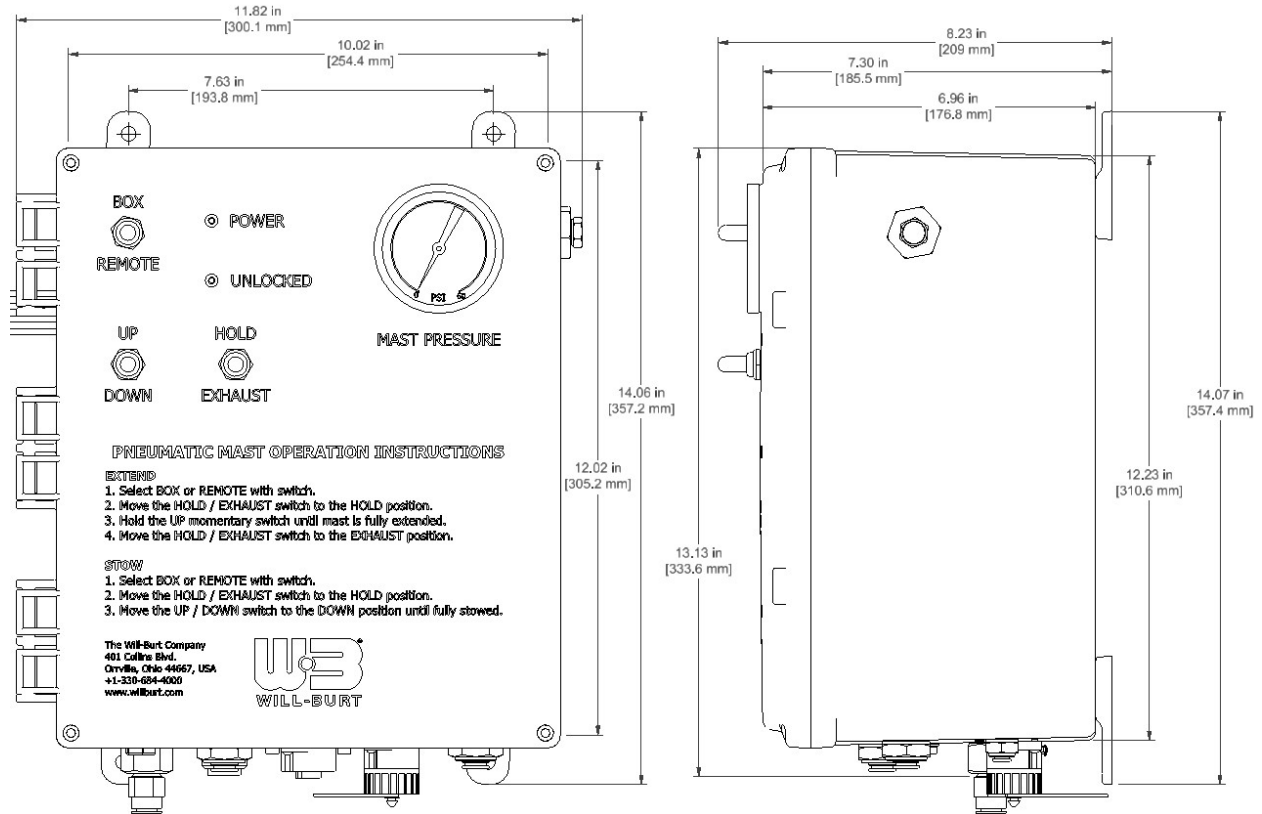

Figure 4-15 Control Box Installation Specifications (P/N: 5557301)

Note: The customer can reorient the control box feet 90° if desired.

5 Installation

This section describes the installation of the Pneumatic Mast with Remote Locking System and provides the general procedures that must be followed to ensure a successful installation. Be sure to read and understand the entire installation procedure and the Safety Summary in Section 1 before beginning installation. Use care to follow all precautions while installing.

For component installation dimensions and geometry, refer to Section 4.5.

5.1 Pre-Installation Check

Before installing the mast system, ensure:

- All installers read and understand the entire installation procedure.
- Only a properly trained and qualified certified electrician performs electric installations and maintenance.
- The mounting structure is level and has sufficient room and strength to mount the mast system (Section 4 and 5.6)
- All purchased components are included (Section 3.3).
- All required equipment is readily available (Section 5.2).
- When installing in a vehicle, that the vehicle is stationary and on a level surface.

Note: The Pneumatic Mast with Remote Locking System arrives with gaps on the locking pins between the Nyloc nut and the latch lever. Each gap is .100 in (2.54 mm). These gaps allow the pins to freely move as the mast deflects. These gaps should not be tightened in any situation. If the Nyloc nuts are tightened and the gaps are removed, the mast can prematurely retract.

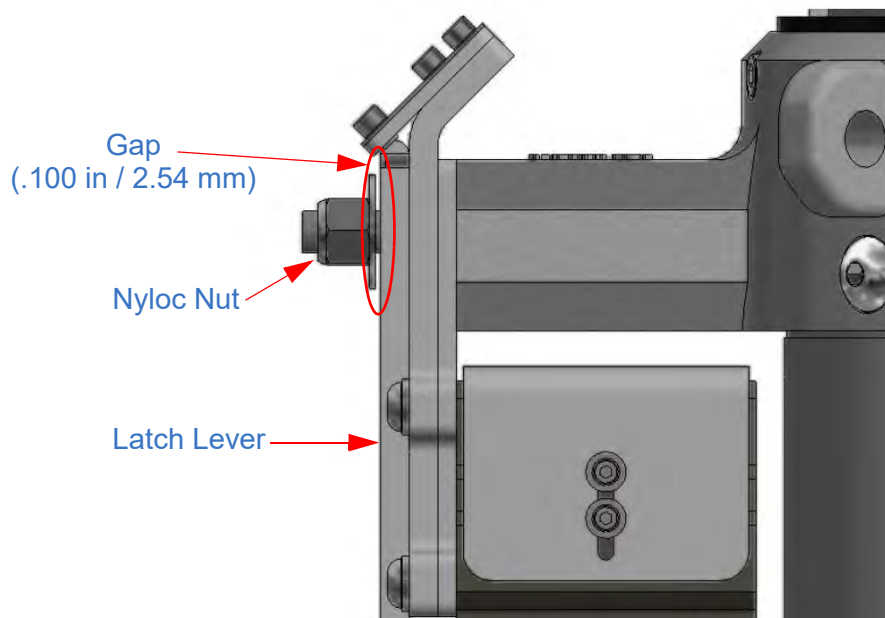

Figure 5-1 Gap Allows for Pins to Move Freely as the Mast Deflects

5.2 Installation Equipment

Table 5-1 lists general equipment recommended for installation. Depending on the mast system configuration, additional equipment may be required.

Table 5-1 Equipment Recommended for Installation

Recommended Equipment*		
Personal Protective		
Safety Glasses	Work Gloves	Safety Shoes
Hard Hat or Helmet	Hearing Protection	Nitrile or Vinyl Gloves
Hand Tools		
Wrenches	Screwdrivers	Hammer
Torque Wrench	Drill	Saw
Plumb-Bob	Measuring Tape	Level
Rubber Mallet	Rope or Thin Wire	Washers or Spacers (For shimming)
Sockets	Appropriate Hardware (Section 5.3)	16 AWG Stranded Wire (For the Magnetic Warning Kit)
Hex Wrenches		
Equipment		
Compressed Air Supply	Hoist	Sling / Strap
Expendables		
Pipe Thread Sealant or PTFE Tape	Rags (Clean and Dry)	Silicone Sealant
Loctite® 242/243 (Blue) or Equivalent	Soapy Water (When installing the weather bonnet)	
<p>*Note:</p> <ul style="list-style-type: none"> Depending on the local, regional, and national standards and codes of practice, and the environment, additional personal protective equipment may be necessary. Depending on the mast system configuration, additional equipment, including but not limited to, rubber washers or grommets (for the pneumatic system), electrical components (e.g. wire, fuses, circuit breakers, etc.), and air control valves, switches, air hose and fittings, may be required. When disposing of any disposables or components, do so according to any applicable local, regional, and national standards and codes of practice. 		

5.3 Installation Hardware

This section describes hardware that may be used during installation as follows:

- Table 5-2 Hardware for Internal Mount Application Installation
- Table 5-3 Hardware for External Mount Application Installation
- Table 5-4 Hardware for Ultra Heavy Duty Installation

Table 5-2 Hardware for Internal Mount Application Installation

Hardware*	Supplied By	Notes
Internal Mounting Kit (To the Roof)		
¼ Inch (M6) Bolts	Customer	Internal mounting kits for 6.75, 9.0, and 11.25 inch base tubes require eight sets of hardware. Internal mounting kits for 5.0 inch base tubes require six sets of hardware. The bolts should be sized to length to allow for the thickness of the internal mounting kit, lock washer, nut, roof, and any spacers.
¼ Inch (M6) Lock Washers	Customer	
¼ Inch (M6) Nuts	Customer	
Non-Rotatable Base Plate (To the Mast)		
(4) ⅜-16x1 Flathead Screws (P/N: 2772)	The Will-Burt Company	Found in the Hardware Bag
Non-Rotatable and Rotatable Base Plate (To the Mounting Surface)		
(4) ⅜-16x1-½ Inch Bolts (P/N: 901594)	The Will-Burt Company	Found in the Hardware Bag
(4) Flat Washers (P/N: 2054)	The Will-Burt Company	Found in the Hardware Bag
(4) Lock Washers (P/N: 0801)	The Will-Burt Company	Found in the Hardware Bag
(4) Nuts (P/N: 901593)	The Will-Burt Company	Found in the Hardware Bag

Table 5-2 Hardware for Internal Mount Application Installation (Continued)

Hardware*	Supplied By	Notes
Turning Handles (To Mast)		
(2) ¼-20x1.50 Hex HD Bolts (P/N: 2000)	The Will-Burt Company	Ships with Turning Handles
(2) ¼-20 Nyloc Nuts (P/N: 1930)	The Will-Burt Company	Ships with Turning Handles
Flashing Kit (Rotatable Super Heavy Duty Masts) (To the Mast)		
(6) ¼-20x0.75 Inch Bolts (P/N: 4542)	The Will-Burt Company	Ships with Flashing Kit
(12) ¼ Flat Washers (P/N: 0800)	The Will-Burt Company	Ships with Flashing Kit
(6) ¼ Nyloc Nuts (P/N: 1930)	The Will-Burt Company	Ships with Flashing Kit
Control Box (To the Mounting Structure)		
(4) ¼ (M6) Screws	Customer	The bolts should be sized to length to allow for the thickness of the control box feet, support structure, any spacers, and all mounting hardware (e.g. flat washers, lock washers, and nuts).
HHRC Holder (To the Mounting Structure)		
(2) #8 (M4) Flathead Screws	Customer	The bolts should be sized to length to allow for the thickness of the HHRC, support structure, any spacers, and all mounting hardware (e.g. flat washers, lock washers, and nuts).
* Unless otherwise indicated, the mounting hardware must include proper means to resist vibration loosening such as thread-locking compound or locking hardware. Torque all hardware as appropriate for its size and grade. Torque values in these instructions assume the use of The Will-Burt Company provided hardware. Depending on the specific installation application, all hardware may not be used. Additional hardware may be required for additional accessories, or customer-specific applications.		

Table 5-3 Hardware for External Mount Application Installation

Hardware*	Supplied By	Notes
Shelf Bracket (Optional) (To the Support Structure)		
(4) Bolts	Customer	Bolts should be sized to length to allow for the thickness of the shelf bracket, support structure, and any spacers and mounting hardware. Shelf bracket P/N: 4434101 uses 3/8 inch hardware. This shelf bracket is used for non-rotating and rotating masts with 5.0 inch base tubes and non-rotating masts with 6.75 inch base tubes. Shelf brackets P/N: 4454001, P/N: 4454101, and P/N: 913947 use 1/2 inch hardware. (Part Numbers for clear anodized finish only.)
(4) Flat Washers	Customer	
(4) Lock Washers	Customer	
(4) Nyloc Nuts	Customer	
Non-Rotatable Base Plate (To the Mast)		
(4) 3/8-16x1 Flathead Screws (P/N: 2772)	The Will-Burt Company	Found in the Hardware Bag
External Support Bracket (P/N: 4443601) (To the Support Structure)		
(6) Sets of 3/8 Inch Hardware	Customer	The bolts should be sized to length to allow for the thickness of the external support bracket, support structure, any spacers, and all mounting hardware (e.g. flat washers, lock washers, and nuts).
External Support Bracket (P/N: 909984 and P/N: 4894901) (To Support Structure)		
(6) Sets of 1/2 Inch Hardware	Customer	The bolts should be sized to length to allow for the thickness of the external support bracket, support structure, any spacers, and all mounting hardware (e.g. flat washers, lock washers, and nuts).

Table 5-3 Hardware for External Mount Application Installation (Continued)

Hardware*	Supplied By	Notes
Non-Rotatable and Rotatable Base Plate (To the Mounting Surface)		
(4) 3/8-16x1-1/2 Inch Bolts (P/N: 901594)	The Will-Burt Company	Found in the Hardware Bag
(4) Flat Washers (P/N: 2054)	The Will-Burt Company	Found in the Hardware Bag
(4) Lock Washers (P/N: 0801)	The Will-Burt Company	Found in the Hardware Bag
(4) Nuts (P/N: 901593)	The Will-Burt Company	Found in the Hardware Bag
Turning Handles (To Mast)		
(2) 1/4-20x1.50 Hex HD Bolts (P/N: 2000)	The Will-Burt Company	Ships with Turning Handles
(2) 1/4-20 Nyloc Nuts (P/N: 1930)	The Will-Burt Company	Ships with Turning Handles
Control Box (To the Mounting Structure)		
(4) 1/4 (M6) Screws	Customer	The bolts should be sized to length to allow for the thickness of the control box feet, support structure, any spacers, and all mounting hardware (e.g. flat washers, lock washers, and nuts).
HHRC Holder (To the Mounting Structure)		
(2) #8 (M4) Flathead Screws	Customer	The bolts should be sized to length to allow for the thickness of the HHRC, support structure, any spacers, and all mounting hardware (e.g. flat washers, lock washers, and nuts).
* Unless otherwise indicated, the mounting hardware must include proper means to resist vibration loosening such as thread-locking compound or locking hardware. Torque all hardware as appropriate for its size and grade. Torque values in these instructions assume the use of The Will-Burt Company provided hardware. Depending on the specific installation application, all hardware may not be used. Additional hardware may be required for additional accessories, or customer-specific applications.		

Table 5-4 Hardware for Ultra Heavy Duty Installation

Hardware*	Supplied By	Notes
Non-Rotatable Base Plate (To the Mast)		
(4) ½-13x1.25 Flathead Screws (P/N: 5402)	The Will-Burt Company	Found in the Hardware Bag
External Support Bracket (To the Support Structure)		
(6) Sets of ¾ Inch Hardware	Customer	The bolts should be sized to length to allow for the thickness of the external support bracket, support structure, any spacers, and all mounting hardware (e.g. flat washers, lock washers, and nuts).
Internal Mounting Kit (To the Roof) (Used in place of the External Support Bracket)		
(8) ¾-16x3.50 Bolts (P/N: 5431)	The Will-Burt Company	Included with internal mounting kit. Included hardware is sized for a ¼ inch (6.35 mm) roof. If a thicker roof is present, the customer must supply appropriate hardware.
(16) ¾x1.0 Flat Washers (P/N: 2054)	The Will-Burt Company	
(8) ¾-16 Nyloc Nuts (P/N: 2763)	The Will-Burt Company	
Non-Rotatable Base Plate (To the Mounting Surface)		
(6) ¾-16x1-½ Inch Bolts (P/N: 901594)	The Will-Burt Company	Found in the Hardware Bag
(6) Flat Washers (P/N: 2054)	The Will-Burt Company	Found in the Hardware Bag
(6) Lock Washers (P/N: 0801)	The Will-Burt Company	Found in the Hardware Bag
(6) Nuts (P/N: 901593)	The Will-Burt Company	Found in the Hardware Bag
Control Box (To the Mounting Structure)		
(4) ¼ (M6) Screws	Customer	The bolts should be sized to length to allow for the thickness of the control box feet, support structure, any spacers, and all mounting hardware (e.g. flat washers, lock washers, and nuts).

Table 5-4 (Continued) Hardware for Ultra Heavy Duty Installation

Hardware*	Supplied By	Notes
HHRC Holder (To the Mounting Structure)		
(2) #8 (M4) Flathead Screws	Customer	The bolts should be sized to length to allow for the thickness of the HHRC, support structure, any spacers, and all mounting hardware (e.g. flat washers, lock washers, and nuts).
<p>* Unless otherwise indicated, the mounting hardware must include proper means to resist vibration loosening such as thread-locking compound or locking hardware. Torque all hardware as appropriate for its size and grade. Torque values in these instructions assume the use of the The Will-Burt Company provided hardware. Depending on the specific installation application, all hardware may not be used. Additional hardware may be required for additional accessories or customer-specific applications.</p>		

5.4 Lift the Mast System

During installation, it will be necessary to lift the mast. The process described in this manual represents a possible method of lifting the mast. Depending on the environment and equipment available, other methods may work better. Use the best and safest method for your circumstances.

5.5 Unpack the Mast System

Unpack the system as follows:

1. Carefully open the shipping crate.
2. Remove all loose components, the 2 x 4 inch (38 x 89 mm) block at the top end of the mast, and the top half of the wooden mast saddles (Figure 5-2).

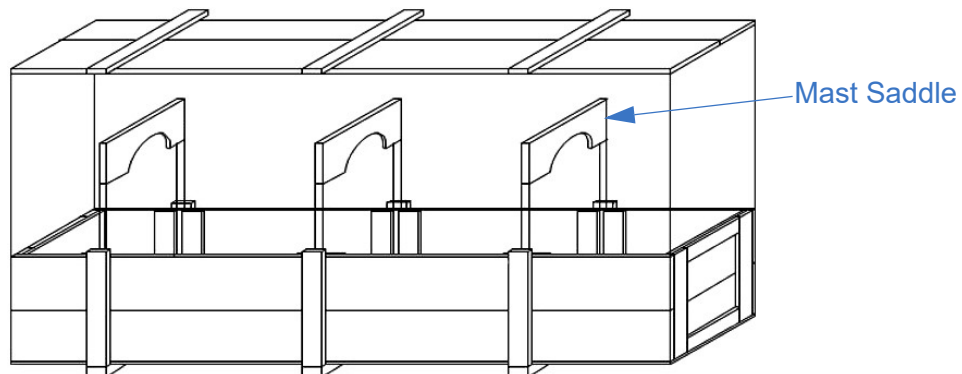

Figure 5-2 Shipping Crate

3. Ensure all components are included and that the required tools are readily available. The components in the system shipment are shown in Table 5-5. The components your system includes will vary based upon your order.

Table 5-5 Possible Components in the System Ship

Telescoping Mast	Hardware Bag (P/N: 5032501 or 902853)	Drain Kit (P/N: 902982)	Magnet Warning Kit
Mast Top Cover (P/N: 5063501 or 902989)	Identification Plate (P/N: 902851)	Label Kit (English)	Control System (P/N: 5572601)
Pneumatic System Options (Sold Separately)	Base Plate Options: <ul style="list-style-type: none"> • Non-Rotatable Base Plates • Rotatable Base Plates 	Payload Platforms and Stub Adaptors (Sold Separately)	Support Bracket Options: <ul style="list-style-type: none"> • Internal (Roof) Mounting Kit • External Support Bracket
Shelf Bracket	Guy Line Options (Sold Separately)	Additional Accessory Options (Sold Separately)	Hold Down Leash
Operating Manual (this manual)			

4. Inspect for any shipping damage. Notify the carrier if damage is evident.
5. Using the center of gravity (COG) label as a reference, outfit the mast with a sling capable of supporting the mast weight (Figure 5-3). The sling must support the mast from at least two points. Attach the sling so that horizontal balance and control can be maintained while positioning the mast. Hoist and slowly lift the mast until just free of the mast saddles. Lower the mast and adjust the sling as necessary to balance the mast. Hoist the mast free from the crate and carefully move the mast into the desired position.

Note: Do NOT apply pressure to the air cylinders when lifting. Lifting with weight on the air cylinders could damage the mast.

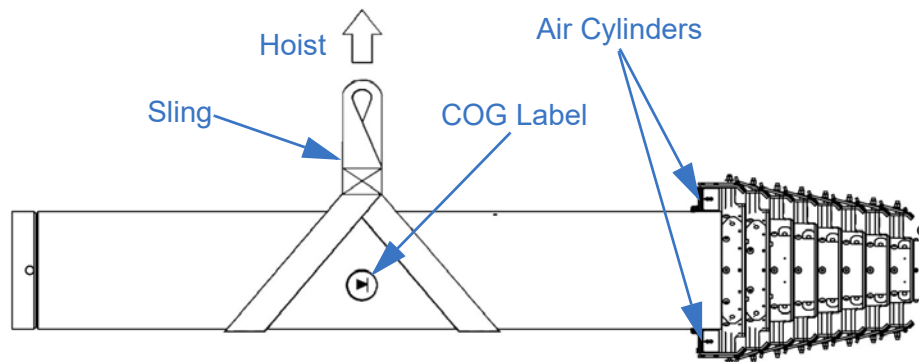

Figure 5-3 Hoist the Mast

The Will-Burt Company recommends keeping the shipping crate for transporting the mast, for example if shipping the mast back to the factory for refurbishment.

5.6 Mast Installation External Mount

This section describes installation of an externally mounted mast (Figure 5-4). The external mounting instructions assume the use of an external support bracket. For information on mounting the mast internally, see Section 5.7.

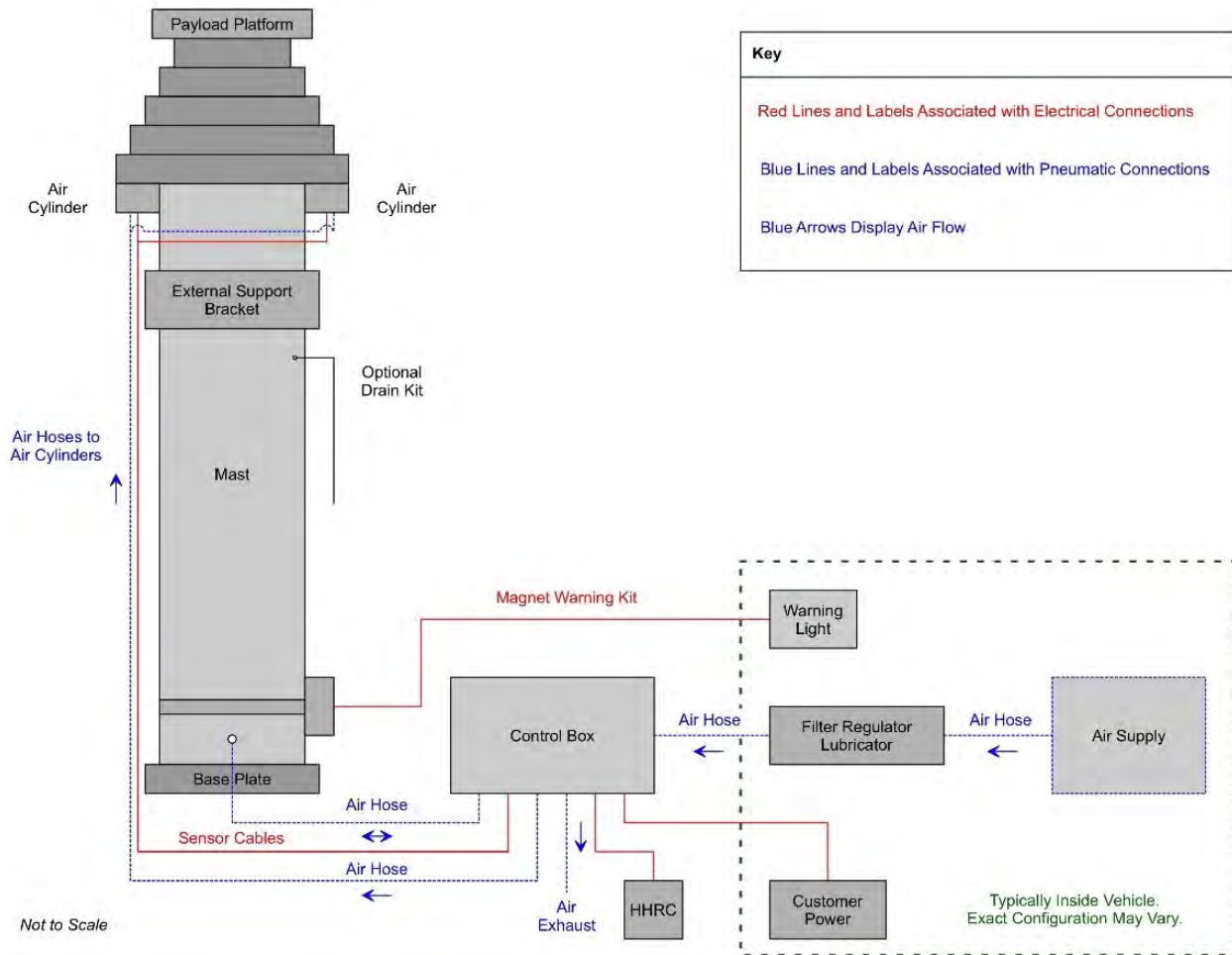

Figure 5-4 Typical External Mount Application (Not to Scale)

5.6.1 External Mount Quick Summary

The following is a quick summary of installation of an externally mounted mast. Detailed steps follow the quick summary (Section 5.6.2).

Install an externally mounted mast as follows:

1. Select a Suitable Mounting Location (Section 5.6.2.1)
2. Install the Shelf Bracket (Optional) (Section 5.6.2.2)
3. Attach the Base Plate to the Mast (Section 5.6.2.3)
4. Position the Mast (Section 5.6.2.4)
5. Install the External Support Bracket (Section 5.6.2.5)
6. Secure the Base Plate to the Mounting Surface (Section 5.6.2.6)
7. Install the Control and Pneumatic Systems (Section 5.8)
8. Install the Drain Kit (Optional for External Mount Applications) (Section 5.9)
9. Install the Magnetic Warning Kit (Vehicle Mount Applications) (Section 5.10)

5.6.2 External Mount Detailed Instructions

The following are detailed steps of the installation of an externally mounted mast. The exact installation procedures may vary based on the configuration of the mast system being used and the installation environment.

5.6.2.1 Select a Suitable Mounting Location

When selecting a suitable mounting location, consider the following:

- The mounting area must have sufficient room to mount the mast system. It is recommended that the external support bracket be positioned at least 1 inch (25 mm) below the RLS Guard, but no lower than 12 inches (304 mm) below the RLS Guard. This measurement goes from the bottom of the RLS Guard to the top of the external support bracket. Lowering the external support bracket any further may impact the wind performance. Consult the factory. Do not cover the drain hole. The exact dimensions of the mast system will vary based on the components included. Refer to Section 5.6 for dimension information.
- The mounting structure must be level, solid, and capable of holding the forces required by the bolts. Check the strength and rigidity of the mounting structure (e.g. vehicle body) where the mast system is to be attached. Reinforce as necessary.
 - Note: High forces to the mounting structure may result, depending on the payload, wind load, and if the mast is guyed or not. The mounting surface to which the base plate is secured will also see high downward forces and moments. For example, a typical unguyed mast can cause a 500 ft.-lb. (677.9 N m) torque, whereas a typical guyed mast can produce 3,500 lb. (1587.6 kg) of downward force onto the base plate. The Will-Burt Company's engineering should be consulted for specific payload and mounting requirements for your mast application.
- The area underneath the mast must be free of obstructions to allow for accessibility to base plate fasteners and if present and used, the bottom air inlet port.
- The mounting location must have sufficient access for the pneumatic system.
- For mounting applications using a rotatable base plate, ensure the location of the mast allows enough clearance to accommodate the turning handles and the air hose if the air is routed to a side air inlet port. Rotatable Super Heavy Duty masts do not use turning handles but will need clearance for a customer-supplied rod to be inserted into the tube head to turn the mast.
- As mast tubes extend, they force water out of the weep holes. Keep any personnel or sensitive equipment away from the weep hole direction.
- If the mast system is mounted in a well, provide adequate drainage. A minimum of four 1 inch (25.4 mm) drain holes (one per corner) are recommended.

5.6.2.2 Install the Shelf Bracket (Optional)

To install a shelf bracket (if used):

1. Position the shelf bracket ensuring the shelf bracket is level.
2. Use the shelf bracket as a template to drill holes through the support structure.
3. If necessary, use washers or short spacers made of ¼ inch (6.35 mm) pipe to level out any irregularities that exist in the support structure.
4. Secure the shelf bracket to the support structure using:
 - (4) Bolts
 - (4) Flat Washers
 - (4) Lock Washers
 - (4) Nyloc Nuts

See Section 5.3 for hardware sizing. Ensure the shelf bracket is level in all directions. The mounting hardware must include proper means to resist vibration loosening such as thread-locking compound or locking hardware. Torque all hardware as appropriate for its size and grade

5.6.2.3 Attach the Base Plate to the Mast

This section describes installing the mast and base plate. The exact procedures vary depending on whether the mast system uses a non-rotatable or rotatable base plate. Follow the appropriate installation instructions for your mast system.

Non-Rotatable Base Plates

To install a non-rotatable base plate:

1. If necessary, use a hoist to lift the mast so the bottom of the mast can be accessed.
2. Position the base plate against the base of the mast so the mounting holes align. Ensure the countersunk holes are facing away from the mast.
3. Heavy Duty and Super Heavy Duty: Secure the base plate to the mast with the (4) $\frac{3}{8}$ -16x1 flathead screws (P/N: 2772) from the hardware bag. Apply Loctite[®] 242/243 (Blue) or equivalent. Torque to 15.83-20 ft.-lb. (21-27 Nm).

Ultra Heavy Duty: Secure the base plate to the mast with the (4) $\frac{1}{2}$ -13x1.25 flathead screws (P/N: 5402) from the hardware bag. Apply Loctite[®] 242/243 (Blue) or equivalent. Torque to 37.5-43.33 ft.-lb. (51-59 Nm).

Rotatable Base Plates

To install a rotatable base plate:

1. If necessary, use a hoist to lift the mast so the bottom of the mast can be accessed.
2. Back the locking screws far enough out of the base plate to allow the base plate to fit over the end of the mast.
3. Slide the base plate over end of the mast.
4. Tighten down the locking screws to secure the base plate to the mast.

5.6.2.4 Position the Mast

To position the mast:

1. Carefully move the mast into the desired mounting location.
2. Lower the mast the rest of the way to the mounting surface.
3. Carefully move the mast into position ensuring the mast is level. It is necessary to check the mast in two places 90° apart when leveling. Be certain to orient the mast so the operator has a clear view of the hazard labels.

Note: Additional labels are provided with the operator's manual and should be applied where the operator will have a clear view of them while operating the masts.

5.6.2.5 Install the External Support Bracket

This section describes installation of the external support bracket for the Heavy Duty and Super Heavy Duty masts. For information on how to install the external support bracket for the Ultra Heavy Duty masts, skip ahead a few pages and find the section that says "Ultra Heavy Duty: Install the External Support Bracket".

To install the external support bracket:

1. Determine the desired location for the external support bracket. The external support bracket must be at least 1 inch (25 mm) above the drain hole and at least 1 inch (25 mm) below the base tube collar. Do not cover the drain hole. The exact dimensions of the mast system will vary based on the components included. Refer to Section 4.5.5 for dimension information.

2. Secure the external support bracket around the base tube with the hardware from the external support bracket kit. Do not overtighten the external support bracket and deform the base tube (doing this damages the mast). The mounting hardware must include proper means to resist vibration loosening, such as thread-locking compound or locking hardware. Torque all hardware as appropriate for its size and grade.

For external support bracket:

- P/N: 4443601: Torque the 3/8-16 bolts to 15.83-20 ft.-lb. (21-27 Nm)
- P/N: 909984: Torque the 3/8-16 bolts to 15.83-20 ft.-lb. (21-27 Nm)
- P/N: 4894901: Torque the first five 3/8-16 bolts to 16.7 ft.-lb. (22 Nm) and final 3/8-16 bolt to 20 in.-lb. (2.2 Nm) (Figure 5-5). Only torque the final 3/8-16 bolt after torquing the first five bolts.

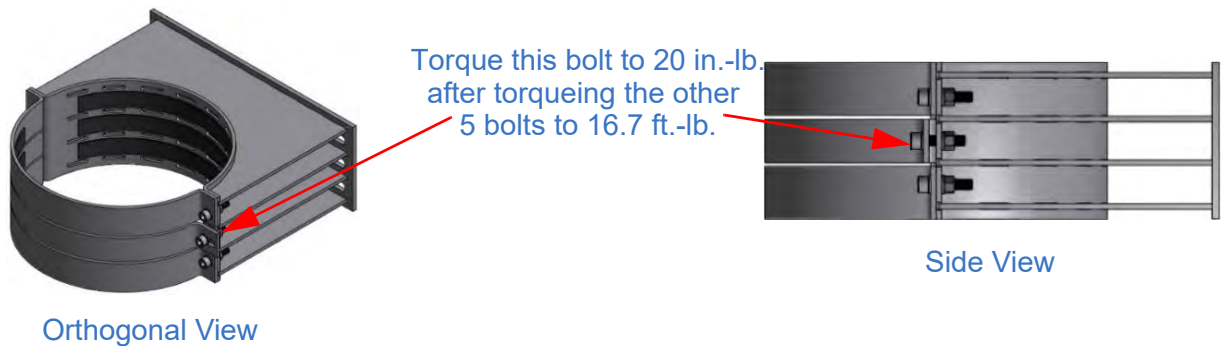

Figure 5-5 External Support Bracket P/N: 4894901 Installation

3. If necessary, use the external support bracket as a template to drill holes in the desired support structure. Ensure the mast system is level in all directions during drilling.
4. Ensure the mast system is level in all directions. If necessary, spacers may be added between the external support bracket and the support structure to keep the correct alignment between the external support bracket and the support structure.
5. Secure the external support bracket to the support structure with:
 - a. (6) Sets of 7/16 Hardware for External Support Bracket P/N: 4443601
 - b. (6) Sets of 9/16 Hardware for External Support Brackets P/N: 909984 and P/N: 4894901

See Section 5.3 for hardware sizing. The mounting hardware must include a proper means to resist vibration loosening such as thread-locking compound or locking hardware. Torque all hardware as appropriate for its size and grade.

Ultra Heavy Duty: Install the External Support Bracket

This section describes installation of the external support bracket. To allow for slight variation between mast tubes, the external support bracket has been designed to allow for adjustment of the tightness of the support bracket clamp. When properly installed, the external support bracket should snugly secure the mast without bending the external support bracket or mast. To adjust the external support bracket, anywhere from zero to three shims may be installed between the support bracket weldment and support bracket clamp. Any shims not used, will be stored between the support bracket clamp and the washer plate. The washer plate is installed between the support bracket clamp and the hardware on the left (shimming) side of the external support bracket and is used to distribute the forces generated over the support bracket clamp flange.

To secure the mast in the external support bracket:

1. Determine the desired location for the external support bracket. The external support bracket must be at least 1 inch (25 mm) above the drain hole and at least 1 inch (25 mm) below the RLS Guard. Do not cover the drain hole. The exact dimensions of the mast system will vary based on the components included. Refer to Section 5.6 for dimension information.
2. Remove the support bracket clamp. Set the hardware from the right side of the external support bracket to the right, and the hardware from the left side of the external support bracket to the left. Note that the screws on the left (shim) side of the external support bracket are longer than the screws on the right side.
3. As you face the mast and the support structure, position the external support bracket around the base tube so that the shims will be on the left side of the mast. Ensure the mast is properly oriented to allow for access to the drain cock, air inlet port, and locking mechanisms. Once the external support bracket is clamped down, it will not be possible to rotate the mast.

4. Secure the external support bracket around the base tube as follows:
 - a. Secure the mast temporarily in position to prevent it from leaning or falling throughout installation of the support bracket clamp. Ensure the mast is level and snug against the back of the external support bracket. If the mast is not snug against the external support bracket, the support bracket clamp may not be adjusted properly. It is necessary to check the mast in two places 90° apart when leveling.
 - b. Secure the right side of the support bracket clamp to the support bracket weldment with the hardware from the right side (Figure 5-6). Align from outside in as follows:

- i. $\frac{3}{8}$ -16 x1 .50 Cap Screw

- ii. Flat Washer

- iii. Support Bracket Clamp

- iv. Support Bracket Weldment

- v. Flat Washer (Hidden)

- vi. Lock Washer (Hidden)

- vii. Hex Nut

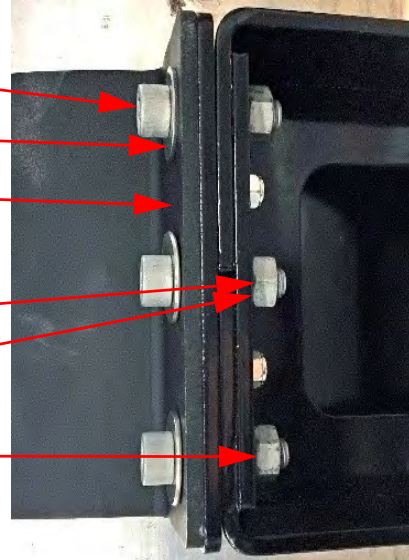

Torque hardware to 15.83-20 ft.-lb. (21-27 N m).

Figure 5-6 Hardware Right Side

- c. On the left side of the external support bracket, align the hardware from outside in as follows (Figure 5-7):
 - i. $\frac{3}{8}$ -16 x 2.00 Cap Screw
 - ii. Flat Washer
 - iii. Washer Plate
 - iv. Support Bracket Clamp
 - v. Support Bracket Weldment

- d. The washer plate should be aligned so that its outside edge is flush with the outside edge of the support bracket clamp (Figure 5-7). If the outside edge sticks out beyond the edge of the support bracket clamp (Figure 5-7), it is installed backwards and needs flipped.

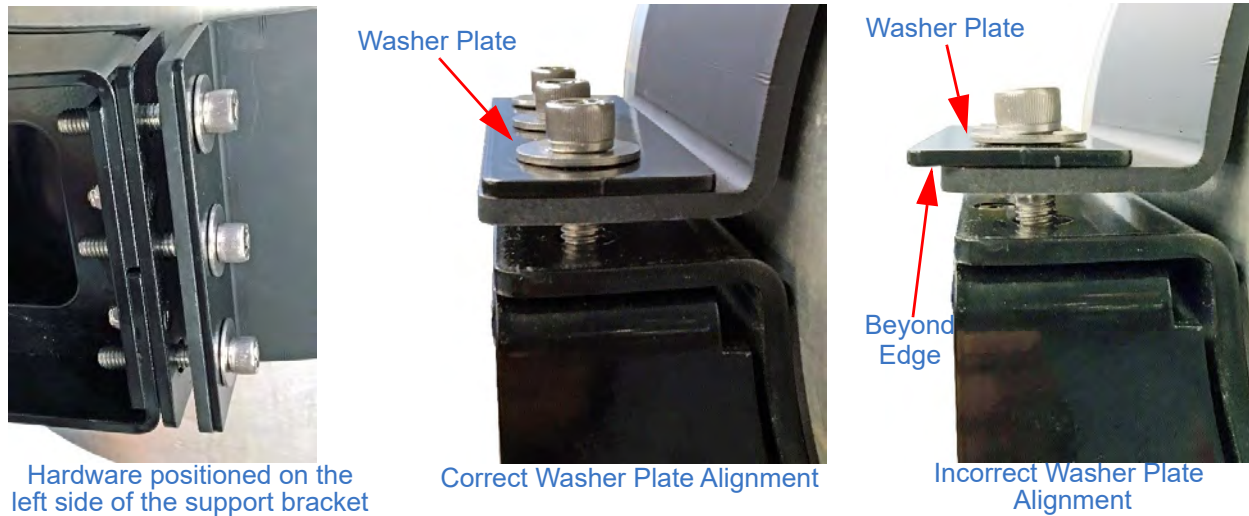

Figure 5-7 Hardware Positioning and Alignment

- e. Press with your hand against the left support bracket clamp flange and push it towards the support bracket weldment (Figure 5-8). Looking at the gap between the support bracket weldment and the support bracket clamp, estimate how many of the shims can fit in the gap while allowing the external support bracket to snugly secured to the mast, but without bending the support bracket clamp.

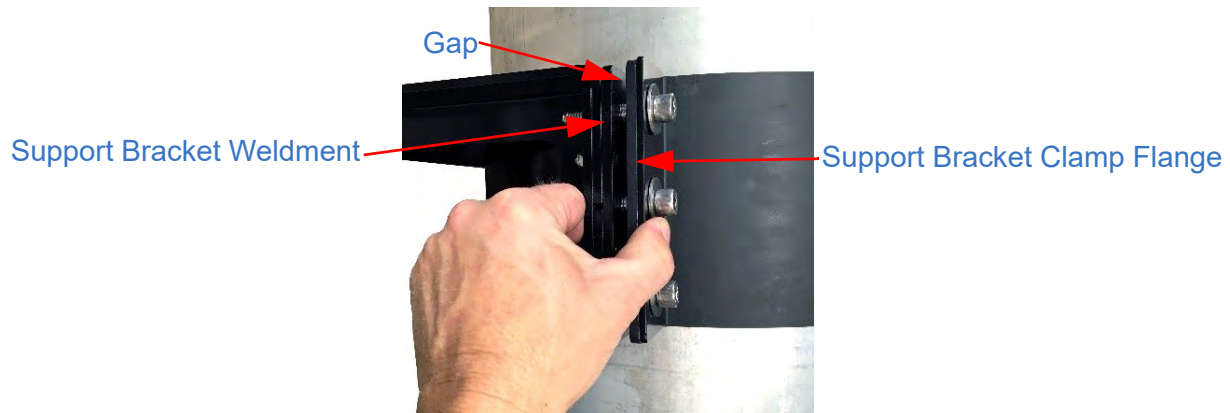

Figure 5-8 Press the Support Bracket Clamp Flange Towards the Bracket Weldment

- f. Release the support bracket clamp and insert the estimated number of shims between the support bracket clamp and the support bracket weldment (Figure 5-9). Do not pull out on the support bracket clamp. If a shim does not easily fit between the support bracket clamp and support bracket weldment, that shim is not necessary, and should not be used. Any unused shims should be inserted between the support bracket clamp and the washer plate. The shims should be inserted so that the bottom of the shims hangs down below the bottom of the support bracket clamp.

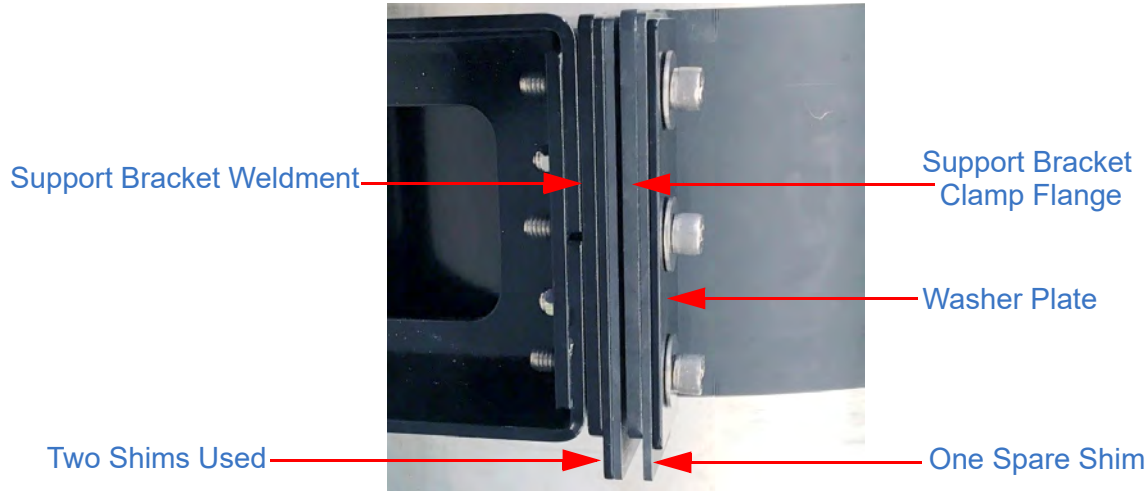

Figure 5-9 Shims Inserted (Shown with Two Shims Used and One Spare)

- g. Loosely secure the left side of the support bracket clamp to the support bracket weldment with the remaining hardware. Align from outside in as follows:

i. $\frac{3}{8}$ -16 x 2.00 Cap Screw

ii. Flat Washer

iii. Washer Plate

iv. Support Bracket Clamp

v. Support Bracket Weldment

vi. Flat Washer (Hidden)

vii. Lock Washer (Hidden)

viii. Hex Nut

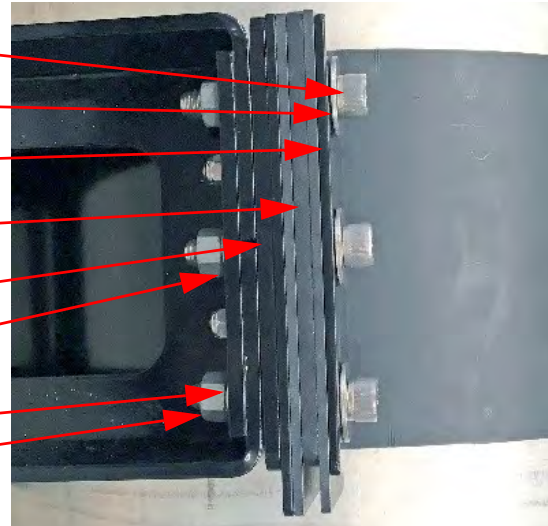

Figure 5-10 Hardware Left Side

- h. Tighten the left side. Ensure the external support bracket snugly secures the mast without bending the support bracket clamp. If necessary, adjust the shims. Torque to 15.83-20 ft.-lb. (21-27 Nm).

Note: If it is necessary to adjust the shims, they can be removed without completely loosening the hardware. To adjust the location of a shim:

- i. Push up on the shim from the bottom until the bottom of the grooves in the shim touch the bolts (Figure 5-11).



Figure 5-11 Push Up Shim

- ii. Pull out the shim (Figure 5-12).



Figure 5-12 Remove Shim

- iii. Relocate and insert the shim to its new position.
 - iv. Push the shim down into position.
 - i. Torque all hardware as appropriate for its material and size.
5. If necessary, use the external support bracket as a template to drill holes in the desired support structure. Ensure the mast system is level in all directions during drilling.

6. Ensure the mast system is level in all directions. If necessary, spacers may be added between the external support bracket and the support structure to keep the correct alignment between the external support bracket and the support structure.
7. Secure the external support bracket to the support structure with (6) sets of $\frac{3}{8}$ inch hardware. The bolts should be sized to length to allow for the thickness of the external support bracket, support structure, any spaces, and all mounting hardware (e.g. flat washers, lock washers, and nuts). The mounting hardware must include a proper means to resist vibration loosening such as thread-locking compound or locking hardware. Torque all hardware as appropriate for its size and grade.

5.6.2.6 Secure the Base Plate to the Mounting Surface

To secure the base plate to the mounting surface:

1. If necessary, use the base plate as a template to drill holes through the mounting surface.
2. Ensure the base plate and mast are level in all directions. It is necessary to check the mast in two places 90° apart when leveling.
3. Secure the base plate to the mounting surface with appropriate hardware. To secure the base plate, the hardware bag contains:
 - a. (4) $\frac{3}{8}$ -16x1- $\frac{1}{2}$ inch Bolts (P/N: 901594)
 - b. (4) Flat Washers (P/N: 2054)
 - c. (4) Lock Washers (P/N: 0801)
 - d. (4) Nuts (P/N: 901593)

Note: Ultra Heavy Duty masts contain (6) units of hardware instead of (4) units.

Depending on the customer-specific mounting application, other (customer-supplied) hardware may be required. The mounting hardware must include proper means to resist vibration loosening such as thread-locking compound or locking hardware. Torque to 15.83-20 ft.-lb. (21-27 Nm).

Once the mast is installed, see Section 5.8 for information on installing the pneumatic system.

5.6.2.7 Install the Turning Handles (Rotatable Mast Systems Only)

Rotatable base plate kits for Heavy Duty masts ship with turning handles to assist in rotating the mast. Super Heavy Duty and Ultra Heavy Duty masts do not use turning handles.

To secure the turning handles:

1. Determine the desired location for the turning handles. If feasible, The Will-Burt Company recommends installing above the drain hole. Do not cover drain hole with the turning handles.
2. Secure the band clamp halves together around the mast with:
 - (2) ¼-20x1.50 Hex HD Bolts (P/N: 2000)
 - (2) ¼-20 Nyloc Nuts (P/N: 1930)

Tighten the turning handle bolts just enough to allow the turning handles to turn the mast without slipping. Overtightening the turning handle bolts can deform the base tube and impede the movement of the next internal section.

For masts with:

- Ø 5.00 Inch Base Tube: Torque to 60 in.-lb. (6.8 Nm) Maximum
- Ø 6.75 Inch Base Tube: Torque to 100 in.-lb. (11.3 Nm) Maximum
- Ø 9.00 Inch Base Tube: Torque to 120 in.-lb. (13.6 Nm) Maximum

The mounting hardware must include proper means to resist vibration loosening, such as thread-locking compound or locking hardware.

Once the mast is installed, see Section 5.8 for information on installing the pneumatic system.

5.7 Mast Installation: Internal Mount

This section describes installation of an internally mounted mast (Figure 5-13). These internal mounting instructions assume the use of an internal mounting kit (Section 3.3.4.2). For information on mounting the mast externally, see Section 5.6.

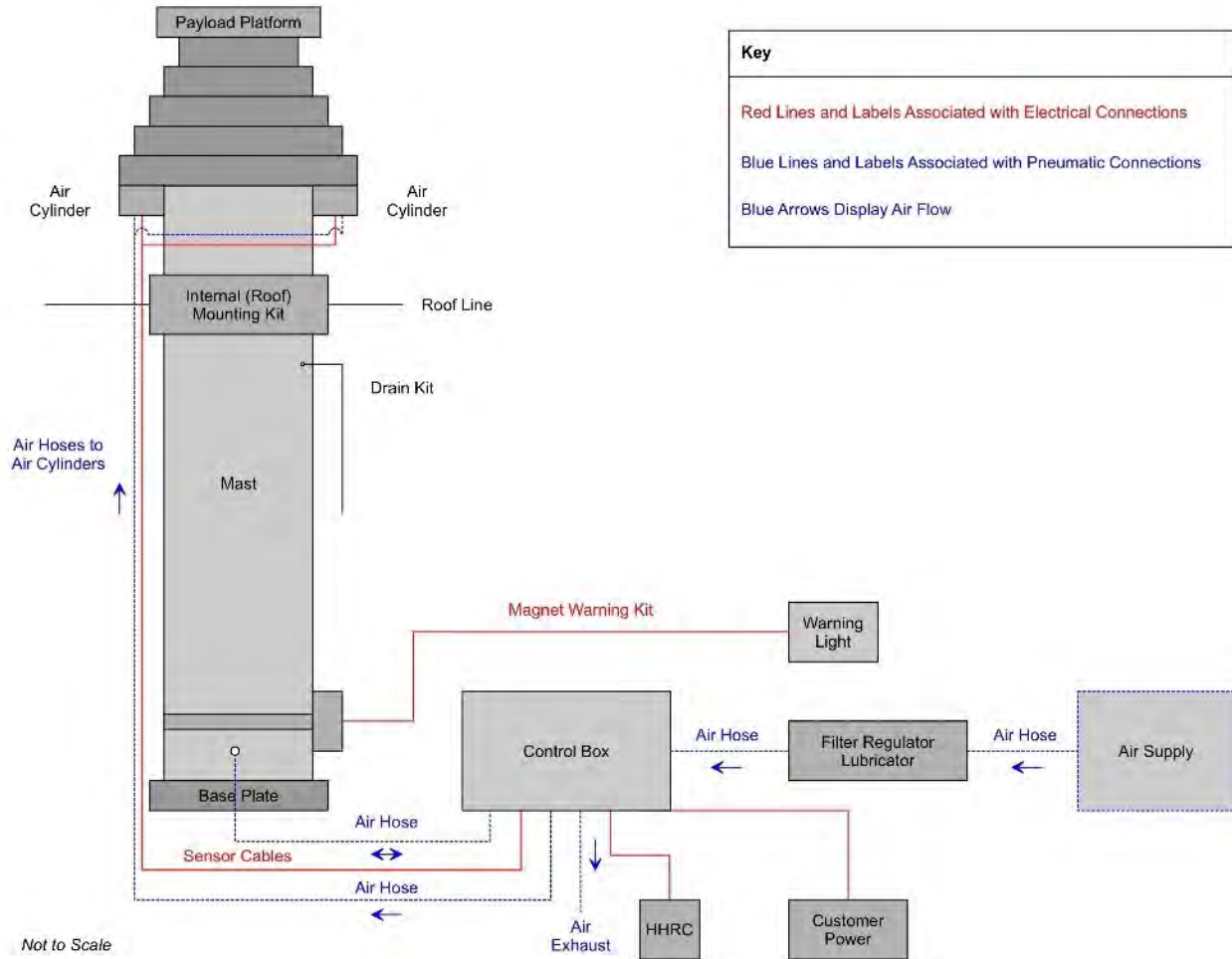

Figure 5-13 Typical Internal Mount Application

5.7.1 Internal Mount: Quick Summary

The following is a quick summary of the installation of an internally mounted mast. Detailed steps follow the quick summary (Section 5.7.2).

Install an internally mounted mast as follows:

1. Select a Suitable Mounting Location (Section 5.7.2.1)
2. Begin Installation of the Internal Mounting Kit (Section 5.7.2.2)
3. Lower Mast through the Internal Mounting Kit (Section 5.7.2.3)
4. Attach the Base Plate to the Mast (Section 5.7.2.4)
5. Position the Mast (Section 5.7.2.5)
6. Secure the Base Plate to the Mounting Surface (Section 5.7.2.6)
7. Complete Installation of the Internal Mounting Kit (Section 5.7.2.7)
8. Install the Control and Pneumatic Systems (Section 5.8)
9. Install the Drain Kit (Section 5.9)
10. Install the Magnetic Warning Kit (Vehicle Mount Applications) (Section 5.10)

5.7.2 Internal Mount Detailed Instructions

The following are detailed steps describing the installation of an internally mounted mast. The exact installation procedures may vary based on the configuration of the mast system being used and the installation environment.

5.7.2.1 Select a Suitable Mounting Location

To select a suitable mounting location, consider the following:

- The mounting area must have sufficient room to mount the mast system. The roof area must be as flat as possible at the location of the mast. The roofline must lie between the drain hole and RLS Guard. Mounting hardware must be at least 1 inch (25 mm) above the drain hole, and at least 3 inches (76 mm) below the RLS Guard. The exact dimensions of the mast system will vary based on the components included. Refer to Section 5.6 for dimension information.
- The mounting structure must be level in all directions, solid, and capable of holding the forces required by the bolts. Check the strength and rigidity of the mounting structure (e.g. vehicle body) where the mast system is to be attached. Reinforce as necessary.
- The area underneath the mast must be free of obstructions to allow for accessibility to base plate fasteners, and if present and used, the bottom air inlet port.
- The mounting location must have sufficient access for the pneumatic system.
- Before cutting the hole in the roof, it is advised to hang a plumb-bob from the roof to find the base plate location and ensure proper alignment between the roof hole and intended base plate location. This is particularly helpful when attempting to hit specific structural members beneath a vehicle.
- For mounting applications using a rotatable base plate, ensure the location of the mast allows enough clearance to accommodate the turning handles and the air hose if the air is routed to a side air inlet port. Rotatable Super Heavy Duty masts do not use turning handles but will need clearance for a customer-supplied rod to be inserted into the tube head to turn the mast.
- As mast tubes extend, they force water out of the weep holes. Keep any personnel or sensitive equipment away from the weep hole direction.

5.7.2.2 Begin Installation of the Internal Mounting Kit

To begin installation of the internal mounting kit:

1. Remove any roof liner or ceiling panels from the roof.
2. Cut a round hole in the roof $\frac{1}{4}$ inch (6.35 mm) larger than the diameter of the base tube (Section 4). Cut the same size hole in any roof liner or ceiling panels ensuring the hole will properly align with the hole in the roof when the roof liner or ceiling panels are reinstalled.
3. Center the ceiling plate from the internal mounting kit (Figure 5-14, Figure 5-15, or Figure 5-16) over the hole and use it as a template to drill bolt holes for attachment.

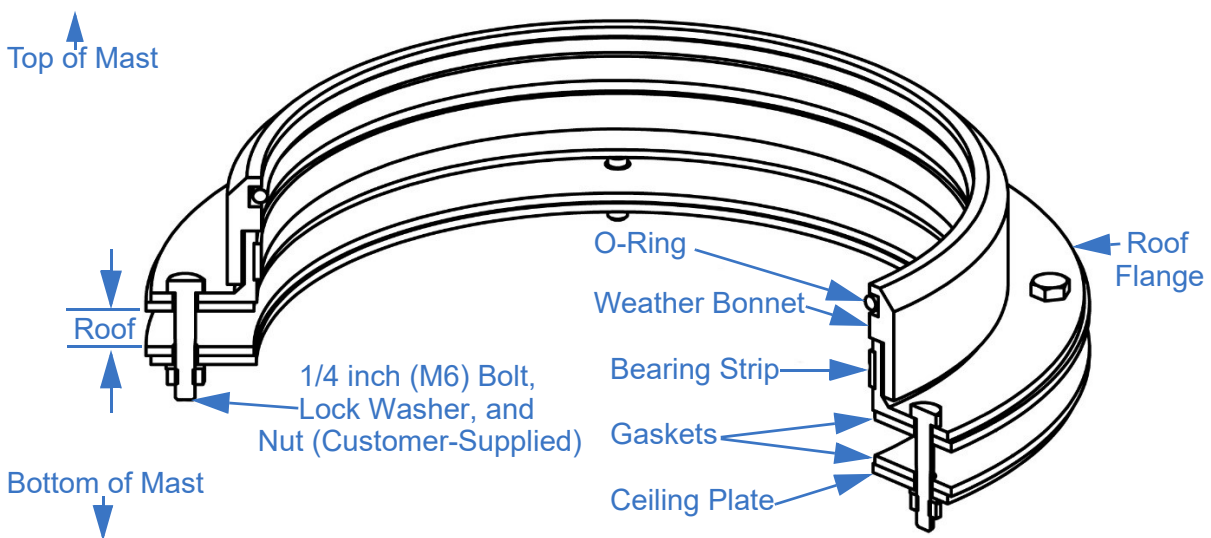

Figure 5-14 Internal Mounting Kit for Heavy Duty Masts (P/N: 905733)

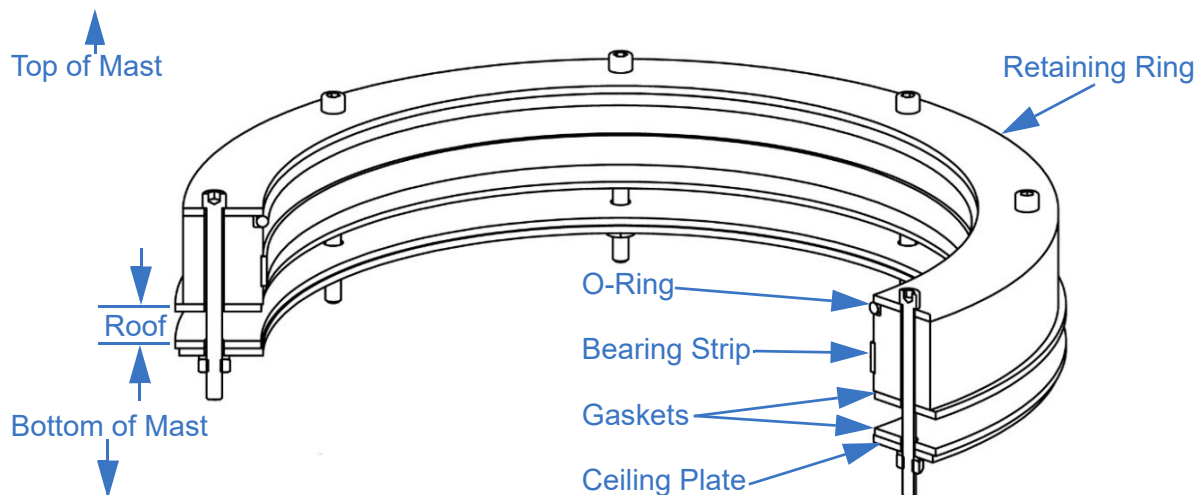

Figure 5-15 Internal Mounting Kit for Super Heavy Duty Masts (P/N: 910784 Shown)

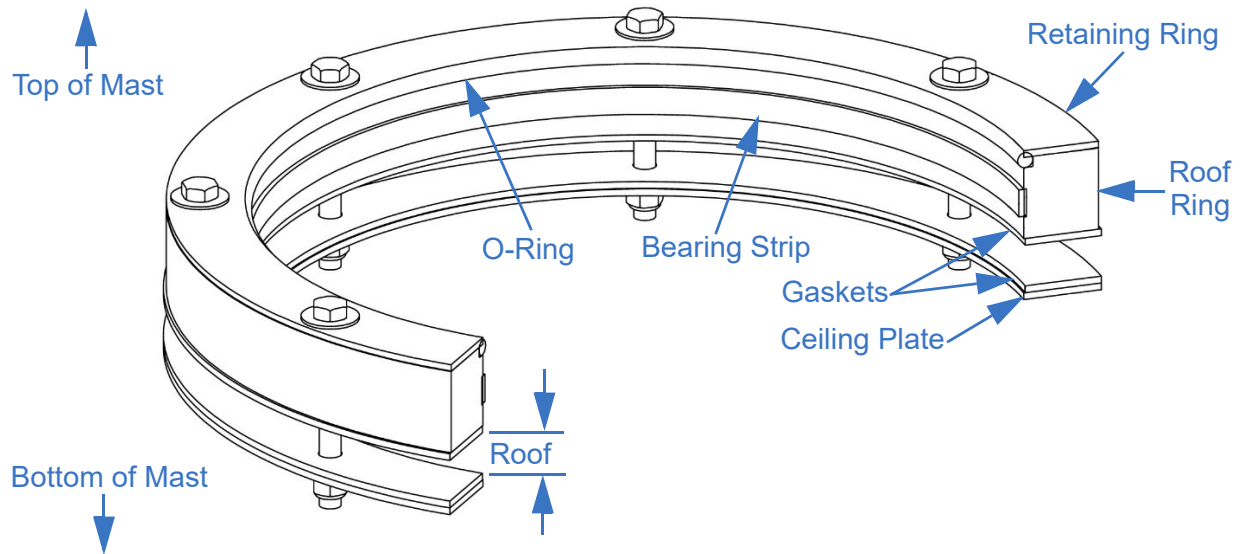

Figure 5-16 Ultra Heavy Duty Internal Mounting Kit (P/N: 5476101)

4. If necessary, use washers or short spacers made of $\frac{1}{4}$ inch (6.35 mm) pipe to level out any irregularities that exist in the roof.
5. Apply a bead of silicone sealant to both sides of one gasket.
6. For Heavy Duty Masts:
 - a. Line up the holes of the roof, the gasket with silicone sealant applied, and the roof flange (Figure 5-14). Ensure the gasket is between the roof and roof flange.
 - b. Replace any roof liner or ceiling panel.
 - c. Fit the other gasket (Figure 5-14) against the inside of the roof. This gasket does not need sealant. It will be held in place by the ceiling plate. Fit the ceiling plate in place and ensure all holes align.

d. Fasten this assembly (Figure 5-17) together using:

- i. ¼ Inch (M6) Bolts
- ii. ¼ Inch (M6) Lock Washers
- iii. ¼ Inch (M6) Nuts

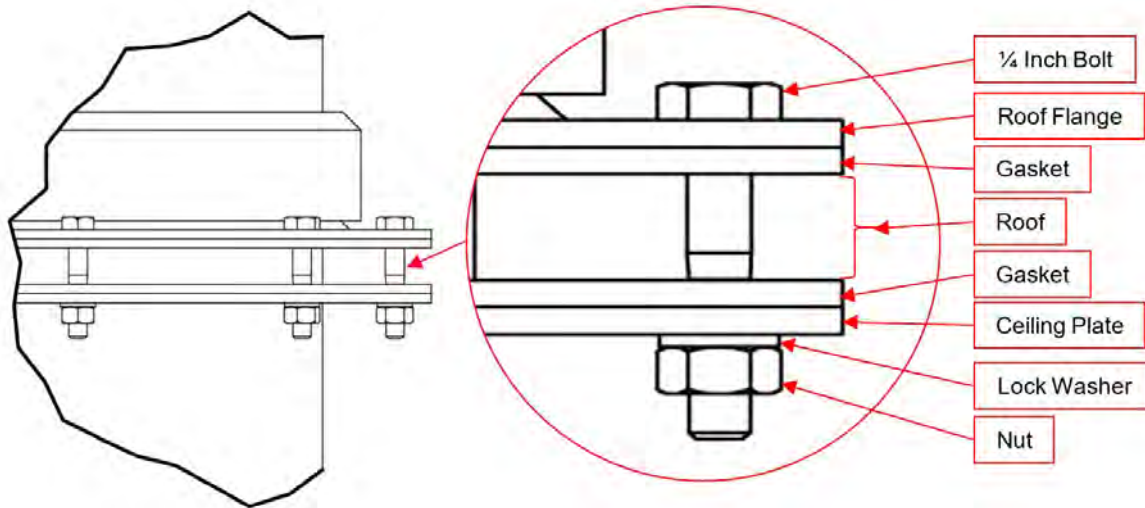

Figure 5-17 Fasten Assembly Together

The bolts should be sized to length to account for all components. The mounting hardware must include proper means to resist vibration loosening such as thread-locking compound or locking hardware. Torque all hardware as appropriate for its size and grade.

Note that the weather bonnet and o-ring are not yet installed (Figure 5-14).

- e. Clean off any silicone sealant that may have squeezed out the hole cut for the mast.
- f. Slide the weather bonnet and o-ring over the bottom of the base tube and up the mast past the drain hole towards the collar. If they are difficult to maneuver, put soapy water on the mast to allow them to slide more freely. Ensure the weather bonnet is oriented correctly, and the o-ring is in the notch in the weather bonnet (Figure 5-14).
- g. Temporarily secure the weather bonnet and o-ring in place so they cannot slide down the mast during transportation.
- h. Go to Section 5.7.2.3.

For Super Heavy Duty and Ultra Heavy Duty masts:

- a. Line up the holes in the roof, gasket, and roof ring (Figure 5-16). Ensure the gasket is between the roof and roof ring. Leave the retaining ring and o-ring off. These will be installed later.

For non-rotatable mast systems, leave the retaining ring and o-ring off. These will be installed later.

For rotatable mast systems, line up the holes in the retaining ring. Rotatable mast systems will have flashing kit instead of an o-ring. The flashing kit will be installed later.

- b. Replace any roof liner or ceiling panel.
- c. Fit the other gasket (Figure 5-14 and Figure 5-16) against the inside of the roof. This gasket does not need sealant. It will be held in place by the ceiling plate. Fit the ceiling plate in place and ensure all holes align.
- d. For non-rotatable mast systems, temporarily secure this assembly together. Do not torque hardware. Hardware will be torqued during final assembly.

For rotatable mast systems, fasten the assembly (Figure 5-18) together using:

- i. (8) ¼ inch (M6) Bolts
- ii. (8) ¼ inch (M6) Lock Washers
- iii. (8) ¼ Inch (M6) Nuts

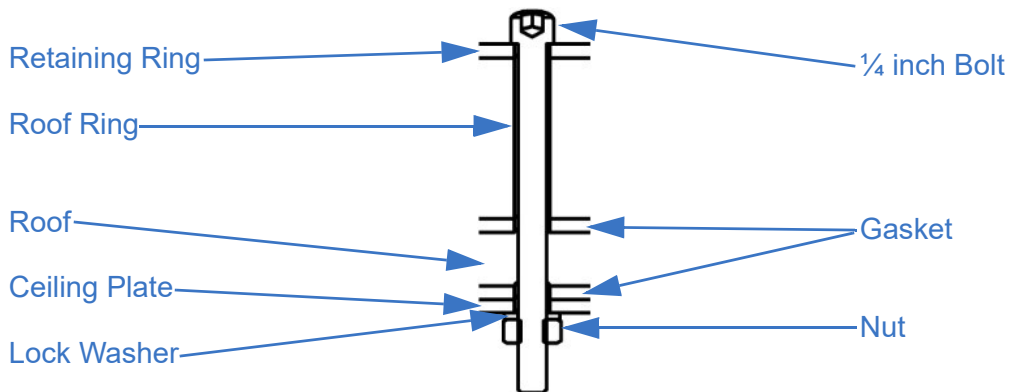

Figure 5-18 Fasten Assembly Together

The mounting hardware must include proper means to resist vibration loosening such as thread-locking compound or locking hardware. Torque all hardware as appropriate for its size and grade.

- d. Clean off any silicone sealant that may have squeezed out into the hole cut for the mast.

- e. For non-rotatable mast systems, slide the retaining ring and o-ring over the bottom of the base tube and up the mast past the drain hole towards the collar. If they are difficult to maneuver, put soapy water on the mast to allow them to slide more freely. Ensure the o-ring is below the retaining ring. Temporarily secure the retaining ring and o-ring in place so they cannot slide down the mast during transportation.

For rotatable mast systems, no actions are required at this time for the flashing kit. The flashing kit will be installed in Section 5.7.2.7.

5.7.2.3 Lower Mast through the Internal Mounting Kit

To lower the mast through the internal mounting kit:

1. Use a hoist to slowly lift the mast above the roof. Do NOT apply pressure to the air cylinders when lifting. Lifting with weight on the air cylinders could damage the mast. One possible means of lifting the mast would be to secure the hold down leashes to lugs on opposite sides of the base tube collar and connect the hold down leashes to the hoist. Depending on the environment and equipment available, other methods may work better. Use the best and safest method for your circumstances.
2. Align the base of the mast with the center hole of the internal mounting kit.
3. Carefully lower the mast partially through the roof. The mast should be held securely in position partially through the roof so that the installer has safe access to the base of the mast to install the base plate.

5.7.2.4 Attach the Base Plate to the Mast

The mast may use either a non-rotatable or rotatable base plate. Follow the appropriate installation instructions for your mast system. When installing the base plate to the base of the mast, ensure the mast is securely held in position.

Non-Rotatable Base Plates

To install a non-rotatable base plate:

1. Position the base plate against the base of the mast so the mounting holes align. Ensure the countersunk holes are facing away from the mast.
2. Secure the base plate to the mast with the (4) $\frac{3}{8}$ -16x1 flathead screws (P/N: 2772) from the hardware bag. Apply Loctite[®] 242/243 (Blue) or equivalent. Torque to 15.83-20 ft.-lb. (21-27 Nm).

Rotatable Base Plates

To install a rotatable base plate:

1. Back the locking screws far enough out of the base plate to allow the base plate to fit over the end of the mast.
2. Slide the base plate over end of the mast.
3. Tighten down the locking screws to secure the base plate to the mast.

5.7.2.5 Position the Mast

To position the mast:

1. Lower the mast the rest of the way to the floor.
2. Carefully, move the mast into position ensuring the mast is level. It is necessary to check the mast in two places 90° apart when leveling. Be certain to orient the mast so the operator has a clear view of the hazard labels.

Note: Additional labels are provided with the operator's manual and should be installed where the operator will have a clear view of them while operating the mast.

5.7.2.6 Secure the Base Plate to the Mounting Surface

To secure the base plate to the mounting surface:

1. Use the base plate as a template to drill holes through the mounting surface.
2. Ensure the base plate and mast are level in all directions. It is necessary to check the mast in two places 90° apart when leveling.
3. Secure the base plate to the mounting surface with appropriate hardware. To secure the base plate, the hardware bag contains:
 - a. (4) $\frac{3}{8}$ -16x1- $\frac{1}{2}$ Inch Bolts (P/N: 901594)
 - b. (4) Flat Washers (P/N: 2054)
 - c. (4) Lock Washers (P/N: 0801)
 - d. (4) Nuts (P/N: 901593)

Depending on the customer-specific mounting application, other (customer-supplied) hardware may be required. The mounting hardware must include proper means to resist vibration loosening such as thread-locking compound or locking hardware. Torque to 15.83-20 ft.-lb. (21-27 Nm).

5.7.2.7 Complete Installation of the Internal Mounting Kit

This section describes completing the installation of the Internal Mounting Kit as follows:

- Non-Rotatable Heavy Duty Masts
- Non-Rotatable Super Heavy Duty and Ultra Heavy Duty Masts
- Rotatable Heavy Duty Masts
- Rotatable Super Heavy Duty Masts
- Turning Handles

The exact installation procedures will vary depending on the configuration of the mast system. Follow the appropriate installation instructions for your configuration.

Non-Rotatable Heavy Duty Masts

To complete installation, slide the weather bonnet, with the o-ring in the notch, down the mast and over the roof flange. If the weather bonnet is difficult to maneuver, put soapy water on the mast to allow them to slide more freely.

Non-Rotatable Super Heavy Duty and Ultra Heavy Duty Masts

To complete installation:

1. Remove the hardware securing the roof ring. Ensure the ceiling plate and gasket underneath the roof do not fall.
2. Slide the retaining ring and o-ring down the mast.
3. Press the o-ring into the notch around the roof ring.
4. Position the retaining ring into place and ensure all the holes of the internal mounting kit align with the holes in the roof.

5. Fasten this assembly (Figure 5-19) together using:
- (8) ¼ Inch (M6) Bolts
 - (8) ¼ Inch Lock Washers
 - (8) ¼ Inch Nuts

The mounting hardware must include proper means to resist vibration loosening such as thread-locking compound or locking hardware. Torque all hardware as appropriate for its size and grade.

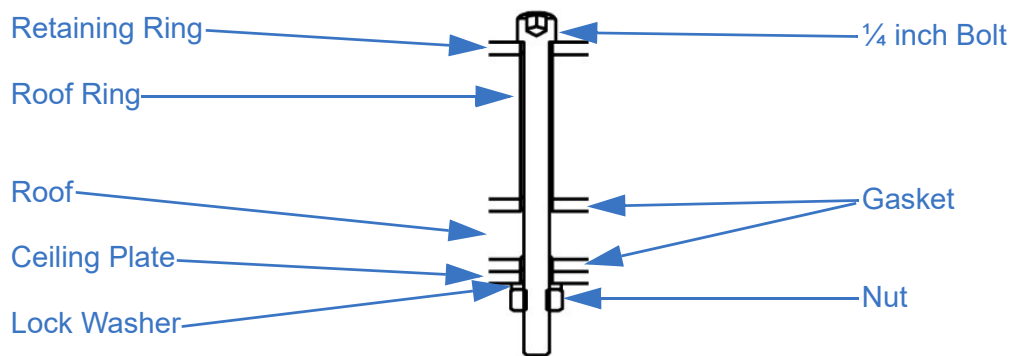

Figure 5-19 Fasten Assembly Together

Once the mast is installed, see Section 5.8 for information on installing the pneumatic system.

Rotatable Heavy Duty Masts

To complete installation, slide the weather bonnet, with the o-ring in the notch, down the mast and over the roof flange. If the weather bonnet is difficult to maneuver, put soapy water on the mast to allow it to slide more freely.

Rotatable Super Heavy Duty Masts

This section describes installing the flashing kit. If retrofitting a mast to use a flashing kit, see *Installing the Internal Mount Flashing Kit* (TP-5351001). To obtain this document, contact The Will-Burt Company.

To complete installation:

1. With the paper on the tape, position the flashing halves around the mast. Allow the flashing halves to rest on the internal mount.
2. Raise the flashing halves $\frac{1}{8}$ inch (3 mm).
3. Ensure there will be no obstructions with the sealant or roof line when the mast rotates and mark the top of the flashing halves with a pencil.
4. Remove the paper from the tape, and position the flashing halves so they align with the pencil mark.
5. Secure the flashing kit tight to the mast with:
 - a. (6) $\frac{1}{4}$ -20x0.75 Inch Bolts (P/N: 4542)
 - b. (12) $\frac{1}{4}$ Flat Washers (P/N: 0800)
 - c. (6) Nyloc Nuts (P/N: 1930)

Do not overtighten the flashing kit because tightening too much can deform the base tube and impede the movement of the next internal section.

6. Inspect the seal and add any tape if required.

Turning Handles

Turning handles ship with rotatable base plates to assist in rotating the mast. Note that rotating Super Heavy Duty masts do not use turning handles.

To secure the turning handles:

1. Determine the desired location for the turning handles. If feasible, The Will-Burt Company recommends installing above the drain hole. Do not cover drain hole with the turning handles.
2. Secure the band clamp halves together around the mast with:
 - (2) ¼-20x1.50 Hex HD Bolts (P/N: 2000)
 - (2) ¼-20 Nyloc Nuts (P/N: 1930)

Tighten the turning handle bolts just enough to allow the turning handles to turn the mast without slipping. Overtightening the turning handle bolts can deform the base tube and impede the movement of the next internal section.

For masts with:

- Ø 5.00 Inch Base Tube: Torque to 60 in.-lb. (6.8 Nm) Maximum
- Ø 6.75 Inch Base Tube: Torque to 100 in.-lb. (11.3 Nm) Maximum
- Ø 9.00 Inch Base Tube: Torque to 120 in.-lb. (13.6 Nm) Maximum

The mounting hardware must include proper means to resist vibration loosening such as thread-locking compound or locking hardware.

Once the mast is installed, see Section 5.8 for information on installing the pneumatic system.

5.8 Install the Control and Pneumatic Systems

This section describes general procedures and concepts to keep in mind when installing the control and pneumatic systems. Depending on the components of the mast system and the environment, the exact configuration and procedures may vary. Use the best and safest method for your conditions.

The control box requires:

- 9-40 volts power and has a 3 amp draw
- A clean, dry air supply capable of providing a minimum of 3 CFM and a minimum of 15 psi to the locks. The air supply should be regulated not to exceed the maximum operating pressure of 35 psi (241 kPa) for the mast at any time

5.8.1 Control and Pneumatic Systems Installation Quick Summary

The following is a quick summary of installation of the control and pneumatic systems. Detailed steps follow the quick summary (Section 5.8.2).

In general, install the control and pneumatic systems as follows:

1. Install the Drain and Relief Fittings (Section 5.8.2.1)
2. Install the Air Supply (Section 5.8.2.2)
3. Install the Control Box (Section 5.8.2.3)
4. Connect the Air Supply to the Control Box (Section 5.8.2.4)
5. Connect the Control Box to the Mast (Section 5.8.2.5)
6. Exhaust the Control Box (Optional) (Section 5.8.2.6)
7. Connect the HHRC to the Control Box (Optional) (Section 5.8.2.7)
8. Connect Customer Power to the Control Box (Section 5.8.2.8)

5.8.2 Control and Pneumatic Systems Installation Detailed Instructions

The following are detailed steps of installation of the Control and Pneumatic Systems. The exact installation procedures may vary based on the configuration of the mast system being used and the installation environment.

5.8.2.1 Install the Drain and Relief Fittings

To install the drain and relief fittings:

1. Locate the hardware bag (Section 3.3.1.1). Components from the hardware bag will be used during installation of the pneumatic system.
2. Locate the air inlet port to be used. When installing the pneumatic system, only use one air inlet port.
 - To use the air inlet port with the plastic plug:
 - a. Remove the plastic plug. This plug is for thread protection only and the mast should never be pressurized with this plug installed.
 - To use the air inlet port with the stainless steel plug:
 - a. Remove the plastic plug.
 - b. Remove the stainless steel plug.
 - c. Install the stainless steel plug in the air inlet port that is not going to be used to attach the pneumatic system. Pipe thread sealant or PTFE tape should be applied to minimize leakage.

Note: The plastic plug is for thread protection only. The mast should never be pressurized with the plastic plug installed. Ensure any unused air inlet port is plugged with a stainless steel plug.

3. Attach the brass cross to the desired air inlet port with a close Nipple, $\frac{3}{8}$ x $\frac{1}{4}$ bushing, and $\frac{1}{2}$ x $\frac{3}{8}$ bushing (Figure 5-20). Apply PTFE Tape to all threaded joints. If necessary, air hose may be used to connect between the air inlet port and the brass cross, however, the brass cross should be installed as close to the mast as possible to ensure proper drainage.

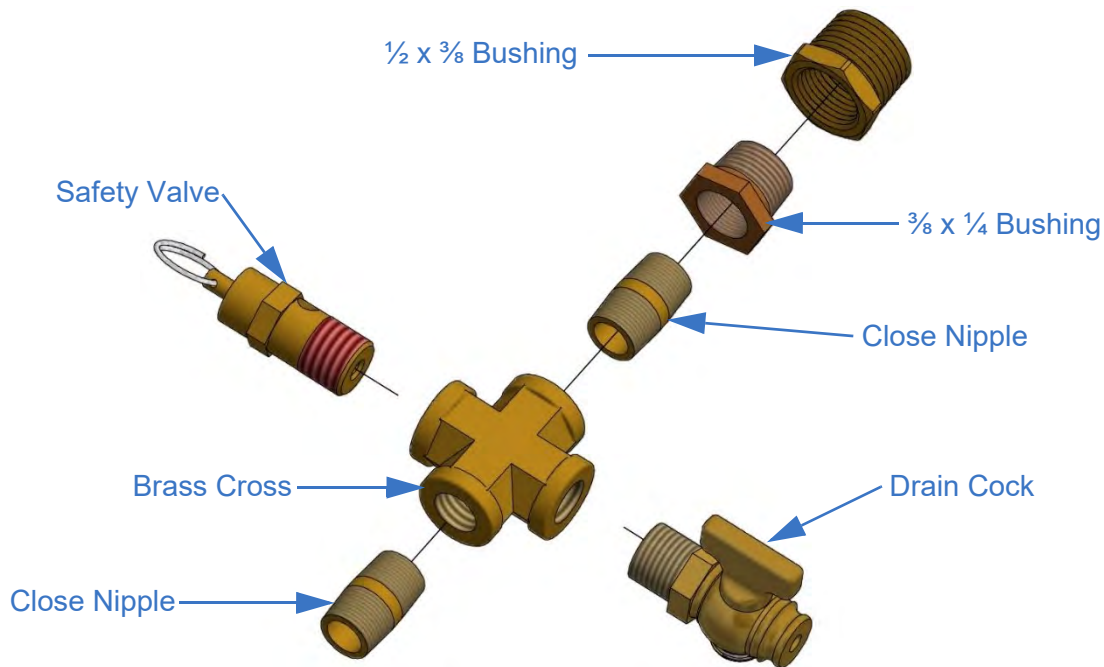

Figure 5-20 Pneumatic System Installation

4. Attach the safety valve to the brass cross. Apply PTFE Tape to all threaded joints.
5. Attach the drain cock to the brass cross. Apply PTFE Tape to all threaded joints.

Note: The drain cock should be located at the lowest point. When the mast is not in use, or when a locking mast is deployed and depressurized, the drain cock shall be left open. If the drain cock is not left open when not in use, it can collect condensation and fill up with water. This water can freeze, which causes the mast to not function correctly or break.

5.8.2.2 Install the Air Supply

When installing, keep the following in mind:

- **Mounting:** When mounting the pneumatic system, leave enough space around the unit for ventilation and for access to make initial installation, periodic adjustments, and future maintenance procedures as easy as possible. To reduce vibration in the system, place rubber washers or grommets on the bolts between the mounting pads and the mounting surface. To reduce noise, separate the system from inside the workspace (e.g. the workspace of a vehicle).
- **Electrical:** In accordance with applicable electrical codes, select the proper wiring size, circuit breakers, or fuse size according to the maximum current draw of the pneumatic system being installed. Refer to the rating information plate on the compressor motor. Be sure to properly ground the compressor motor and all other electrical components. Operation of the compressor may cause interference unless proper isolation or shielding is used. A qualified electrician should perform installation and adjustments.
- **Air Supply:** The air supply should have adequate ventilation to provide a sufficient amount of clean, dry air at the air intake at all times. The air supply should not be operated without the air filters in place.
- **Drain and Relief Fittings:** A drain cock and safety valve must be installed to an air inlet port at the base of the mast. The drain cock empties water that may have accumulated inside the mast. The drain cock shall be opened to drain the mast when not in use, or when a locking mast is extended and depressurized. The drain cock should be left open once the mast is fully retracted. The safety valve prevents the mast from being over-pressurized.
- **Plumbing:** A length of air hose with an ID of $\frac{3}{8}$ inch (9.5 mm), plus additional loose fittings, are supplied with a The Will-Burt Company's pneumatic system if purchased. The air hose can be cut to the required length at installation. Do not remove any hose without first completely exhausting all air from the mast and then disconnecting the power supply.

To install the air supply:

1. If necessary, mount the air supply to the mounting structure with appropriate hardware. The mounting hardware must include proper means to resist vibration loosening such as thread-locking compound or locking hardware. Torque all hardware as appropriate for its size and grade.
2. If necessary, connect customer power to the air supply. Be certain to observe any local codes or regulations.

Note: The air supply should not be operated without air filters in place.

5.8.2.3 Install the Control Box

The control box can be installed outside or inside an enclosure such as the cab of a vehicle. When installing, ensure adequate space is available around the control box to allow for connection of air hoses and electrical cables. Eventually, the following will be connected to the control box:

- Air Hose from the Air Supply
- Air Hose to the Drain and Relief Fittings at the Base of the Mast
- Air Hose to the Air Cylinders
- Air Hose to Exhaust the Mast (Optional)
- Sensor Cable to the Air Cylinders
- Power Cables from the Power Supply
- HHRC (Optional Installation)

If desired, the control box feet can be rotated 90° before installation.

To reorient the control box feet:

1. Unscrew the control box feet.
2. Rotate the control box feet into the desired position.
3. Re-secure the control box feet.



Figure 5-21 Control Box Feet

To install the control box:

1. Use the control box as a template to drill four mounting holes into the mounting structure.
2. Secure the control box using four ¼ inch (M6) screws. Torque all hardware as appropriate for its material and size. The mounting hardware must include a proper means to resist vibration loosening such as thread-locking compound or locking hardware.

5.8.2.4 Connect the Air Supply to the Control Box

To connect the air supply to the control box:

1. Route a $\frac{3}{8}$ inch air hose from the air supply to the control box. A filter regulator lubricator or filter lubricator can be run in-line between the air supply and the control box. If routing the air hose through a structure, The Will-Burt Company recommends the use of a grommet or equivalent to protect the air hose.

Note: If the system shipped with a 12 mm hose (P/N: 5825901, P/N: 5826001, P/N: 5826101, or P/N: 5826201), remove the 3/8 hose fitting from the air inlet on the control box and replace it with the 12 mm hose that is supplied with the system. Not all systems ship with a 12 mm hose.

2. Connect the air supply to the control box through the “AIR IN” push connect (Figure 5-22).

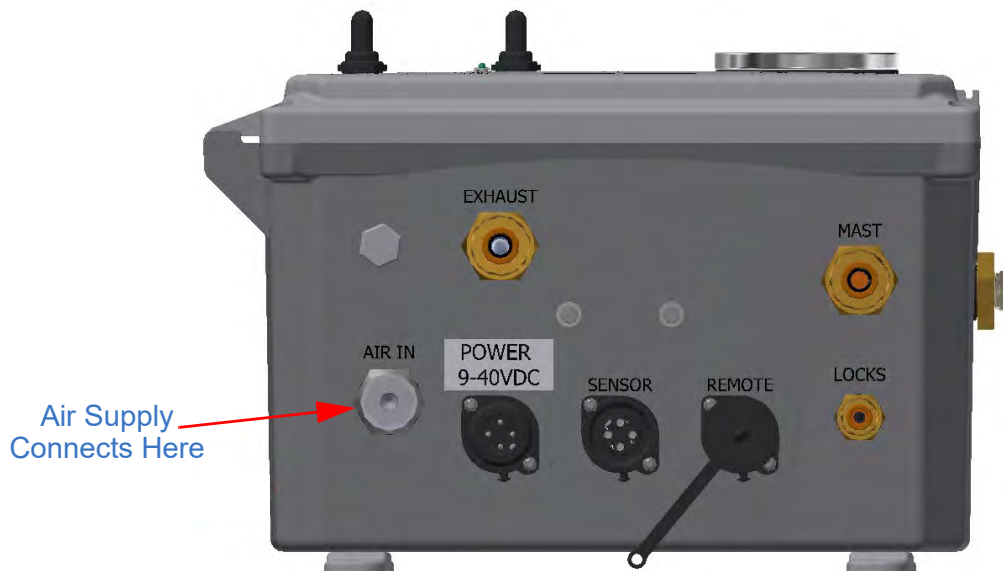

Figure 5-22 Control Box “AIR IN” Connection

5.8.2.5 Connect the Control Box to the Mast

To connect the control box to the mast:

1. Remove the RLS Guard.
2. Connect the $\frac{3}{8}$ inch air hose (P/N: 108768) to the “MAST” connection on the control box (Figure 5-23).

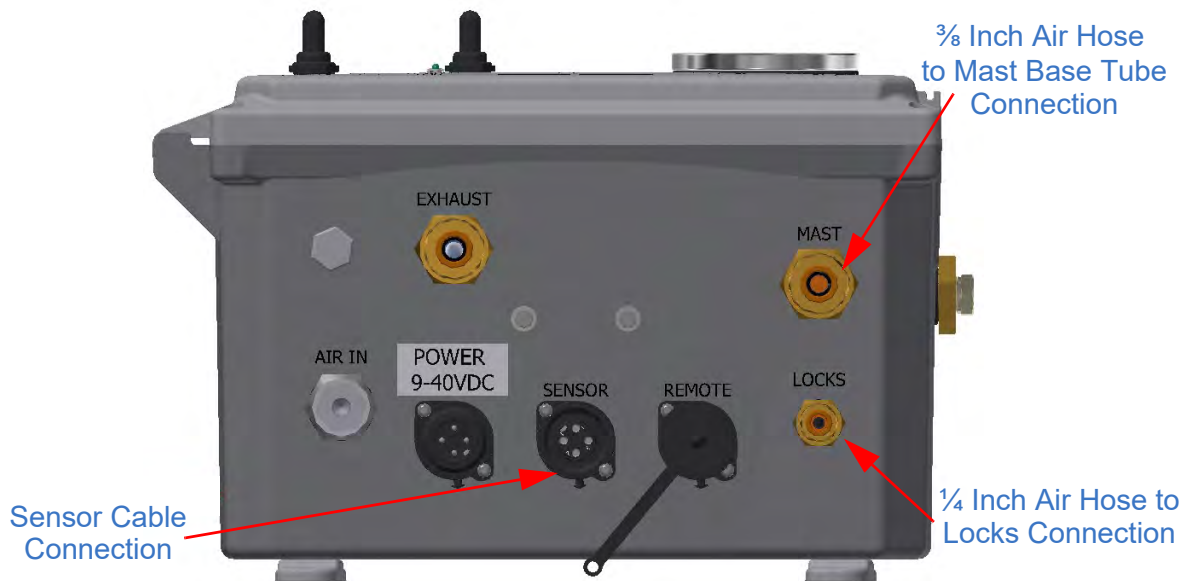

Figure 5-23 Control Box to Mast Connections

3. Route the air hose (P/N: 108768) to the base of the mast. If routing the air hose through a structure, The Will-Burt Company recommends the use of a grommet or equivalent to protect the air hose.
4. As necessary, trim the air hose to the desired length.
5. Connect the air hose (P/N: 108768) to the drain and relief fittings. The air hose will use a close nipple, part of the hardware bag (Section 3.3.1.1), to connect to the brass cross. Apply PTFE Tape to all threaded joints.
6. Connect the $\frac{1}{4}$ inch air hose (P/N: 5558001) to the “LOCKS” connection on the control box (Figure 5-23).
7. Route the air hose (P/N: 5558001) to the mast so that it can reach the locks. If routing the air hose through a structure, The Will-Burt Company recommends the use of a grommet or equivalent to protect the air hose.
8. As necessary, trim the air hose to the desired length.
9. Each mast lock has an air hose that runs from the lock to a “T”. Connect the air hose from the control box to the “T”.

10. Connect the sensor cable (P/N: 5567601) to the “SENSOR” connection on the control box (Figure 5-23).
11. Route the sensor cable to the mast so that it can reach the reed switches on the locks. If routing the sensor cable through a structure, The Will-Burt Company recommends the use of a grommet or equivalent to protect the sensor cable. It may be possible to use the same grommet used to route the ¼ inch air hose (P/N: 5558001).
12. Secure the sensor cable to the reed switches.
13. Reinstall the RLS Guard.

Note: The installer may want to wait until the mast has been tested (Section 5.12) before reinstalling the RLS Guard.

5.8.2.6 Exhaust the Control Box (Optional)

If desired, a 3/8 inch air hose can be added to the “EXHAUST” connection on the control box to route away moisture (Figure 5-24).

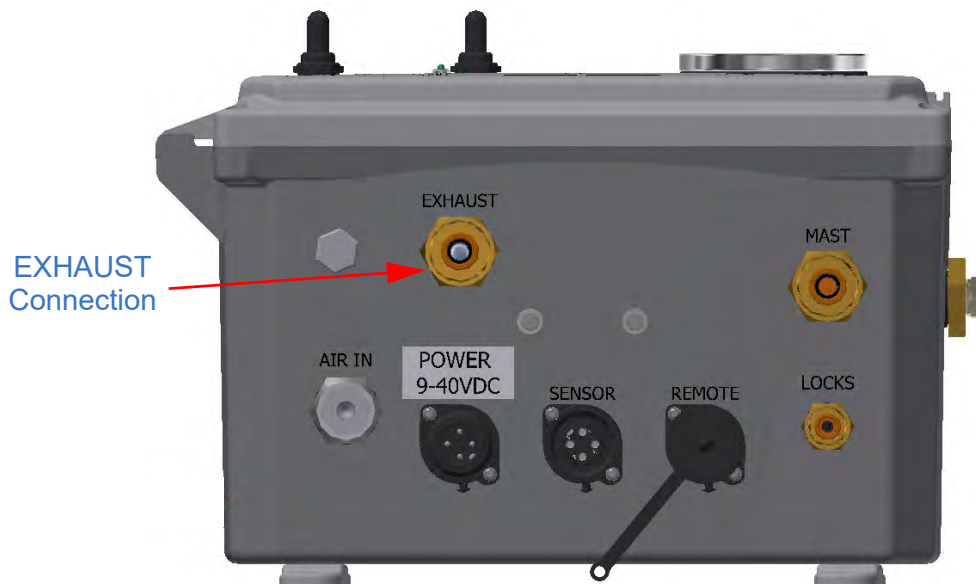

Figure 5-24 Control Box “EXHAUST” Connection

5.8.2.7 Connect the HHRC to the Control Box (Optional Installation)

If desired, the mast can be operated using an HHRC instead of directly through the control box. To connect the HHRC, plug the HHRC into the “REMOTE” plug on the control box (Figure 5-25).

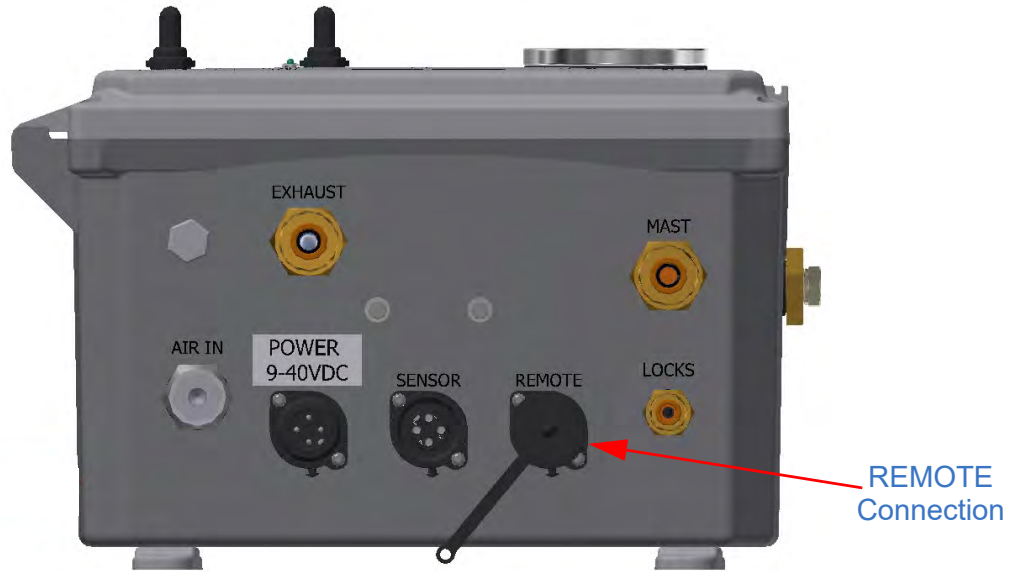

Figure 5-25 Control Box “REMOTE” Connection

The HHRC ships with a holder.

To secure the HHRC holder:

1. Use the holder as a guide to drill two holes on the mounting structure.
2. Secure the holder in place with two #8 (M4) flathead screws.

Note: To use the HHRC to control the mast, it will be necessary to select “REMOTE” on the “BOX/REMOTE” switch on the control box.

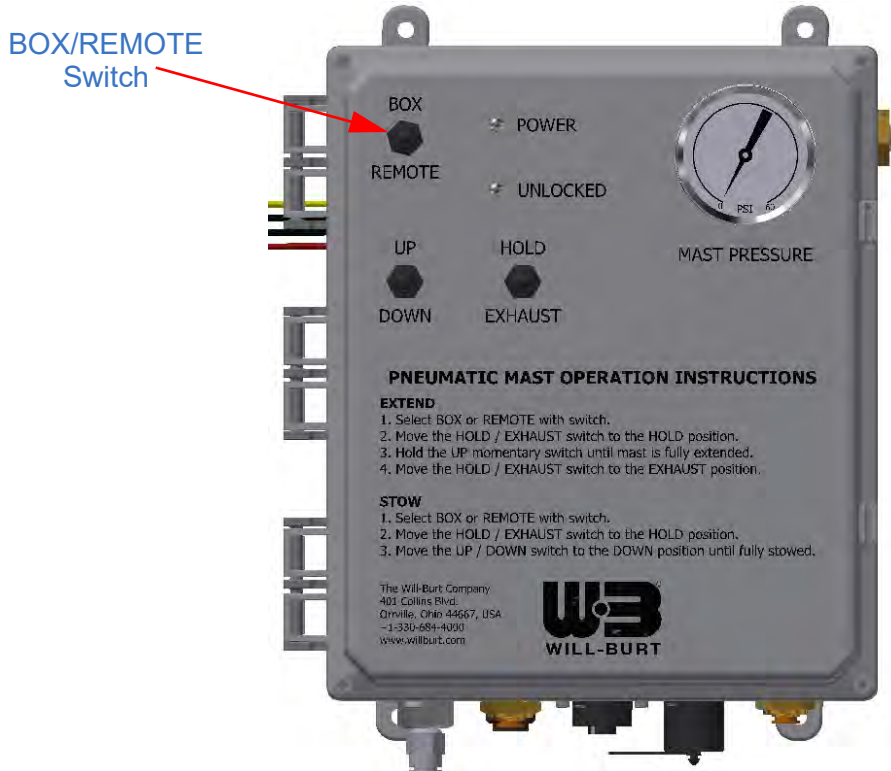

Figure 5-26 “BOX/REMOTE” Switch

5.8.2.8 Connect Customer Power to the Control Box

The control box does not have a master power switch. If a master power switch is desired, the customer must provide it in-line with the customer power. When wiring the customer power, be certain to observe any local codes or regulations. See Section 10.3 for the system wiring diagram.

To connect customer power to the control box:

1. Plug 20 gauge power cable (P/N: 5567501) into the “POWER” connection on the control box (Figure 5-27).

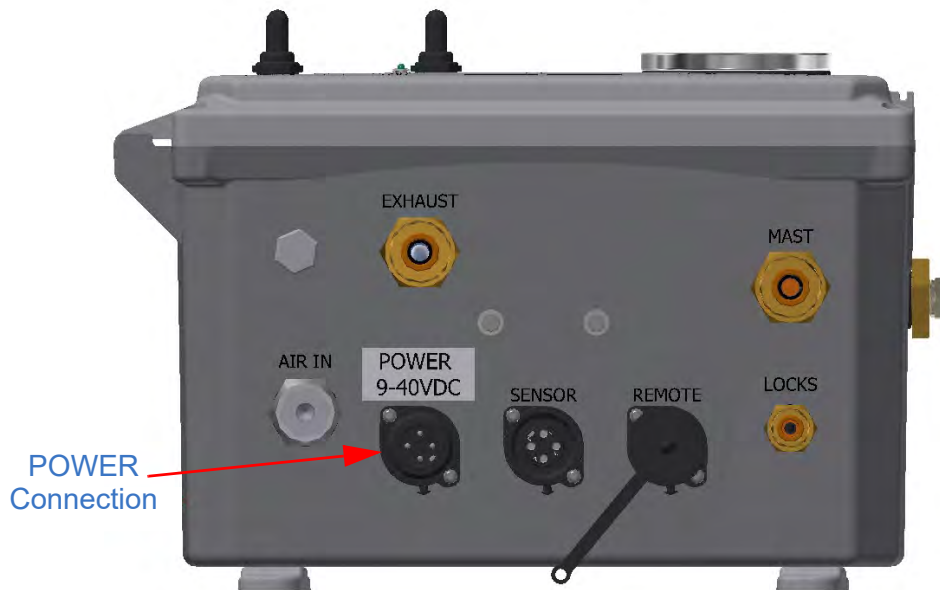

Figure 5-27 Control Box “POWER” Connection

2. Route the power cable to the customer power. If routing the power cable through a structure, The Will-Burt Company recommends the use of a grommet or equivalent to protect the power cable.
3. Wire the power cable to the customer power.

5.9 Install the Drain Kit

The drain kit is intended to protect the interior of a vehicle from damage due to water drainage, and is optional for externally mounted masts. However, the elbow from the kit may be used to shield the drain hole from blowing sand, dust, and other debris.

Keeping water out of the mast is very important to avoid potential delays in operations and damage to the mast. Water can enter the mast through condensation in the air supply, or by rain running down the tubes and entering at the collars. Water that freezes in the mast can cause the mast to work erratically, or not at all.

The drain hole on the base tube and weep holes on the intermediate tubes are located to facilitate the drainage of water during periods of extension. The drain kit is designed to route water from inside the mast to outside of the vehicle or enclosure. The drain kit is intended to protect the interior of a vehicle or other water sensitive area from damage due to water drainage. Drain kit installation is not required for externally mounted masts.

A drain cock, provided in the hardware bag, should also be connected to the air inlet near the base of the mast and located at the lowest point. The drain cock shall be opened when the mast is not in use, or when a locking mast is deployed and depressurized, to empty water that may accumulate inside the base tube, particularly after the mast has been exposed to rain. Installation of the drain cock is described as part of installation of the pneumatic system (5.8).

To install the drain kit:

1. Be certain the locknut and washer are threaded over the end of the ¼ inch (6.35 mm) hose adaptor (Figure 5-28).

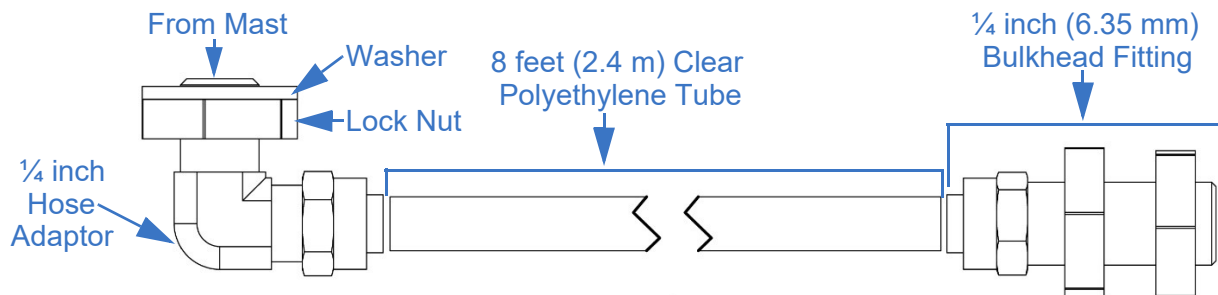

Figure 5-28 Drain Kit (P/N: 902982)

2. Fasten the hose adaptor to the drain hole (Figure 5-29). Apply PTFE Tape to all threaded joints. Turn the hose adaptor in ONLY 1 ½ to 2 times after initial engagement of the threads. Turning further will damage the mast. Tighten the locknut to secure the hose adaptor in place. Overtightening could cause the hose adaptor to contact the moving intermediate tube.

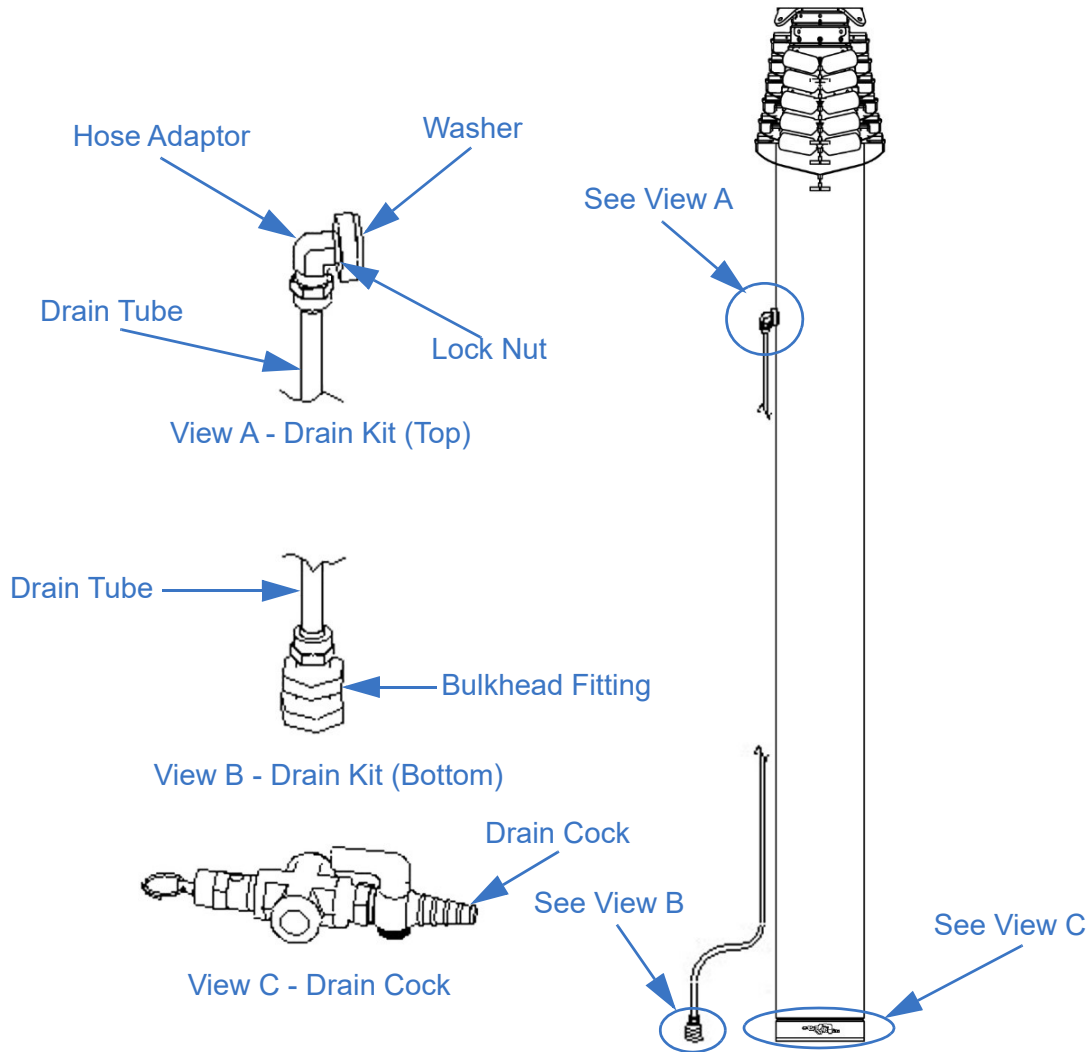

Figure 5-29 Ultra Heavy Duty Drain Kit Installation

3. Drill a hole in the vehicle or enclosure to route the water outside.
4. Fasten the bulkhead fitting (Figure 5-29) to the hole.
5. Attach the polyethylene tube to the hose adaptor and the bulkhead fitting (Figure 5-29). As necessary, the polyethylene tube may be cut shorter to fit the customer-specific application. Apply PTFE Tape to all threaded joints.

5.10 Install the Magnetic Warning Kit

When installing the mast system on a vehicle, the magnetic warning kit shall be installed to provide a warning against moving the vehicle while the mast is partially or fully extended. When correctly installed, flashing lights will indicate partial or full extension of the mast when the ignition is on. When the mast is properly nested, or the ignition is off, the lights will cease to illuminate. The lead to the positive battery terminal should be connected to the ignition switch so the lights will only illuminate when the mast is extended and the ignition is on. The operator should always visually confirm that the mast is entirely retracted before moving the vehicle. Be certain to observe any local codes or regulations.

To install the magnetic warning kit:

1. Tie one end of a piece of rope or wire to the top of the magnet through the eyebolt (Figure 5-30).

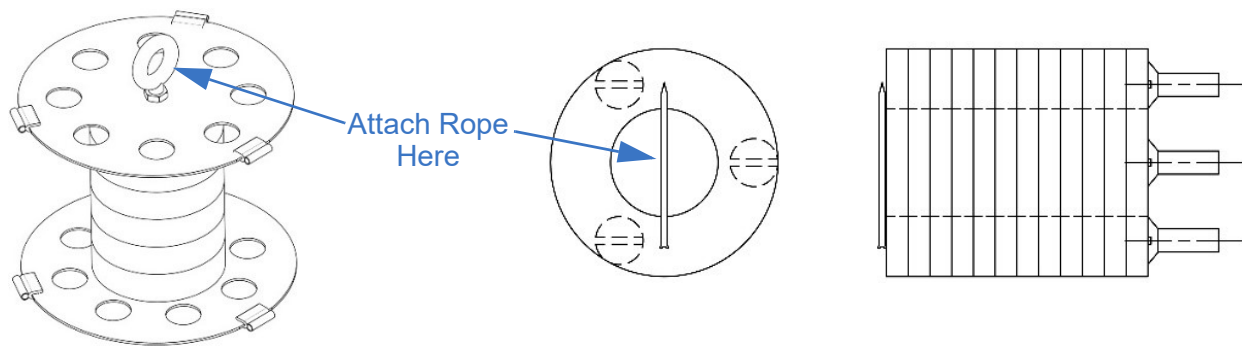

Figure 5-30 Magnet

2. Carefully lower the magnet into the top of the top tube.
3. Using the rope, lower the magnet to the bottom of the top tube. It is important that the magnet is resting on the bottom end of the top tube. Cut off the excess rope.
4. Assemble the magnetic switch assembly and the stainless steel band.

5. Attach the magnetic switch assembly loosely around the base tube approximately 6 to 20 inches (15 to 51 cm) above the base plate (Figure 5-31). The magnetic switch assembly can be located anywhere around the perimeter of the base tube.

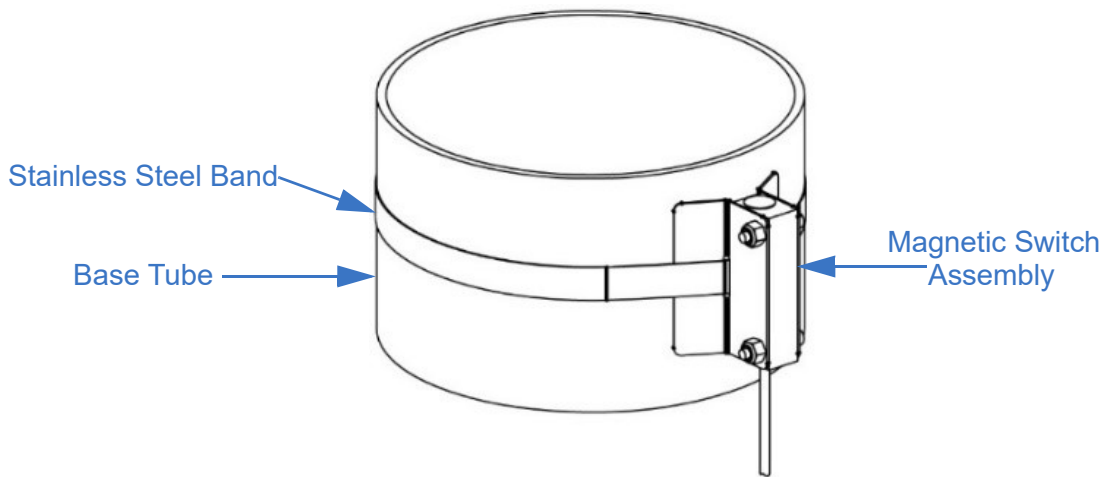

Figure 5-31 Magnetic Switch Assembly Attached to Base Tube

6. For applications with a relay, mount the relay. Do not mount the relay any closer than 6 inches (15 cm) from the magnetic switch assembly that is clamped to the mast. When energized, the relay produces an electromagnetic field that could affect the performance of the reed switch in the magnetic switch assembly if the relay is mounted too close.
7. Mount the flasher, keeping in mind that wire will eventually need to be routed from the magnetic switch assembly to the flasher. In applications with a relay, the wire will be routed from the magnetic switch assembly to the relay and then to the flasher.
8. Mount the lights, keeping in mind that wire will eventually need to be routed from the flasher to the lights. One flashing light should be mounted to the vehicle dash in full view of the driver.

9. For mast models:

- a. 7-30: Use 16 AWG stranded wire (customer-supplied) to connect the flasher and lights to the wires exiting the magnetic switch assembly (Figure 5-32).

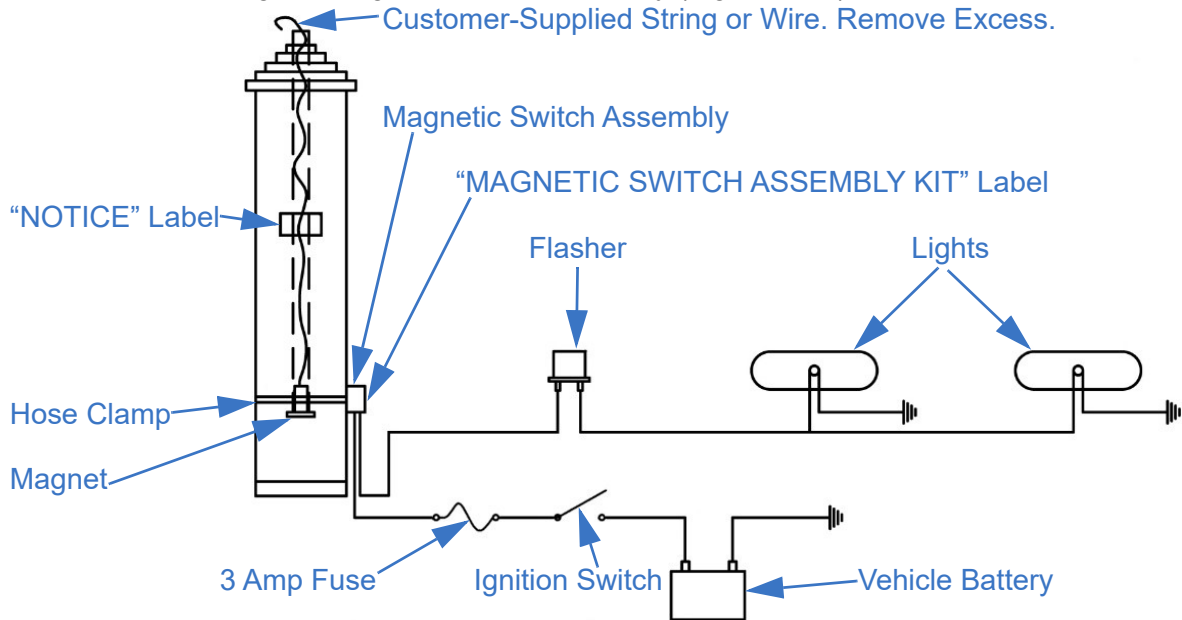

Figure 5-32 Wire the Magnetic Switch Assembly Kit

- b. 7-42, 9-50, 10-60, 10.3-60, 10.8-76, 8-39, 11.3-59, 9.8-65.6, and 14.3-80: Use 16 AWG stranded wire (customer-supplied) to connect the flasher, lights, and relay to the wires exiting the magnetic switch assembly (Figure 5-33 and Figure 5-24).

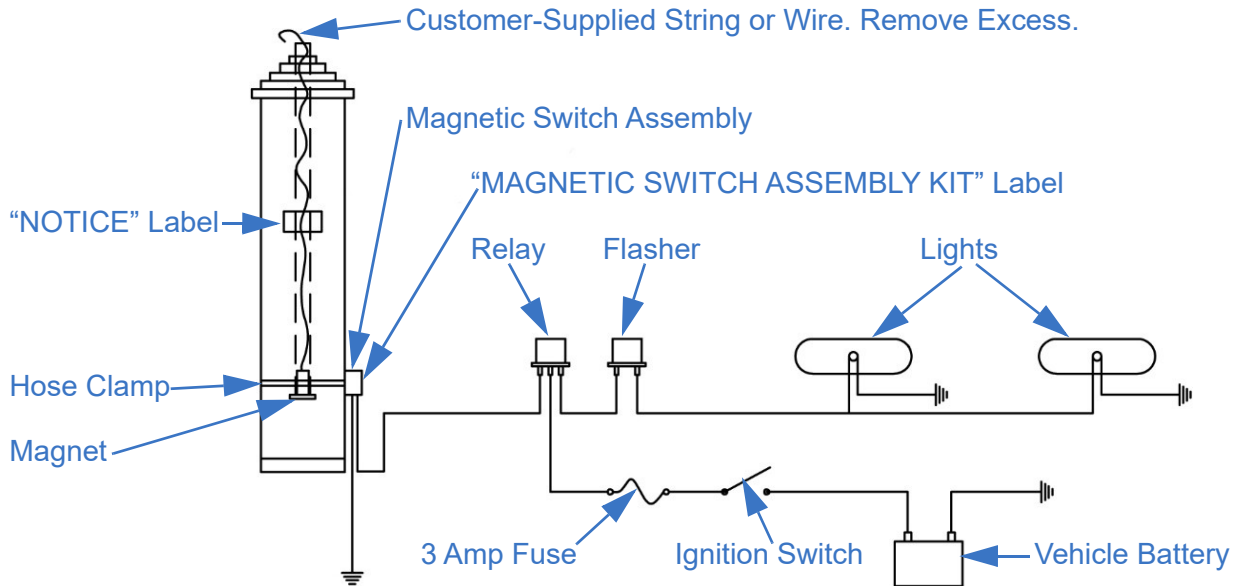

Figure 5-33 Wire the Magnetic Switch Assembly Kit

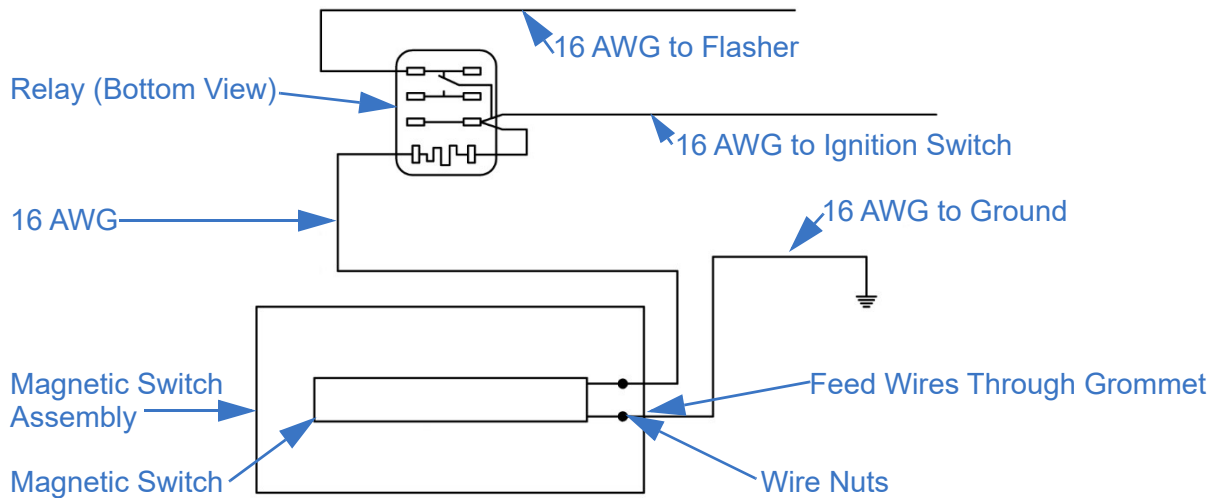

Figure 5-34 Relay and Magnetic Switch Assembly Wiring

10. Use customer-supplied 16 AWG stranded wire to connect the magnetic switch assembly to vehicle power through the ignition.
11. Ensure:
 - a. The mast is fully nested.
 - b. The flasher and lights are installed and connected to the ignition through the battery.
 - c. The ignition is on.

Note: The light should be flashing unless the switch is in contact with the magnet assembly.
12. Slide the magnetic switch assembly up and down the lower two feet (60 cm) of the base tube to locate the magnet assembly inside the tube. When the magnet assembly is located, the lights will stop flashing. The vertical sensing range should be about 1 to 3 inches (2.5 to 7.5 cm).
13. Tighten the band to clamp the switch assembly within the sensing range ensuring it is not lower than 1 inch (2.5 cm) above the lower limit of the sensing range. The 1 inch (2.5 cm) allows for seasonal variations in the top tube position.
14. Attach the “NOTICE” label in a visible area on the base tube (Figure 5-33).
15. Attach the “MAGNETIC EXTENSION WARNING KIT” label to the magnetic switch assembly (Figure 5-33).
16. Extend the mast 1 to 2 feet (31 to 61 cm) and then nest the mast. Repeat several times to test the magnetic warning kit. For information on operating the mast system, see Section 6.3.

5.11 Additional Accessory Installation

Depending on the configuration of the mast system, optional components selected, or the installation environment, additional accessories and positioners may need to be installed. Install any additional accessories as appropriate. Contact The Will-Burt Company with any questions before performing any installation procedures.

5.12 Test the Installation

Follow all precautions while testing the mast system installation. The mast may operate better with a payload on it. For procedures on installing a test payload, see Section 5.13.

To test the installation:

1. Review the Pre-Operation Check.
2. Prepare the mast system for operation.
3. Extend the mast.
4. For rotatable applications, rotate the mast.
5. Lower the mast.

Note: The drain cock shall remain open to drain water when the mast is not in use. The drain cock shall be opened while a locking mast is deployed and depressurized to drain water. It is not uncommon to have mast grease exit the drain or exhaust valve on initial mast use.

See Section 6 for additional details on these procedures.

5.13 Install Payload

The exact installation procedures for payload will vary based on the customer-specific payload and payload platform or stud adaptor being used. For optimal performance, center the payload as best as possible. If offsetting any payload greater than 600 lb. (272 kg), the payload offset direction must be in-line with the tube keys, and not perpendicular to the keys. Contact The Will-Burt Company with any questions before performing any installation procedures.

In general, to install the payload:

1. Ensure the air supply is disconnected and the drain cock is opened while installing the payload to eliminate the possibility of inadvertent mast extension.
2. If necessary, remove the mast top cover.

Note: If the payload is removed, the mast top cover should be put back on.

3. Carefully move the payload into position.
4. Properly secure the payload to the mast. The mounting hardware must include proper means to resist vibration loosening, such as thread-locking compound or locking hardware. Torque all hardware as appropriate for its size and grade.

Note: If securing a payload part-way along a mast tube, be sure not to overtighten the tube, or damage to the mast could occur. Intermediate tubes clamps are available to assist in attaching payloads to the intermediate tubes. See www.willburt.com for additional information.

This page intentionally left blank.

6 Operation

This section describes the general operation of the mast system. Use care to understand and follow all precautions while operating.

6.1 Pre-Operation Check

Before operating the mast system, ensure:

- All operators read and understand the entire operation procedure and are properly trained.
- The mast system is undamaged. If damage is apparent, do not use the mast system, and have it serviced prior to use.
- All electrical cables are undamaged and properly terminated.
- The area is free of power lines or other overhead obstructions. The mast system location should be no closer than a horizontal distance equal to the extended height of the mast away from power lines.
- Any objects that might obstruct motion of the mast system, cause binding, or hinder mast system function are removed.
- The mast system and payload are properly installed.
- When using a vehicle, the vehicle is not moving and is on level terrain.
- Masts extended up to 60 feet (18.2 m) can be operated on terrain having a slope up to:
 - 5° of vertical for Ultra Heavy Duty masts with payloads of 200 lb. (90.7 kg) or less
 - 4° of vertical for Ultra Heavy Duty masts with payloads of 200 lb. to 800 lb. (90.7 kg to 362.9 kg)
 - 2° of vertical for Ultra Heavy Duty masts with payloads of 800 lb. to 1,200 lb. (362.9 kg to 544.3 kg)
 - 5° of vertical for Heavy Duty masts
- Ultra Heavy Duty Masts: Masts extended 60 ft. to 80 ft. (18.2 m to 24.4 m) can be operated on terrain having a slope up to:
 - 4° of vertical for payloads 600 lb. (272.2 kg) or less
 - 1° of verticals for payloads 600 lb. to 1,200 lb. (272.2 kg to 544.3 kg)Sail area could impact the mast deployment angle if the wind is blowing in the direction of the tilt. Consult factory.
- Any transit tie-downs have been removed.
- The mast system area is free of personnel.
- The operator has full view of the mast system during use.

6.2 Operation Equipment

Table 6-1 lists recommended equipment for operation.

Table 6-1 Equipment Recommended for Operation

Recommended Equipment*		
Personal Protective		
Safety Glasses	Work Gloves	Nitrile or Vinyl Gloves
Hearing Protection	Hard Hat or Helmet	Safety Shoes
* Depending on the local, regional, and national standards and codes of practice, and the environment, additional personal protective equipment may be necessary.		

6.3 Mast System Operation

This section describes operation of the mast system. The exact operating procedures may vary based on the configuration of your mast system. Follow the appropriate operation procedures for your mast system.

Operation of the mast system is described as follows:

- Prepare the Mast System for Operation (Section 6.3.1)
- Extend the Mast (Section 6.3.2)
- Stow the Mast (Section 6.3.3)

6.3.1 Prepare the System

To prepare the system for operation:

- Ensure the mast system is stationary on level, stable ground.
- Perform the Pre-Operation Check (Section 6.1)
- Prepare the pneumatic system for operation. As part of this:
 - Close the drain cock
 - Ensure the air supply is connected to the control box and operational
 - Ensure the control box has power (POWER LED will illuminate when power is present)
- If necessary, secure any cables to the mast
- If necessary, secure the payload to the mast (Section 5.13)
- Ensure the proper personnel are available to operate the mast. For applications using guy lines, a minimum of:
 - (2) People are necessary to operate the guy lines (guy lines must be operated opposite of each other)
 - (1) Person must observe the mast to ensure it is standing straight and not leaning in any direction. For taller masts, binoculars may be required.
 - (1) Person must operate the pneumatic system. It may be possible for the person observing the mast to also operate the pneumatic system.
- Ensure the mast is only being operated in safe wind speeds. Deployment and retraction wind speeds are payload dependent, however the mast can typically be deployed and retracted in winds speeds up to 25 mph (40 km/h) assuming:
 - 12 inch maximum offset payload from mast centerline
 - Masts extended up to 60 feet (18.2 m) can be operated on terrain having a slope up to:
 - 5° of vertical for Ultra Heavy Duty masts with payloads of 200 lb. (90.7 kg) or less
 - 4° of vertical for Ultra Heavy Duty masts with payloads of 200 lb. to 800 lb. (90.7 kg to 362.9 kg)
 - 2° of vertical for Ultra Heavy Duty masts with payloads of 800 lb. to 1,200 lb. (362.9 kg to 544.3 kg)
 - 5° of vertical for Heavy Duty masts
 - Ultra Heavy Duty Masts: Masts extended 60 ft. to 80 ft. (18.2 m to 24.4 m) can be operated on terrain having a slope up to:
 - 4° of vertical for payloads 600 lb. (272.2 kg) or less
 - 1° of verticals for payloads 600 lb. to 1,200 lb. (272.2 kg to 544.3 kg)Sail area could impact the mast deployment angle if the wind is blowing in the direction of the tilt. Consult factory.
 - Operating Temperature -20°C to 60°C (-4°F to 140°F)

Check with The Will-Burt Company's engineering team for additional wind information for customer-specific loading scenarios.

6.3.2 Extend the Mast

This section describes extending the mast. As mast tubes extend, they force water out of the weep holes. Keep personnel or sensitive equipment away from the weep hole direction while extending the mast.

6.3.2.1 Partial Extension Applications

This section describes applications using partial extension of the mast assuming the use of a hold down platform and two hold down leashes (Section 3.3.5). Note that masts with 6.75-inch base tubes only have and require one hold down leash.

For partial extension applications:

1. Install the hold down platform on top of the mast.
2. Secure a hold down leash to the hold down platform at a lug.
3. Secure a hold down leash to a guy lug on the desired mast collar. The guy lug on the desired collar should be in-line with the lug on the hold down platform.
4. Secure the second hold down leash to the hold down platform at the lug opposite the first hold down leash.

5. Secure the second hold down leash to a new guy lug on the desired mast collar. The guy lug on the desired collar should be in-line with the lug on the hold down platform. During mast extension, the sections between the connection points will be prevented from fully extending and settle once air is exhausted.

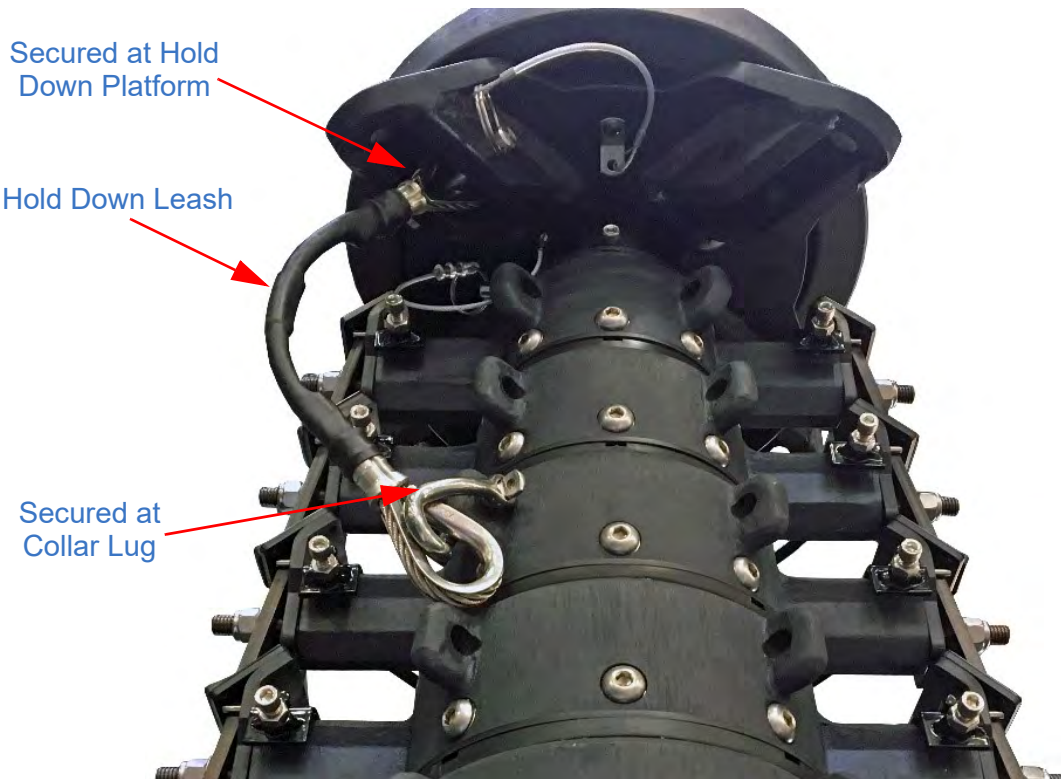

Figure 6-1 Hold Down Leash Secure in Place

With the hold down platform and hold down leashes in place, the mast can be operated with either powered operation or manual operation.

6.3.2.2 Mast Extension Procedures

To extend the mast:

1. Prepare the mast system for operation (Section 6.3.1).
2. Remove the mast top cover.
3. Secure the payload to the mast (Section 5.13).
4. If guy lines are used, attach the guy lines to the payload platform or appropriate collar lugs.
5. Prior to extending the mast, The Will-Burt Company recommends laying out any guy lines so they do not become tangled during extension (Figure 6-2).

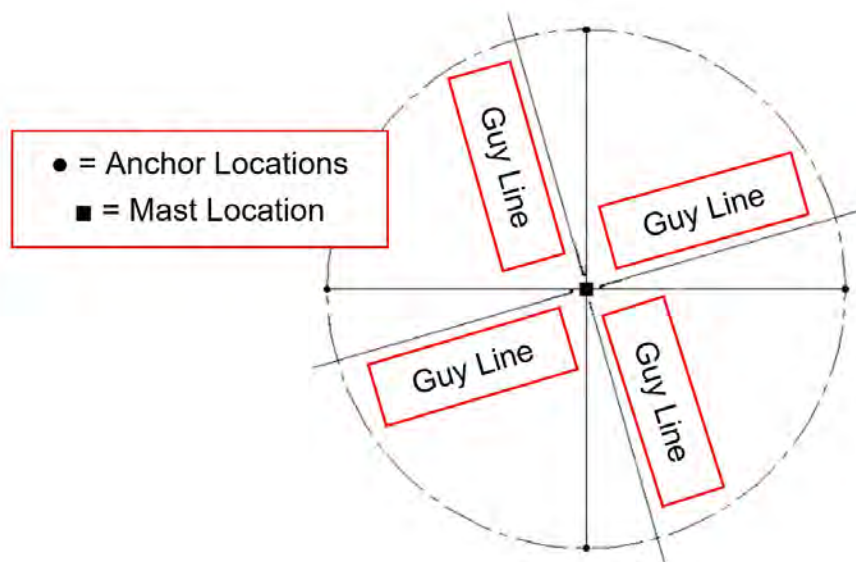

Figure 6-2 Sample of Laying Out Guy Lines (Single Level Guying Shown)

6. If guy lines are used, find the ground anchor locations and install the ground anchors.
7. Ensure the payload will have enough clearance as the mast is extended.

8. If operating the mast from the control box, select “BOX” on the control box. The “BOX/REMOTE” switch is a maintained switch and will keep its position.

If operating the mast from the HHRC, select “REMOTE” on the control box.

If operating manually (typically an emergency operation when power is not available):

- a. Ensure all electrical circuits are de-energized and properly tagged to prevent injury during operation.
 - b. Disconnect the air hose at the base of the mast.
 - c. Connect a hand pump to the base of the mast.
 - d. Use the hand pump to pressurize the mast.
 - e. Skip to Step 12.
9. Select “HOLD”. The “HOLD/EXHAUST” switch is a maintained switch and will keep its position.
 10. Select and hold “UP” to extend the mast. The “UP” function on the “UP/DOWN” switch is momentary. Continue to hold “UP” until the mast is fully extended.

Maintain visual contact throughout extension to avoid overhead obstructions and to ensure none of the cables become tangled or snag on anything. Do not exceed the maximum recommended operating pressure of 35 psi at any time.

11. When the mast is fully extended, release the “UP” switch and select “EXHAUST” to exhaust air from the mast.

12. If guy lines are used, properly secure and tension the guy lines immediately after raising the mast. All guy lines should be equally tensioned. Beginning at two locations opposite each other, gradually tension each guy line. Vertical alignment of the mast is accomplished by observing the mast perpendicularly to the two guy lines being tensioned to ensure the mast is standing straight, and is not bending too far towards one side (Figure 6-3). Adjust the appropriate guy line as necessary to keep the mast plumb vertically. Check one day after initial install. Check periodically afterwards.

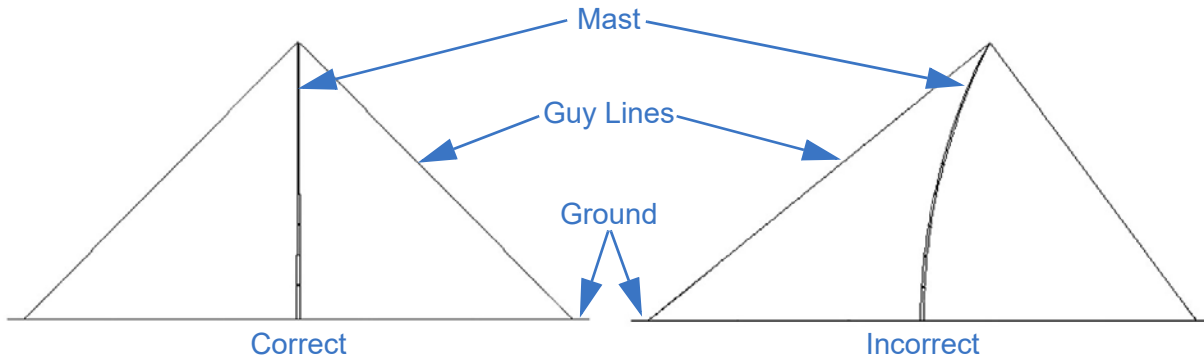

Figure 6-3 Vertically Align the Mast (Single Level Guying Shown)

13. Open the drain cock for prolonged deployment to release air pressure and allow for drainage of water which may enter the mast. The drain cock shall be opened while a locking mast is deployed and depressurized to drain water.

Note: When leaving a mast partially extended in potentially freezing conditions, follow the *Weatherizing Instructions for Pneumatic Masts* (TP-4744301).

6.3.3 Lower the Mast

To lower the mast:

1. Ensure the payload will have enough clearance when nested.
2. Close the drain cock.
3. If guy lines are used, decrease the tension on the guy lines until there is slack in the lines. Never attempt to unlock a mast collar with tension on the guy lines above it. When decreasing tension on the guy lines, begin at two locations opposite of each other and gradually decrease tension on each guy line while observing to ensure the mast is not bending too far towards one side.

Note: Do not leave mast system that requires guy lines unguyed. If the mast system has not been lowered and personnel will not be available to operate the guy lines, re-guy the mast.

4. If operating the mast from the control box, select “BOX” on the control box. The “BOX/REMOTE” switch is a maintained switch and will keep its position.

If operating the mast from the HHRC, select “REMOTE” switch on the control box.

If operating manually (typically an emergency operation when power is not available):

- a. Ensure all electrical circuits are de-energized and properly tagged to prevent injury during operation.
- b. Disconnect the air hose at the base of the mast.
- c. Connect a hand pump to the base of the base.
- d. Use the hand pump to pressurize the mast until movement is seen in the first intermediate tube. This is to lift the weight of the mast off the latching pins in the locks.
- e. Manually actuate the latch pins using a screwdriver. The latch pins should move freely with proper pressure. If the latch pins do not easily move, do not force them to actuate. Pressurize the mast until the latch pins can be easily moved.

Note: Do not over-pressurize the mast as this will cause the locks to jam. In this instance, release pressure until the latch pins can be easily moved.

- f. With the latch pins actuated, continue to depressurize the mast. Once the first intermediate tube begins to descend, the latch pins can be released. Continue to depressurize the mast until it is fully retracted.
 - g. Skip to Step 9.
5. Select “HOLD”. The “HOLD/EXHAUST” switch is a maintained switch and will keep its position.

6. Select “DOWN” to lower the mast. The “DOWN” function on the “UP/DOWN” switch is maintained. Air will be applied to the mast (35 psi) to lift the weight off the latch pins and to the locks (15 psi) to unlock the latch pins. When the locks are unlocked, the “UNLOCKED” LED will illuminate. The mast will then depressurize and lower. Continue to hold “DOWN” until the mast is fully retracted.

For systems using guy lines, gently pull the guy lines away from the mast as it is lowered. Keeping the guy lines organized will facilitate coiling the guy lines for storage or preparing the guy lines for the next mast extension.

7. Periodically open the drain cock when exhausting the mast to drain off any accumulated water.
8. Once the mast is fully retracted, select the middle position with the “UP/DOWN” switch.
9. If guy lines are used, remove the guy lines.
10. Remove the payload.
11. Fit the mast top cover over the mast and secure it in place to protect the mast from water and debris.
12. Open the drain cock when the mast is not in use. If the drain cock is not left open when not in use, it can collect condensation and fill up with water. This water can freeze, which causes the mast to not function correctly or break.
13. The Will-Burt Company recommends disconnecting power from the control box when not in use to prevent inadvertent operation of the mast. This is particularly important during transportation.

Note: The operator should always visually confirm the mast is entirely retracted before moving the vehicle. For further information on transporting the mast system, see Section 7.

6.4 Emergency Retraction Procedure

This section defines the emergency retraction procedure for the Pneumatic Mast with Remote Locking System where there is:

- No power going to the mast system
- No air flow going to the mast
- No air pressure in the mast

Note: Emergency retraction could cause damage to the locking pins, latch panels and/or tube keys. Due to this risk, a certified service technician is required to inspect the mast after executing the emergency retraction procedure. Contact The Will-Burt Company for further assistance.

To cause the mast to retract in situations with no power, no air flow, or no air pressure:

1. Using a wrench, loosen nuts from the locking pins on the base tube collar until a minimum .125 in (3.18 mm) gap between the washers and latch levers is achieved.
2. Place .125 in (3.18 mm) shims/spacers between washers and latch levers.
3. Using a wrench, tighten the nuts on the locking pins. This will draw out the locking pins from the latch panel, which will then unlock the adjacent tube section.

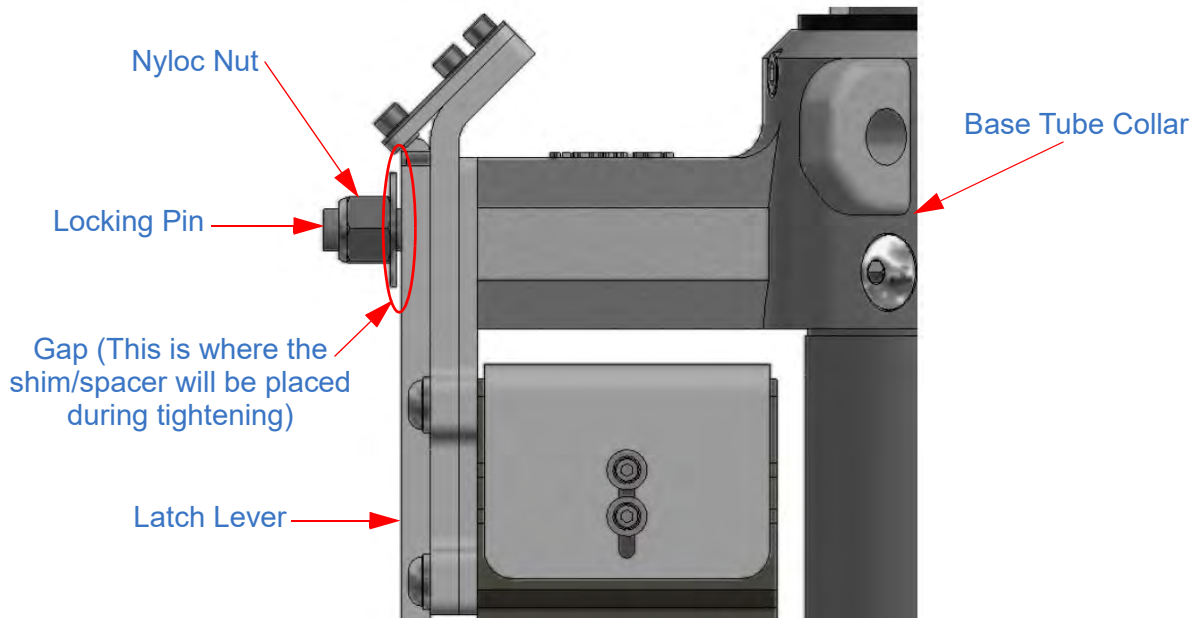

Figure 6-4 Tighten Nuts Until Upper Tubes Collapse

Doing this should cause the top tubes to collapse abruptly, but the rest of the tubes should retract more slowly at a more controlled pace.

This page intentionally left blank.

7 Transportation

Before transporting the mast system, the mast system needs to be secured. The exact procedures for transportation will vary based on the mast system configuration. The process described in this manual represents a possible method of transporting the mast. Depending on the environment and equipment available, other methods may work better. Use the best and safest method for your circumstances.

7.1 General Transportation

To prepare the mast system for transportation:

1. Ensure the mast is fully nested (Section 6.3.1). Do not transport the mast system with the mast and payload extended. Always visually confirm the mast is fully retracted before moving the mast.
2. Disconnect the air supply and open the drain cock while the mast is not in use to eliminate the possibility of inadvertent mast extension.
3. If desired, remove and secure the payload. The payload should be removed, and the mast top cover fitted over the mast and secured in place.

Note: If transporting the mast in the horizontal position, the mast sections must be secured to prevent them from accidentally extending as the mast sections are unlocked when nested. The Will-Burt Company recommends the use of a hold down platform with two hold down leashes (Section 6.3.2.2) as follows:

- a. Install the hold down platform on top of the mast.
- b. Secure a hold down leash to the hold down platform at a lug.
- c. Secure a hold down leash to the base tube collar at the lug in-line with the lug on the hold down platform.
- d. Secure the second hold down leash to the hold down platform at the lug opposite the first hold down leash.
- e. Secure the second hold down leash to the base tube collar in-line with the lug on the hold down platform.

Note: Masts with 6.75-inch base tubes only have and require one hold down leash.

4. If necessary, secure any additional components in the system. Note that it is the responsibility of the customer to properly secure the payload for transportation.

Note: The operator should always visually confirm the mast is entirely retracted before moving the vehicle.

7.2 Shipping

When shipping the mast system, The Will-Burt Company recommends shipping the mast in the original shipping crate. If the original shipping crate is not available, contact The Will-Burt Company to order a replacement.

When shipping:

1. As necessary, remove the payload.
2. As necessary, prepare the mast system for transportation (Section 7.1).
3. As necessary, uninstall the mast system from the mounting structure (Section 5).
4. Secure the mast system in the shipping crate:
 - a. Carefully position the mast in the crate.
 - b. When shipping by air, ensure the air inlet port is open.
 - c. Secure the block at the top of the mast to prevent the mast from shifting in the shipping crate during transportation.
 - d. Secure the top half of the wooden mast saddles.
 - e. As necessary, carefully pack any additional components in the shipping crate.
 - f. Secure the lid on the shipping crate.

8 Maintenance and Adjustments

This section describes maintenance and adjustment procedures required to keep the mast system operational. Use care to understand and follow all precautions listed in the Safety Summary in Section 1 while performing these procedures. If the system does not perform as required, see Section 9.

Disconnect power to any devices mounted to the mast and pneumatic systems with lock-out tag-out procedures as appropriate before performing mast maintenance.

8.1 Pre-Maintenance Check

Before performing maintenance procedures, ensure:

- All operators read and understand the entire maintenance procedure and are properly trained.
- The payload is removed prior to performing maintenance on the system.
- The system is level and secure.

8.2 Maintenance Equipment

Table 8-1 lists recommended equipment for maintenance.

Table 8-1 Equipment Recommended for Maintenance

Recommended Equipment*		
Personal Protective		
Safety Glasses	Work Gloves	Safety Shoes
Hard Hat or Helmet	Hearing Protection	Nitrile or Vinyl Gloves
Hand Tools		
Chisel	Drill	File
Flat Punch	Hammer	Hex Wrenches
Screwdrivers	Measuring Tape	Level
Sockets	Torque Wrenches	Utility Knife
Wrenches	Rubber Mallet	Saw
Plumb-Bob		
Equipment		
Compressed Air Supply	Hoist	Sling / Strap
Ratchet Straps	Saw Horses or Similar Supports	
Expendables		
Acetone, Alcohol, or other solvent	Pipe Thread Sealant or PTFE Tape	Rags (Clean and Dry)
Loctite® 263 (Red)	Loctite® 380 Black Max	Loctite® 495 Instant Adhesive
Silicone Sealant	Non-Abrasive Cleaners (Soap and Water)	Pneumatic Mast Grease Kit (P/N: 5448701)
<p>* Note:</p> <ul style="list-style-type: none"> • Depending on the local, regional, and national standards and codes of practice, and the environment, additional personal protective equipment may be necessary. • When disposing of any disposables or components, do so according to any applicable local, regional, and national standards and codes of practice. 		

8.3 Replacement Parts

To order spare or replacement parts, always refer to the mast model number and serial number. The model number, serial number, and additional information is engraved on the mast identification plate (Section 3.3.1.6). Throughout this manual, “P/N” followed by a number represents the part number for that component. To order spare parts, or for the part numbers for additional components, contact The Will-Burt Company.

8.4 Periodic Maintenance

This section describes the systematic care and inspection of equipment to keep it in safe operating condition and to prevent breakdowns. If the system does not perform as required, see Section 9 for troubleshooting. If anything looks wrong and cannot be diagnosed and/or fixed, contact The Will-Burt Company. Table 8-2 provides a schedule of periodic inspections and procedures required to keep the mast system in safe operating condition.

Table 8-2 Periodic Inspections

Frequency	Inspection	Action
As Needed; In salt water or sandy environments clean the mast every 3 months.	Inspect to ensure the mast system is kept clean and free from foreign material. Dirt, grease, oil, sand and debris may cover up a serious problem.	Clean the mast per the procedure in section 8.4.
During Operation	Inspect for damage during operation.	If damage is apparent, do not use the mast, and have it serviced prior to use.
Monthly	Visually observe tube motion during extension and retraction to ensure the tubes move smoothly and do not cause excessive impact loads when each tube fully extends or retracts.	Cease all mast use and contact The Will-Burt Company Service immediately.
Monthly	Inspect for any damage to electric cables and pneumatic tubes.	Replace cables/tubes as required.
Monthly	Inspect for any damage to hoses.	Replace hoses as required.
Monthly	Inspect all collar bolts in all tube sections to ensure they are not backing out.	Add Loctite™ 263 and re-tighten to 60-65 in.-lb. installation torque if they are loose.
Monthly	Test the magnetic warning kit to ensure the vehicle driver is warned or prevented from driving with the mast deployed.	Repair the magnetic warning kit if not functioning properly.

Table 8-2 Periodic Inspections

Frequency	Inspection	Action
Monthly	Inspect all hardware to ensure fasteners are not damaged, loosening, backing out or missing. Take special note of hardware keeping the payload mounted, mast collar bolts, and hardware used to mount the mast to the support structure.	Tighten or replace any loose, damaged or missing fasteners.
Every 6 Months (3 months in salt water environment)	If the mast remains idle for long periods of time, operate the mast to full extension at least once every six months (3 months in salt water environment).	Exercise mast.
As every use	Inspect to ensure the drain cock is left open when the mast is not in use to drain water from the mast.	Open the drain cock.
In potentially freezing conditions.	Ensure the mast is weatherized (Section 8.4.2).	Weatherize the mast (Section 8.4.2)

8.4.1 Mast Cleaning and Lubrication

The Will-Burt Company's Pneumatic Masts come from the factory pre-lubricated. Under normal operating conditions, the grease applied at the factory is sufficient for five years and no scheduled maintenance is required. In extremely harsh environmental conditions, maintenance of the mast may be required.

An optional mast lubricant (P/N: 900600) may be added to ensure smooth operation and prolong the useful life of the mast in harsh environmental conditions. The mast lubricant is a blue-colored mineral oil specifically designed for telescoping masts and their operating environment. Mast lubricant comes in a 16 oz. capped plastic bottle.

The Will-Burt Company recommends removing the payload before performing the mast cleaning and lubrication process.

Signs cleaning and lubrication might be needed can be:

- A noticeable gritty film on the exterior surfaces of the tubes
- Erratic extension or retraction of the mast
- Noisy operation of the mast
- Sticking of one or more tubes when mast is extending or retracting

To clean the mast:

1. Secure the hold down leashes so that only the top tube can extend. Note: Masts with 6.75-inch base tubes only have and require one hold down leash.
2. Slowly pressurize the mast just enough to extend the top tube.
3. Dampen a rag with a non-abrasive cleaner or solvent such as lacquer thinner to wipe down the extended tube. Do not allow the cleaning fluid or solvent to run down inside the collar.
4. If not lubricating the mast, skip to Step 7.

If lubricating the mast (optional, but helpful in extremely harsh conditions):

- a. Inject approximately ½ oz. of mast lubricant (P/N: 900600) into the weep hole of the exposed tube. The weep holes are located between 1 and 3 feet (30 and 91 cm) below the collar on each tube except the top tube. Do not lubricate the exterior of the mast. This attracts dust and contaminants from the air.
 - b. Repeat 3, 5, and 6 for each of the remaining tubes. The larger diameter tubes should be injected with approximately 1 oz. of lubricant.
 - c. Lower the mast completely. Allow several minutes for the lubricant to settle and spread around the wear ring and seal at the bottom of each tube.
 - d. Extend the mast again, one tube at a time from smallest to largest. Wipe off any excess lubricant that flows out of the weep holes.
5. Depressurize the mast to lower the extended tube.
 6. Reconnect the hold down leashes so that the next tube can extend when the mast is pressurized.
 7. Repeat this procedure for each tube from smallest to largest.

8.4.2 Weatherizing

For weatherizing your mast in extremely harsh environmental conditions, The Will-Burt Company recommends following the *Weatherizing Instructions for Pneumatic Masts* (TP-4744301). See www.willburt.com for these instructions. These instructions assume the use of the Pneumatic Mast Antifreeze Kit (P/N: 4725801).

The Pneumatic Mast Antifreeze Kit includes:

- (2) Flush Caution Labels (P/N: 4770001)
- (1) Gallon Will-Burt Non-Toxic Pneumatic Mast Antifreeze (P/N: 4735801)
- (1) Will-Burt Non-Toxic Pneumatic Mast Antifreeze Application Bottle (P/N: 4726101)
- (1) Will-Burt Antifreeze MSDS (P/N: 4746201)
- (1) Will-Burt Lubricant, MSDS, and Service Sheet (P/N: 900600)
- The Weatherizing Instructions for the Locking and Non-Locking Pneumatic Masts (TP-4744301)



Figure 8-1 Application Bottle (Left) and Gallon of Will-Burt Non-Toxic Remote Locking System Antifreeze (Right)

Will-Burt Non-Toxic Pneumatic Mast Antifreeze (P/N: 473801) can also be purchased by the gallon.

8.5 Corrective Maintenance

This section describes corrective maintenance for the system. Depending on the mast system configuration and the conditions of the mast system, all corrective maintenance procedures may not be required. Follow the appropriate instructions for your mast system.

Prior to performing corrective maintenance, remove the:

- Payload from the mast
- Mast from the mounting structure

For reference information on tube diameters and collar dimensions, see Section 4.

8.5.1 Special Procedure: Reed Switch Adjustment

When the base tube locks are unlocked (air cylinders actuated), the light on each reed switch should illuminate. When the base tube locks are locked (air cylinders retracted), the lights on the reed switches should not illuminate. If a light does not illuminate when the locks are unlocked or does illuminate when the locks are locked, the reed switch needs adjusted.

To adjust a reed switch:

1. Remove the air cylinder cover to gain access to the reed switch located in the T-slot on the air cylinder body.
2. Pressurize the mast so that the locks unlock.
3. Loosen the screw securing the reed switch that needs adjusted.
4. Slide the reed switch outwards towards the latch lever, then slowly slide it inwards towards the base tube until the light illuminates. Stop moving the reed switch as soon as it illuminates.
5. Secure the reed switch into place by tightening the screw on the reed switch. The screws are friction locks. Do not overtighten the screws.
6. If necessary, repeat this procedure for the second reed switch.

8.5.2 Replace Collar Inserts

This section describes replacement of collar inserts. Some collars have collar bearing strips instead. For information on replacing collar bearing strips, see Section 8.5.5.

Inspect the collar insert and the machined keyways in it for wear. If the keyways of the collar are badly worn (elongated), the collar insert should be replaced.

To replace the collar inserts:

1. Using a knife, carefully remove the flat rubber external bumper that is glued to the top of the collar. If the collar is equipped with an external wiper instead of an external bumper, remove the wiper and set aside as this will be reinstalled later.
2. Remove the (4) 1/4-28 socket head cap screws from the collar with a hex wrench. This allows the collar insert to be removed from the collar.
3. Carefully tap around the top edge of the collar insert with a hammer and flat punch or chisel to drive the collar insert out the bottom of the collar. The collar insert can only be removed from the bottom of the collar.
4. Clean the collar.
5. Install the new collar insert into the collar. Make sure to align the holes in the collar insert with the holes in the collar. It may be necessary to gently tap the collar insert into the collar. Use care not to damage the collar insert.
6. Apply adhesive, such as Loctite® 495 Instant Adhesive, to the ends of the 1/4-28 socket head cap screws and fasten the collar insert to the collar.
7. Replace the external bumper (Section 8.5.3) or external wiper (Section 8.5.4).
8. Before reassembling the mast, slide each collar over its mating tube. If the collar does not slide freely over the tube, it will be necessary to sand high spots on the insert to fit. The high spots will appear as shiny or discolored marks on the inside diameter of the collar insert.
9. Clean the collars to remove debris before reassembling the mast (Figure 8-2).

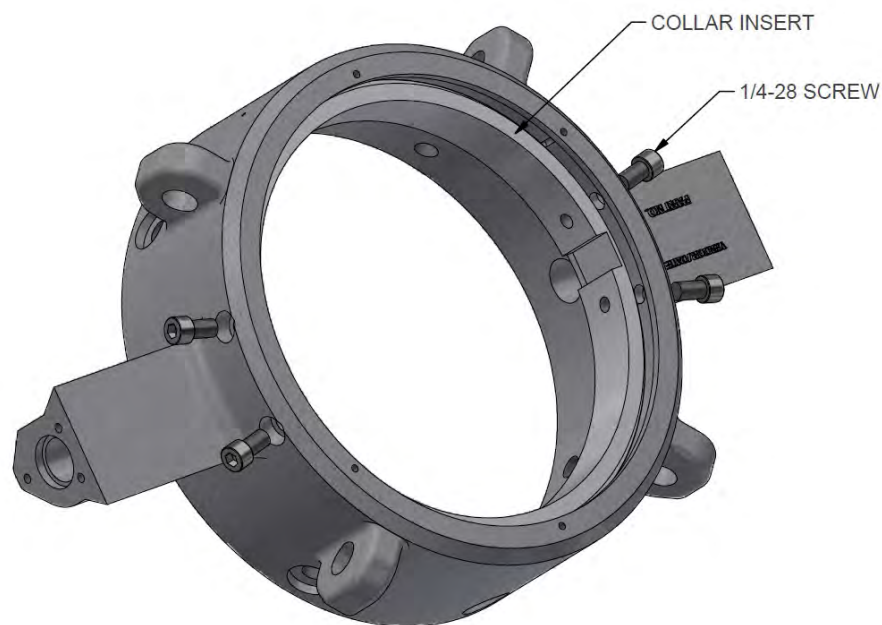

Figure 8-2 Replacing Collar Inserts

8.5.3 Replace External Bumpers

The external bumper is a flat rubber ring cemented to the top of each mast collar. Check the condition and the adhesion of each external bumper. If the external bumpers become loose, they can usually be reused unless they have been damaged.

To replace the external bumpers:

1. Remove the old external bumper.
2. Use acetone to clean off any old adhesive from the collar. Clean the replacement external bumper with acetone. Allow it to dry thoroughly.
3. At room temperature, apply a light bead of Loctite® 380 Black Max or equivalent around the top of the collar. Follow the manufacturer's instructions.
4. Place the external bumper on the collar and align the inside diameter edges. Hold pressure on the external bumper and collar using a uniform weight for at least 90 seconds.
5. Using a razor knife, notch out keyways in the external bumper to match those in the collar (Figure 8-3).

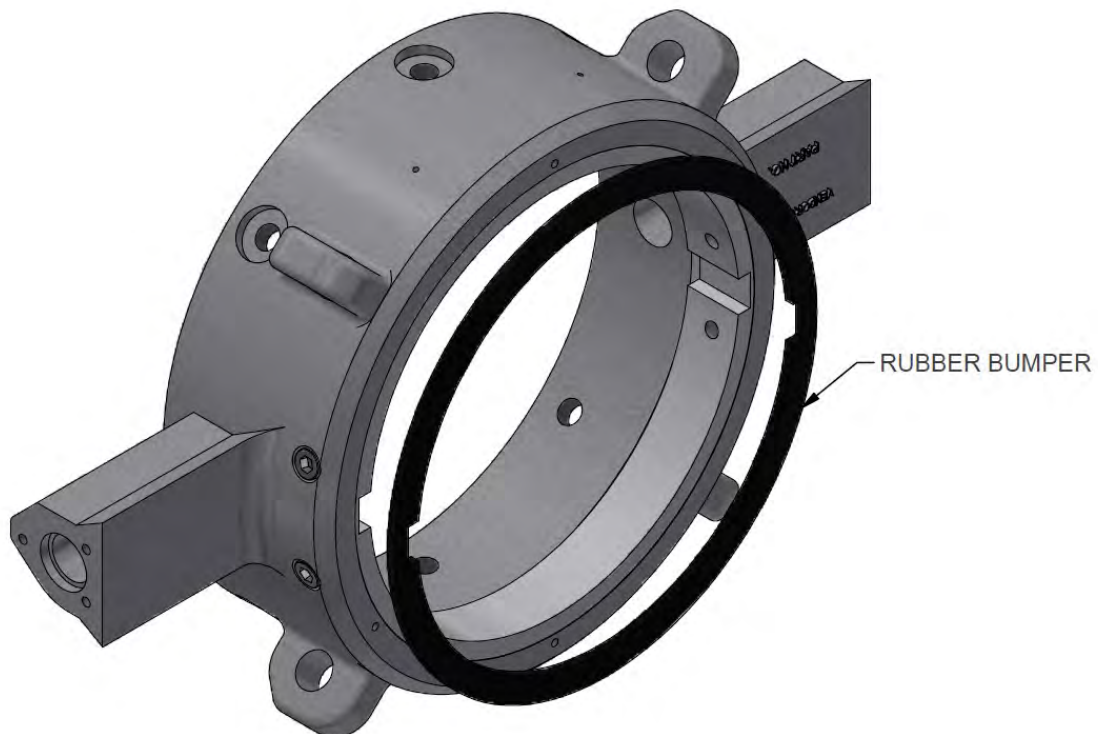

Figure 8-3 Replacing External Bumpers

8.5.4 Replace External Wipers

The external wiper is a rubber wiper fixed to the top of each collar which limits dust/debris ingress in between mast tube sections. Check the condition of each external wiper, specifically along the wiper lip, of each collar.

To replace the external wipers:

1. Remove the old external wiper and wiper flange by unscrewing the flat head cap screws along the top surface of the collar. Set aside the wiper flange as these will be re-used. The #6-32x1/2" may need to be replaced.
2. Use acetone to clean off the top of the collar. Clean the replacement external wiper with acetone as well. Allow to dry thoroughly.
3. Apply Loctite 243 to the flat head cap screws and fix the new external wiper and the wiper flange to the top of the collar.
4. Ensure the wiper bumper fits snug around the adjacent after the collar is re-installed onto the mast (Figure 8-4).

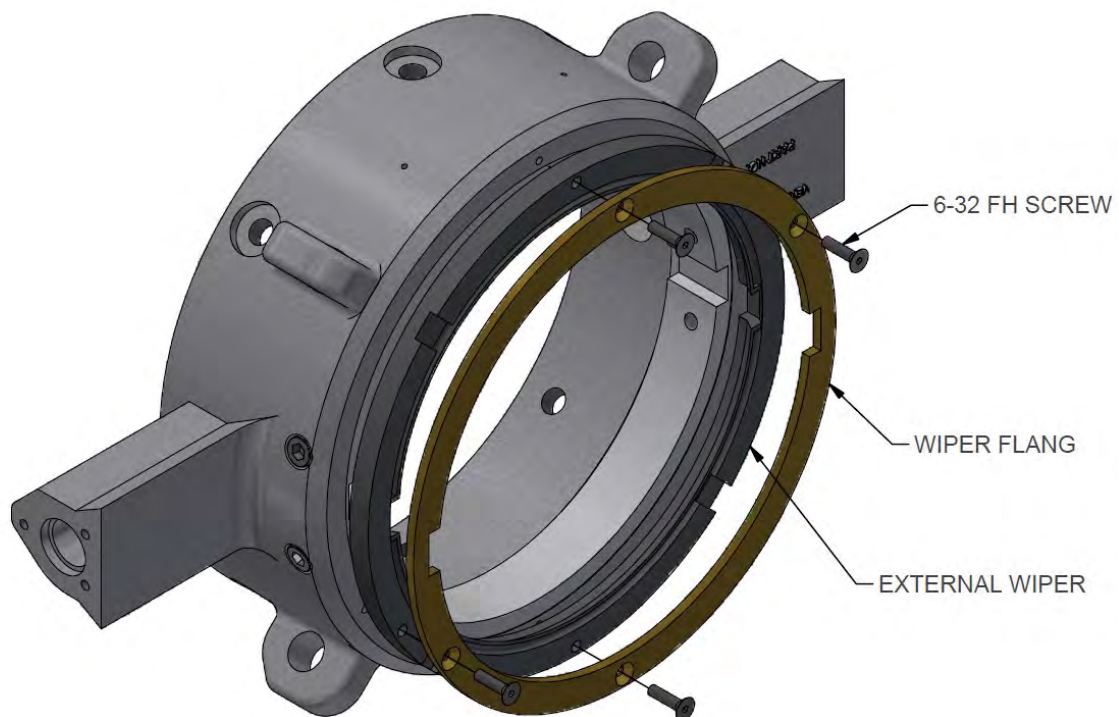

Figure 8-4 Replacing External Wipers

8.5.5 Ultra Heavy Duty Bearing Strips

The Ultra Heavy Duty mast has two types of locking collars. The previous procedure (Section 8.5.2) explains the process for the bearing strips for 11.25, 10.0, 9.12, and 8.25 collars. Below describes the process for bearing strips for 13.5 and 12.375 collars.

To replace the bearing strips for 13.5 and 12.375 collars (Figure 8-5):

1. Loosen the eight 5/16-18x0.75 bolts securing the collar together.
2. Remove and discard the external bumper.
3. Make a note of the orientation of the collar retainer and remove the collar adjustment retainer.
4. Lift out and discard the collar bearing strips.
5. Do not remove the collar push plates or set screws.
6. As necessary, clean the collar.
7. Insert the new collar bearing strips.
8. Reposition the collar adjustment retainer making sure to orient it in the same manner as it was originally secured. Apply Loctite[®] 243 to the hardware and torque to 75 to 85 in.-lb.

Note: Ensure the bolts engage the holes in the locking collar and are properly secured. If the bolts are not secured, the mast can separate during extension.

9. Clean a new external bumper.
10. Apply Loctite 380 Black Max or equivalent to the external bumper and properly align it to the collar adjustment retainer. As necessary, cut the external bumper flush around the key slots as required.
11. Before reassembling the mast, slide each collar over its mating tube. If the collar does not slide freely over the tube, it will be necessary to sand high spots on the bearing strip to fit. The high spots will be evident by shiny or gray marks on the white bearing strip.

12. Wipe the collars clean before reassembling the mast.

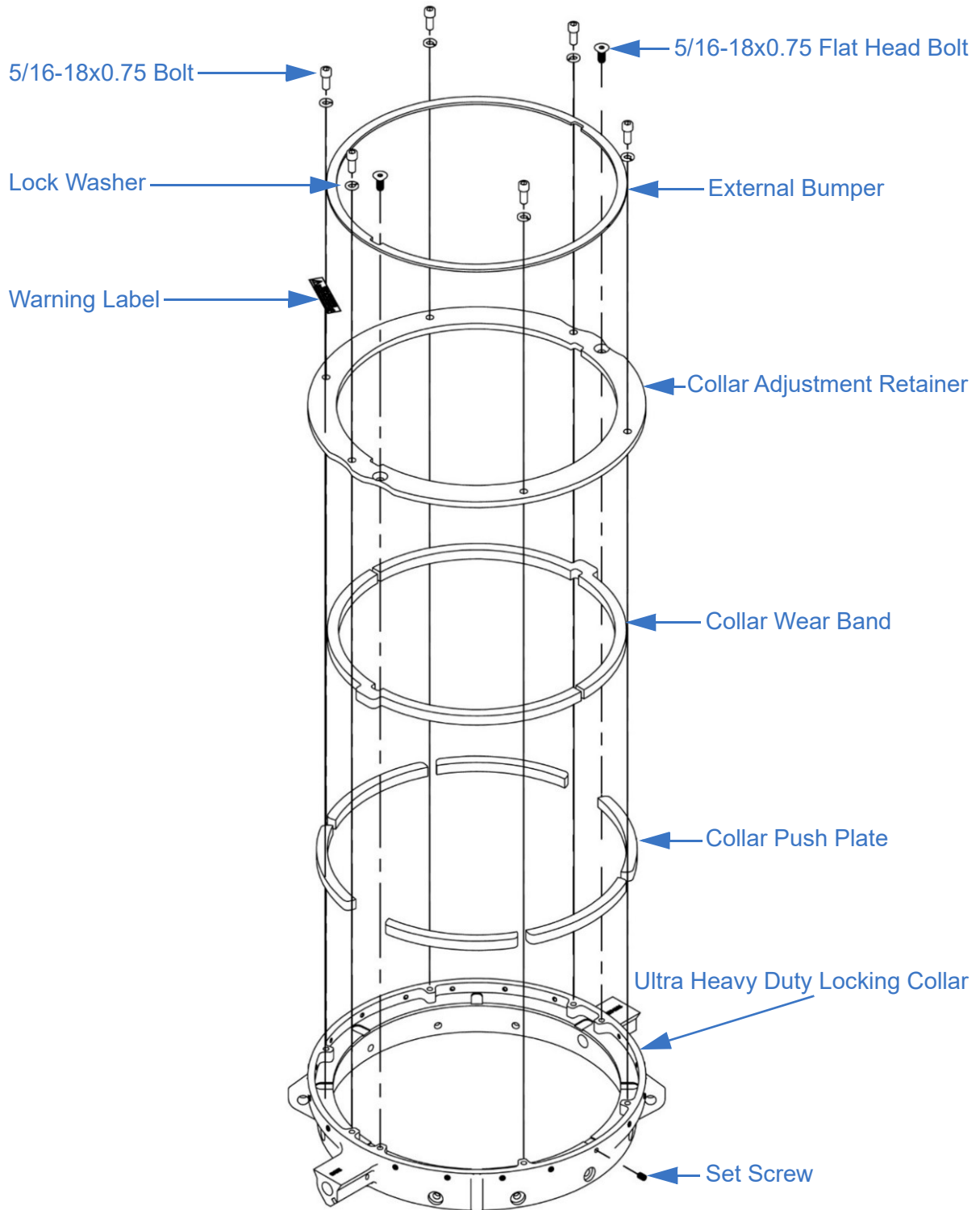

Figure 8-5 Super Heavy Duty 13.5 and 12.375 Locking Collars

8.5.6 Ultra Heavy Duty Collar Adjustment

Before making any adjustment to the collars, visually inspect (with the mast in the vertical position) that the Ultra Heavy Duty (UHD) collars (if equipped) are properly centering the intermediate tube (this is a factory setting). The space pointed to by the red arrows needs to be consistent all the way around the tube. When not properly adjusted, it's possible that the latch pins will not engage latch plate properly. Contact The Will-Burt Company for more information.



Figure 8-6 Ensure Collars Consistently Center the Intermediate Tube

If the tubes are not properly centered in the collars, the following procedure must be followed:

1. The UHD collars should only be adjusted to fit the 12.375" and 11.188" tubes when the mast is secured in a vertical position with the payload removed. The mast must be partially extended for the adjustments to be properly made. Any collars above the 12.375" collar should be held together with a The Will-Burt Company Hold-Down Leash.

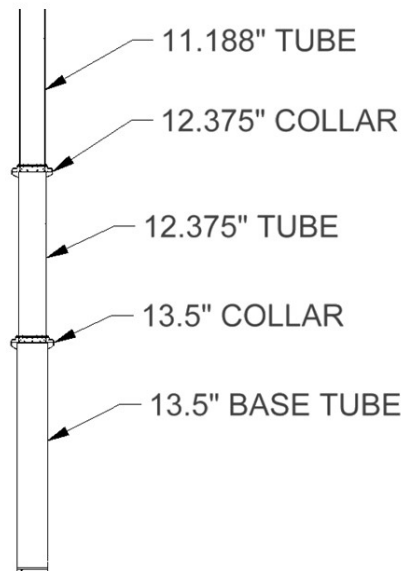

Figure 8-7 Partially Extend Mast

2. Begin extending the mast. Stop the supply of air just before the 12.375" tube section begins to rise (the 11.188" tube should be fully extended). Back the set screws out one at a time and apply Loctite 243 (or other equivalent thread locker) to the threads. Then, tighten the set screws around the perimeter of the 12.375" collar in a star pattern until the 11.188" tube is visually centered in the collar and the collar bearings are in contact with the entire circumference of the tube (this may be difficult to see due to part variation). When finished, the set screws should be relatively flush with collar surface.



Figure 8-8 Set Screws Flush with Collar Surface

3. Supply air pressure to the mast to fully extend the 12.375" tube, then halt the flow of air. Back the set screws out one at a time and apply Loctite 243 (or other equivalent thread locker) to the threads. Then, tighten the set screws around the perimeter of the 13.5" collar in a star pattern until the 12.375" tube is visually centered in the collar and the collar bearings are in contact with the entire circumference of the tube (this may be difficult to see due to part variation). When finished, the set screws should be relatively flush with collar surface.
4. Retract the mast to the fully nested position. Apply a small amount of pressure (<10 psi) and observe the extension of the 12.375" and 11.188" tubes. If any binding is observed, back off the set screws ¼ turn in the area that binding is seen. Repeat this step until no binding is observed and the tubes are still visually centered within the UHD collars.
5. Retract the mast to the fully nested position. The payload can then be reattached.

8.6 Collar Setup

The mast collars should not need adjusted or set up unless during maintenance or after the Emergency Retraction Procedure was performed. Be sure to read and understand the entire mast collar setup procedure and the Safety Summary (Section 1) before beginning the procedure. Use care to follow all precautions while setting up the mast collars.

8.6.1 Base Tube Collar Setup

To set up the base tube collar:

1. All collars should be fixed to mast tube sections and the mast secured vertically and ready to operate. If not, see Section 8.5.5.
2. Pre-assemble the pin, spring, thrust bearing and spacer plate to the base tube guide plate assembly. The slot on the guide plate assembly is cut in such a way that the pin should always be installed in the proper orientation.

Note: The Ultra Heavy Duty mast does NOT use a spacer plate.

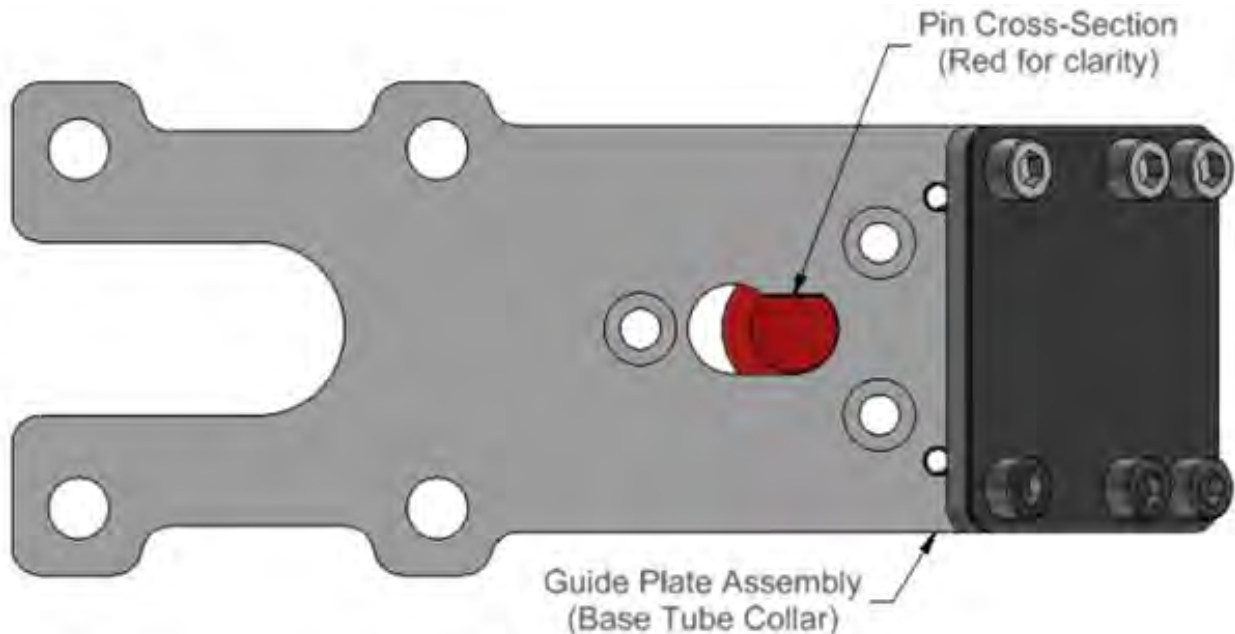

Figure 8-9 Preassemble Components to Base Tube Guide Plate Assembly

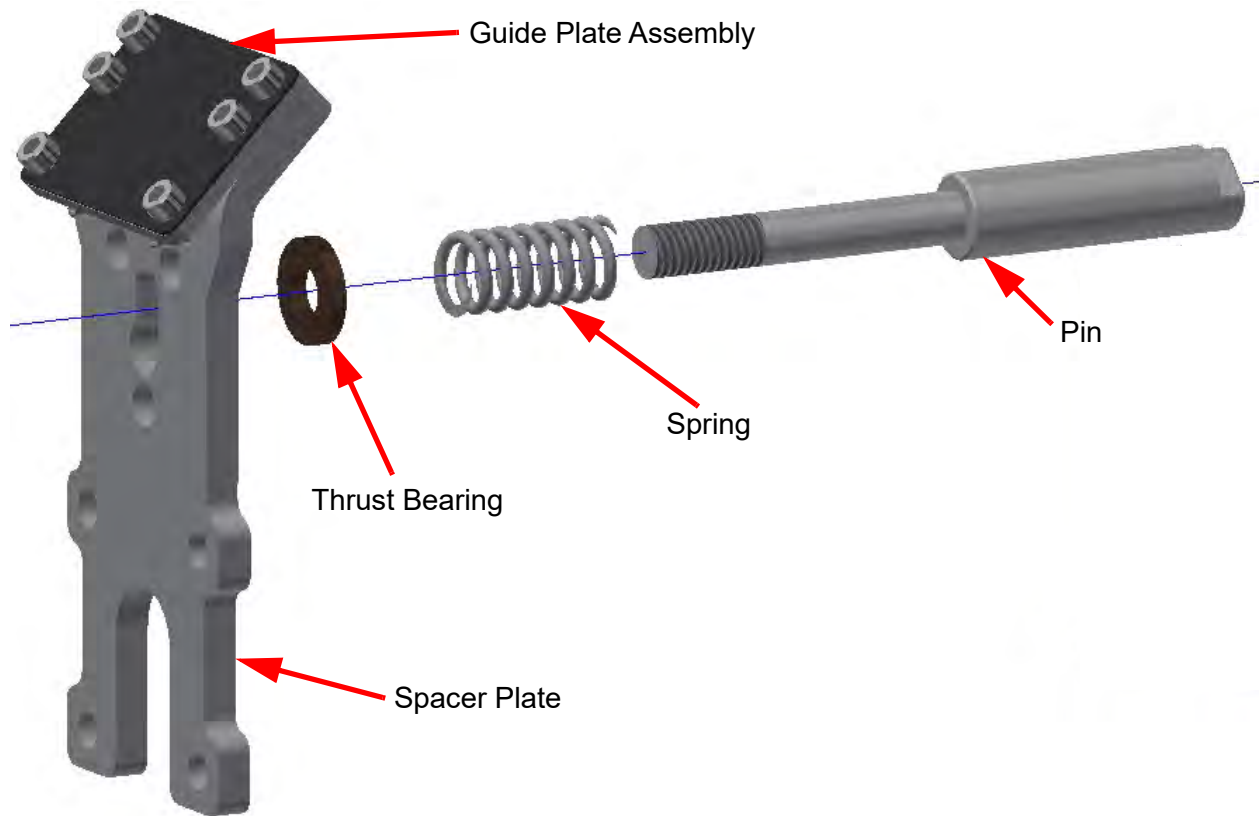

Figure 8-10 Assemble Components

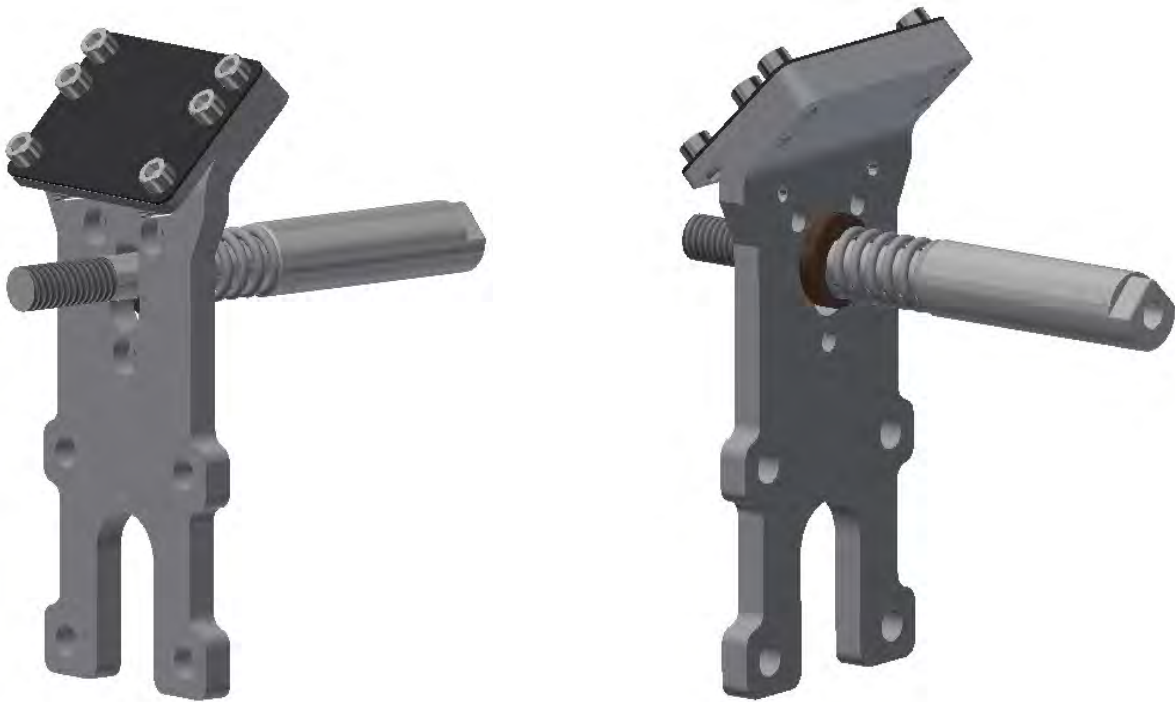

Figure 8-11 Front and Back Assembled Views

3. Apply blue Loctite 243 or equal to threaded holes of the base tube collar (Figure 8-12).
4. Mount the base tube guide plate assembly, pin, spring, spacer plate and thrust bearing to the base tube collar using (3) #8 socket head cap screws.
5. Repeat steps 3 and 4 for both sides of the collar.

Notes:

- Base tube collars with spacer plates get longer #8 cap screws compared to collars on intermediate tubes.
- You should feel resistance from the spring compressing when fastening back plate to collar.

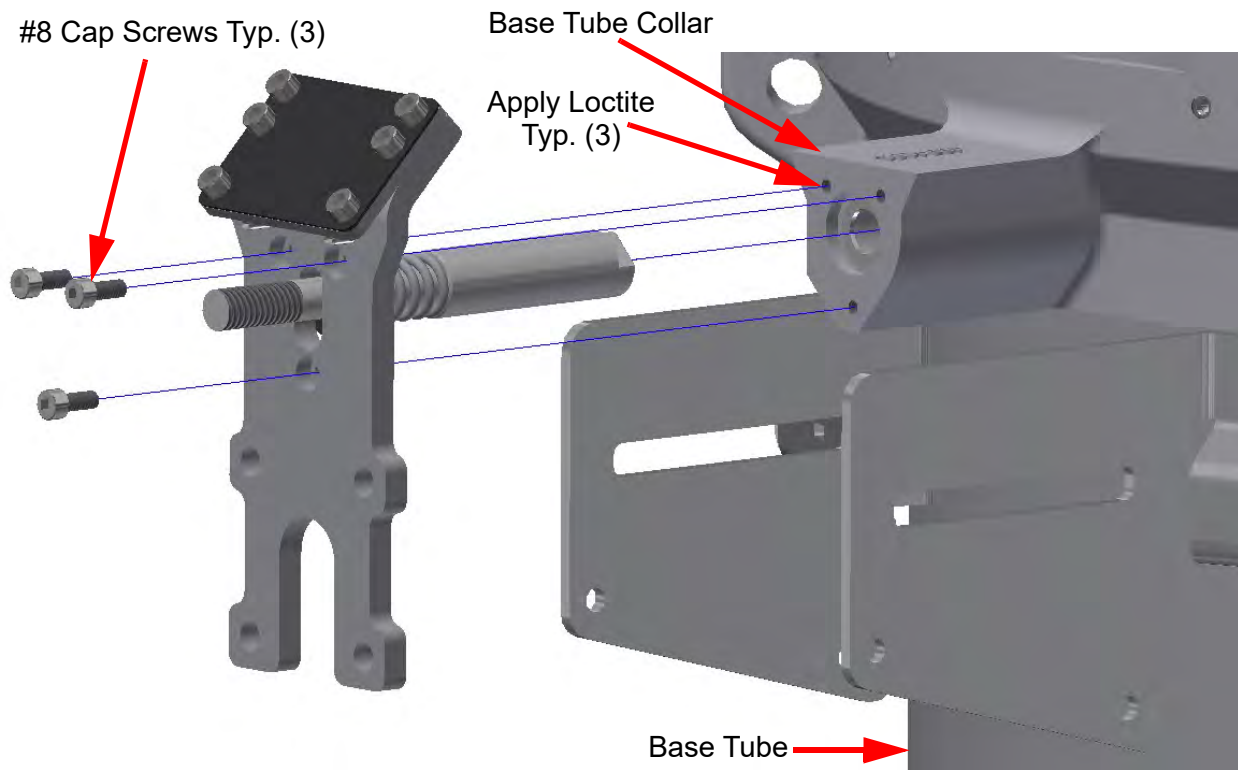

Figure 8-12 Assemble Components

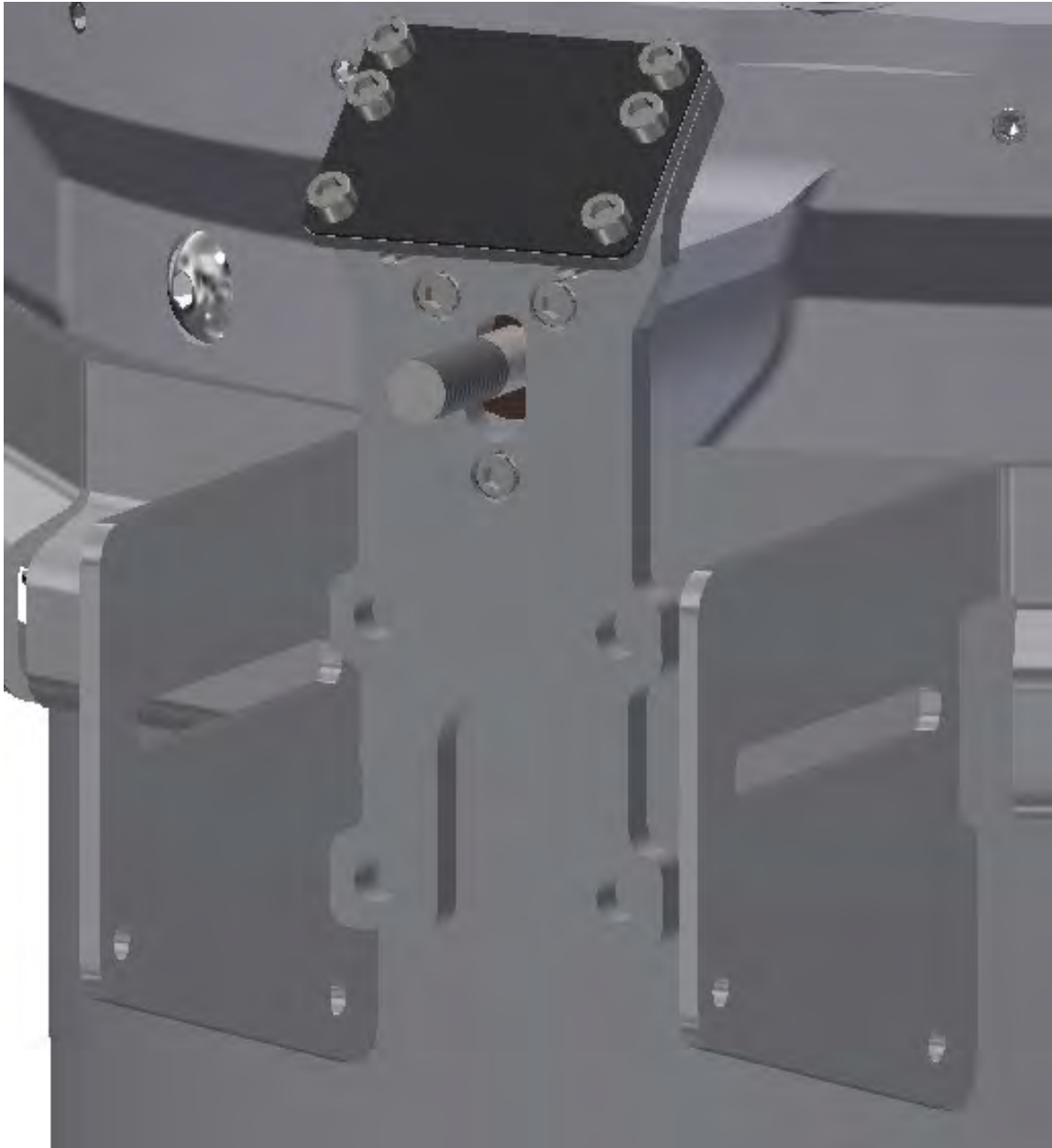

Figure 8-13 Assembled View

6. Apply blue Loctite 243 or equal to button head cap screws as shown in Figure 8-14.
7. Mount air cylinder assembly to base tube guide plate assembly using (4) button head cap screws and lock washers.
8. Repeat steps 6 and 7 for both sides of the collar.

Note: There is a difference between the left and right air cylinder assembly. The image below displays the FRONT of the mast.

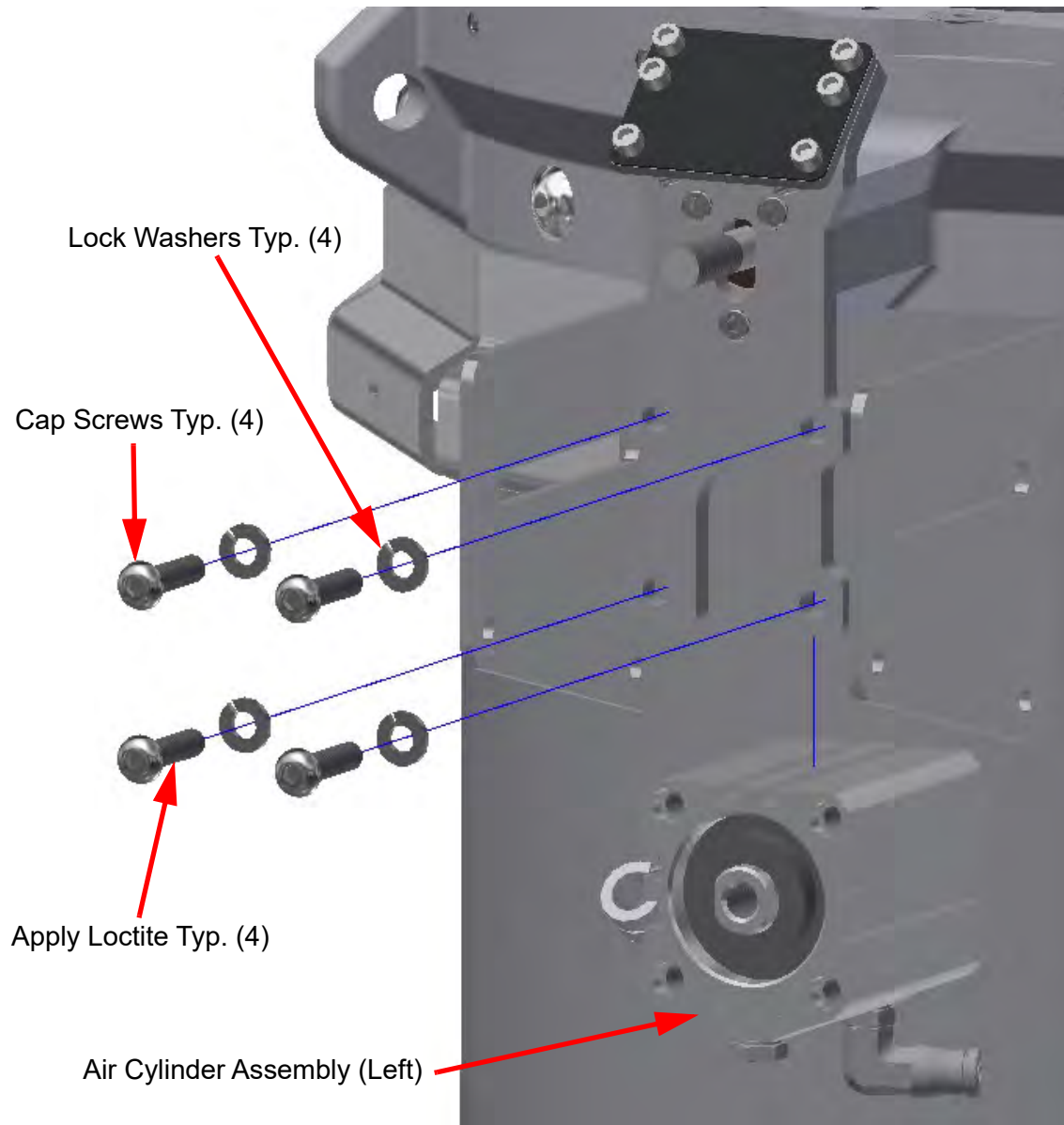

Figure 8-14 Assemble Components

9. Apply Loctite 243 or equal to button head cap screws (Figure 8-15).
10. Mount the bottom of the hose guard to the assembly using the button head cap screws and nuts (Figure 8-15).

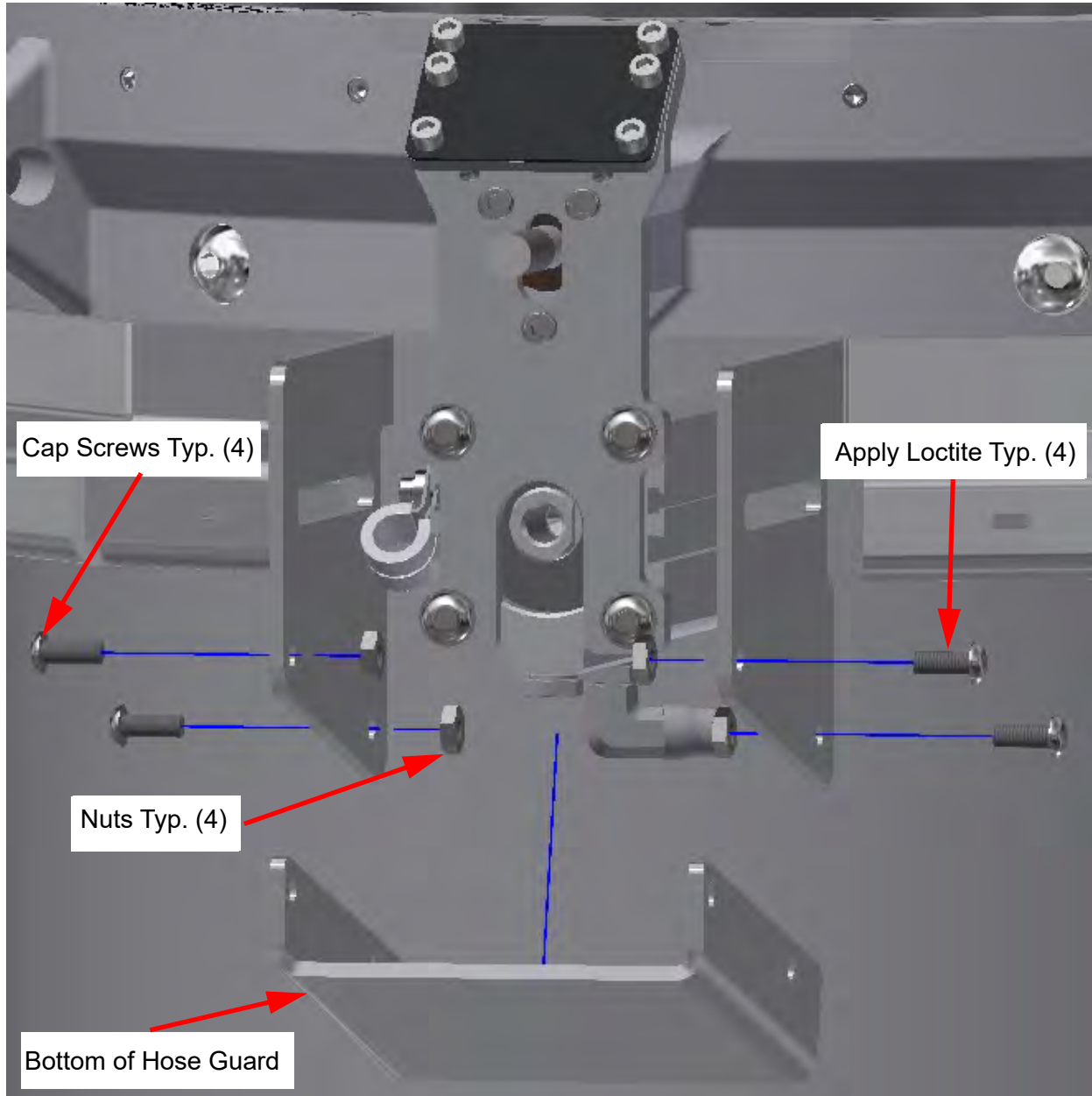

Figure 8-15 Assemble Bottom of the Hose Guard

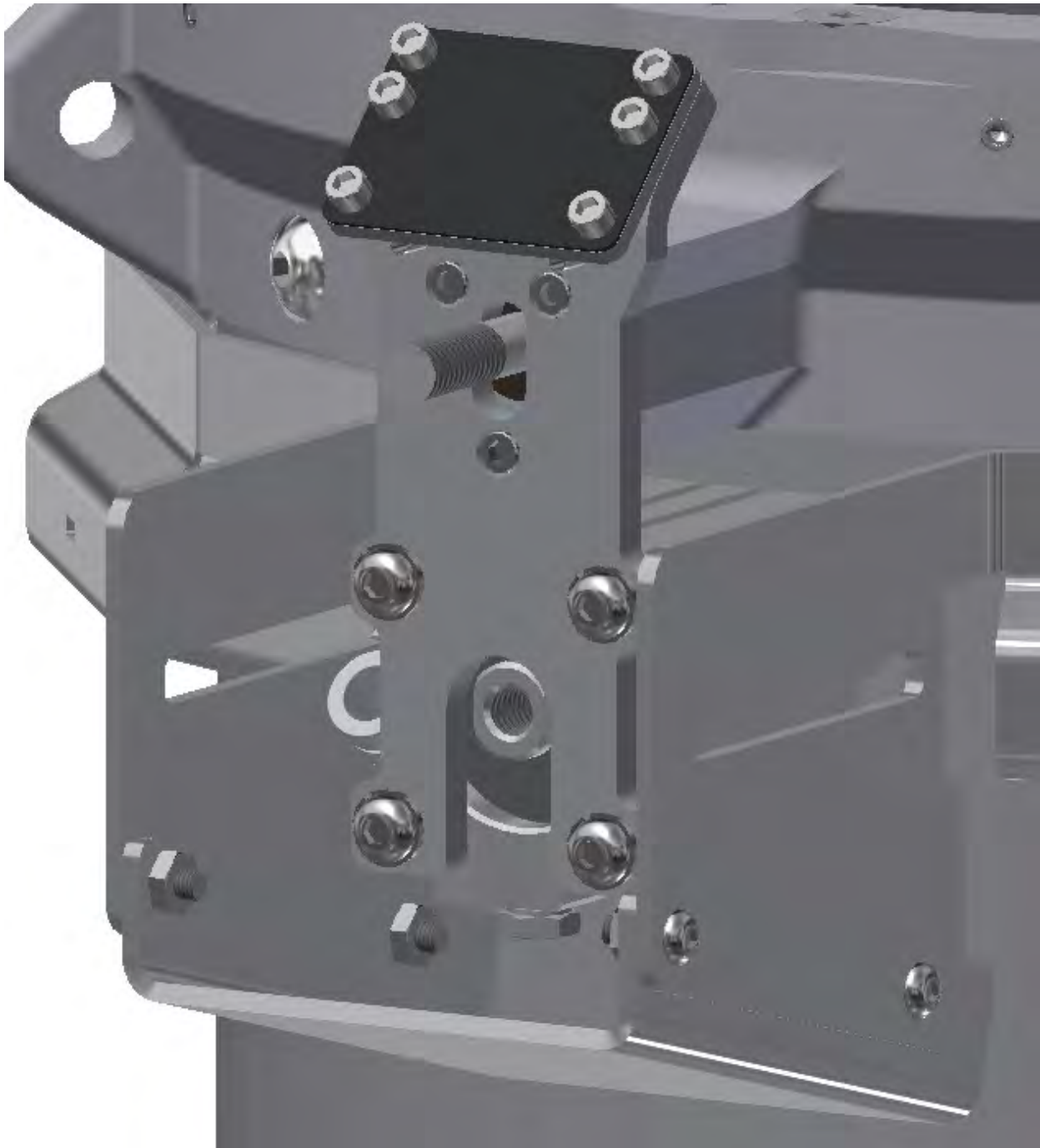

Figure 8-16 Assembled View

Note: The base tube collars are not fully assembled. Follow the procedures in Section 8.6.2 to complete both the intermediate tube setup and base tube setup.

8.6.2 Intermediate Tube Collar Setup

To set up the intermediate tube collar:

1. Pre-assemble the pin, spring, thrust bearing and spacer to the guide plate assembly. The slot on the guide plate assembly is cut in such a way that the pin should always be installed in the proper orientation.

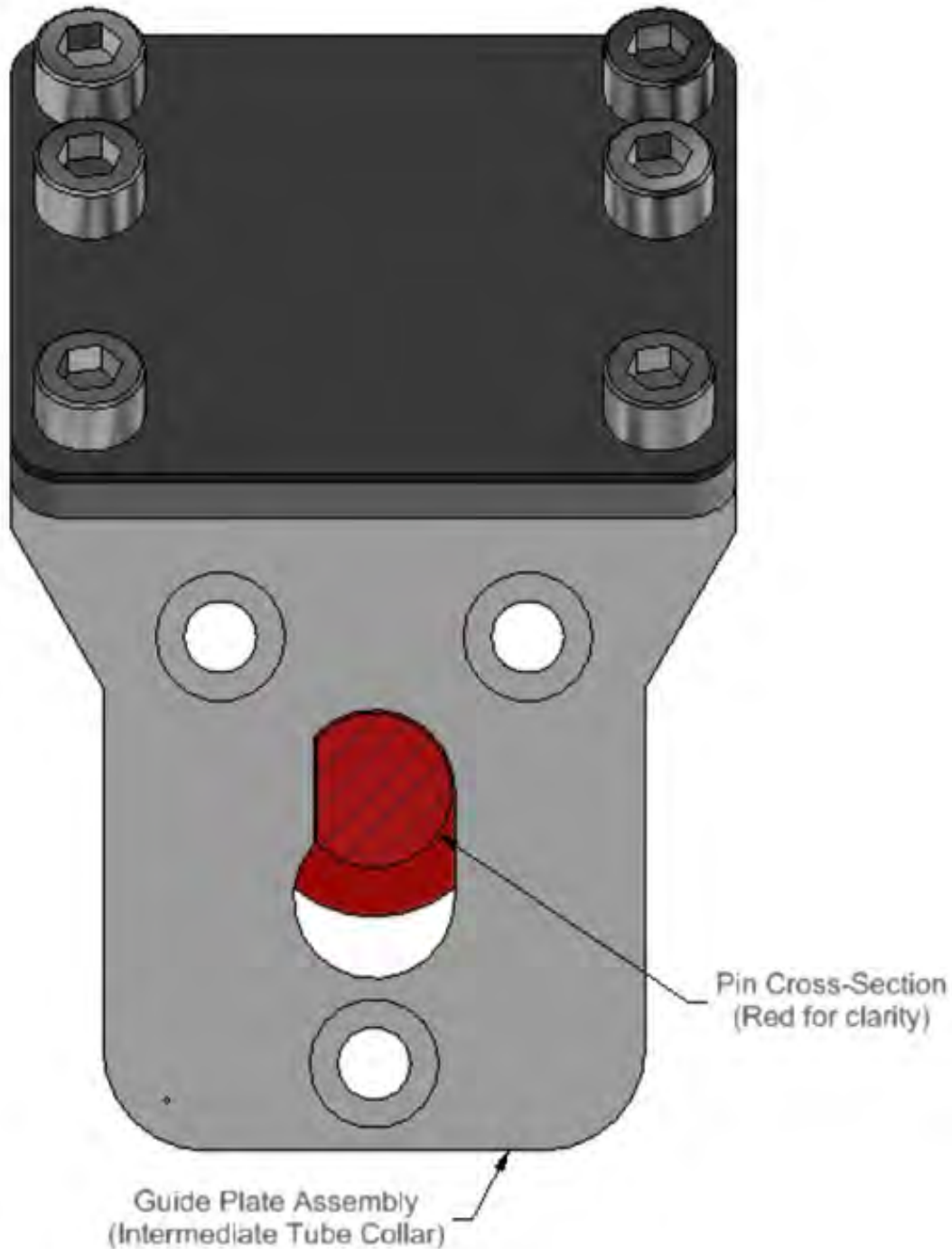

Figure 8-17 Preassemble Components to Guide Plate Assembly

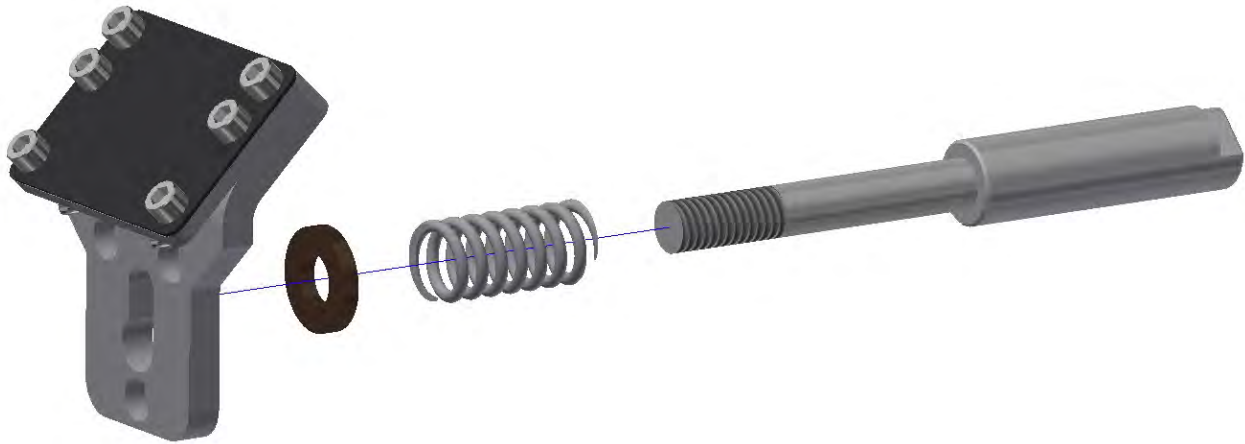

Figure 8-18 Assemble Components

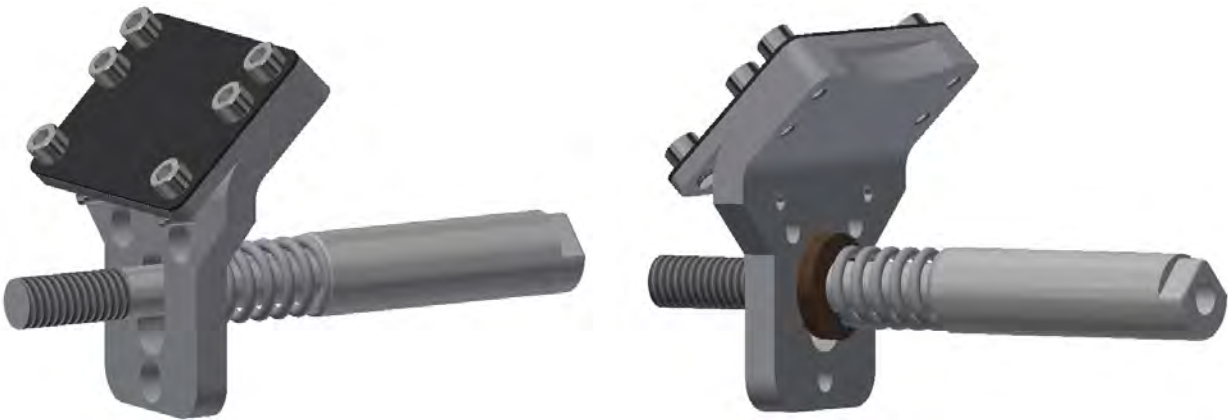

Figure 8-19 Front and Back Assembled Views

2. Apply blue Loctite 243 or equal to threaded holes of the collar (Figure 8-20).
3. Mount the guide plate assembly, pin, spring and thrust bearing to the collar using (3) #8 socket head cap screws.
4. Repeat steps 2 and 3 for both sides of the collar and to all of the remaining collars.

Note: You should feel resistance from the spring compressing when fastening back plate to collar.

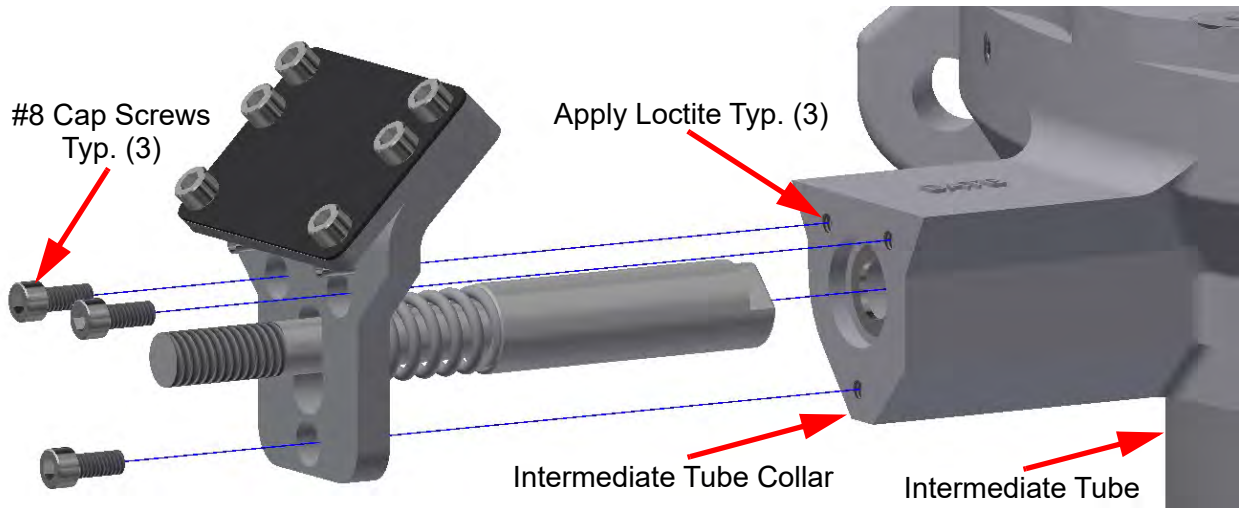

Figure 8-20 Assemble Components



Figure 8-21 Assembled View

Note: All of the tube section collars should now be assembled with their components.

5. Connect RLS control system to mast and fully extend mast and release pressure so that all tube sections are locked in place via the latch pins.
6. Apply anti-seize to threads of both pins on base tube collar as shown in Figure 8-22.
7. Fasten base tube latch lever to base tube pin using flat washer and nylock nut leaving a .100" gap between washer and latch lever. Use a .100" (2.54 mm) shim to ensure accurate spacing. Torque nylock nut so hardware just touches .100" (2.54 mm) shim. DO NOT OVER TIGHTEN.

Notes:

- Over tightening nylock nut will pull the pin away from the tube that it is locking in place.
- Clean off excess anti-seize around exposed threads with clean rag.

8. Repeat step 7 for both sides of the base tube collar

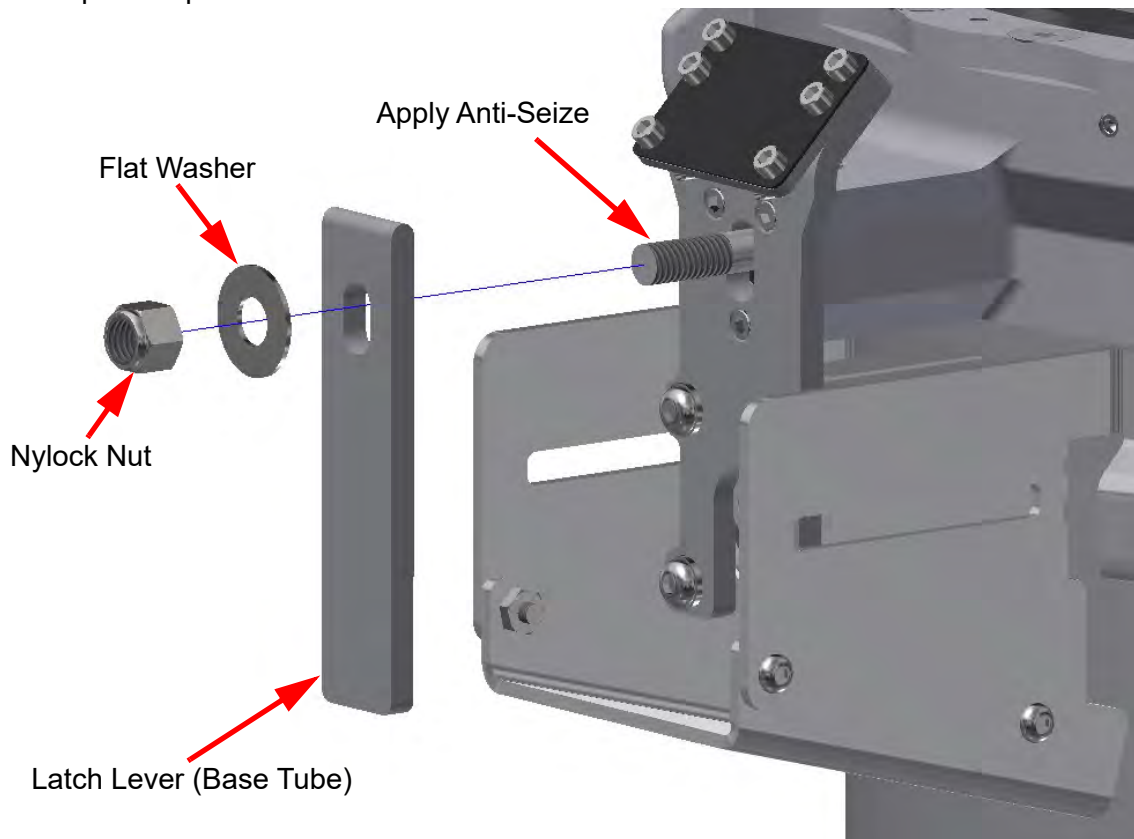

Figure 8-22 Assemble Components

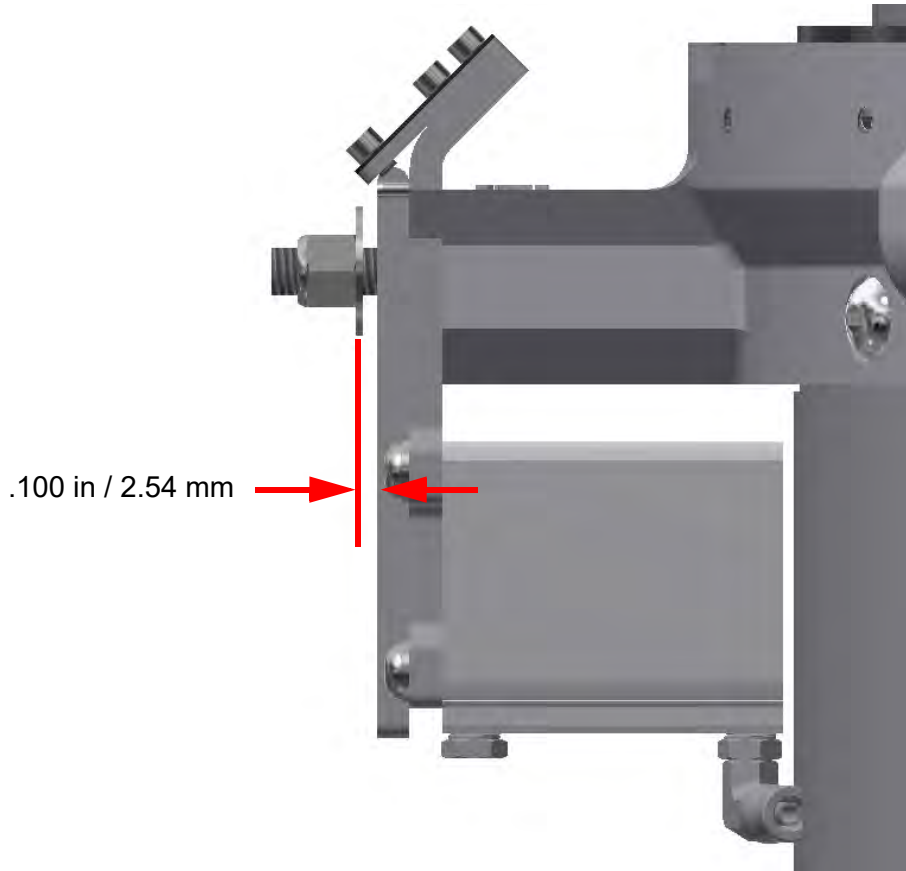

Figure 8-23 .100" Gap (Hose Guard Not Shown)

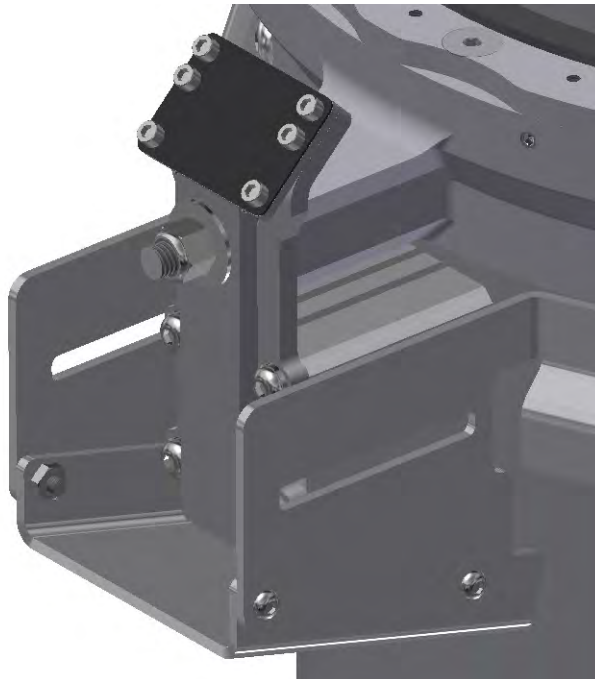

Figure 8-24 Assembled View

9. Once both latch levers are assembled to the mast, retract the first tube section until it is approximately 10 inches from the collar below.

Note: Do not fully retract the tube section or the latch lever will not be able to be installed onto the collar.

10. Apply anti-seize to threads of both pins on base tube collar as shown in Figure 8-25.
11. Fasten latch lever to pin using flat washer and nylock nut leaving a .100" gap between washer and latch lever. Use a .100" (2.54 mm) shim to ensure accurate spacing. Torque nylock nut so hardware just touches .100" (2.54 mm) shim. **DO NOT OVER TIGHTEN.**

Notes:

- Over tightening nylock nut will pull the pin away from the tube that it is locking in place.
- Clean off excess anti-seize around exposed thread with clean rag.

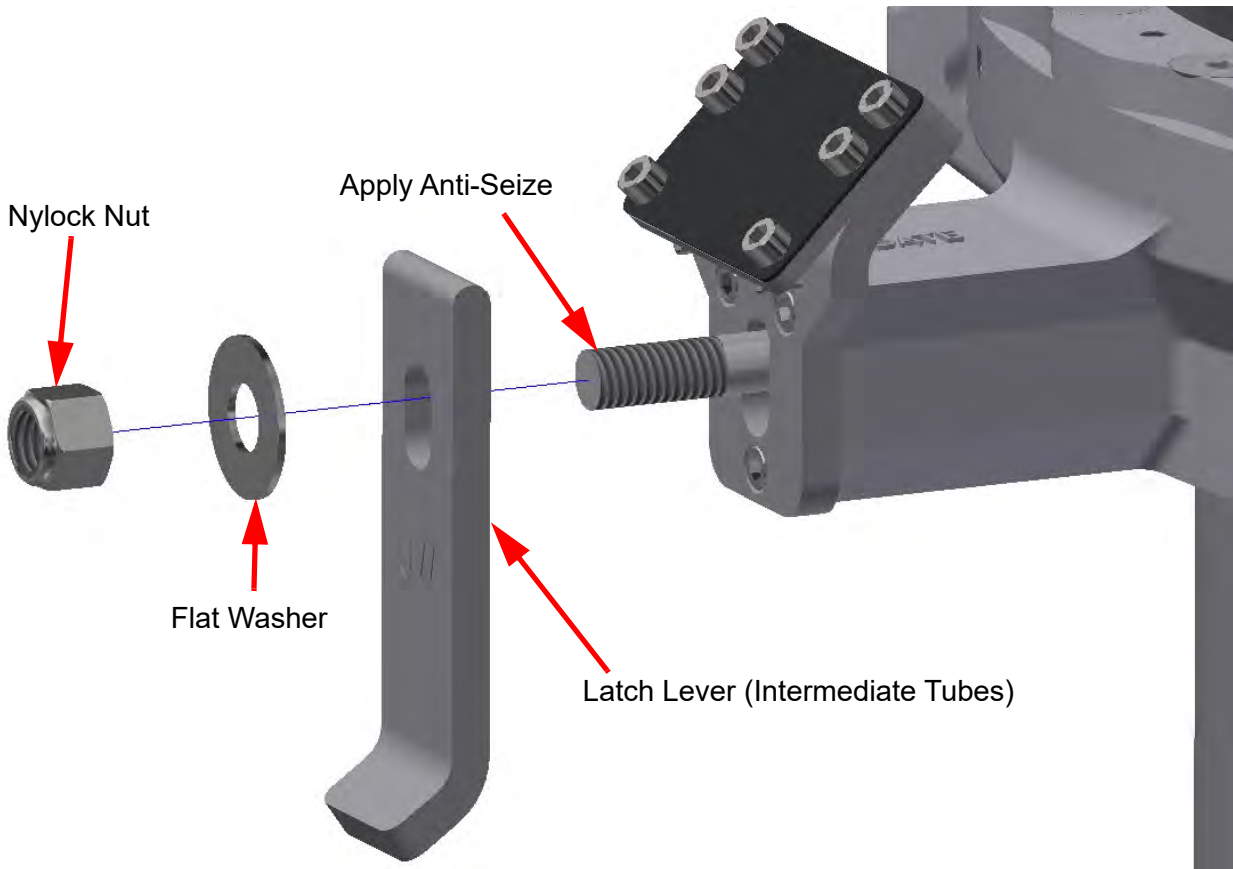

Figure 8-25 Assemble Components

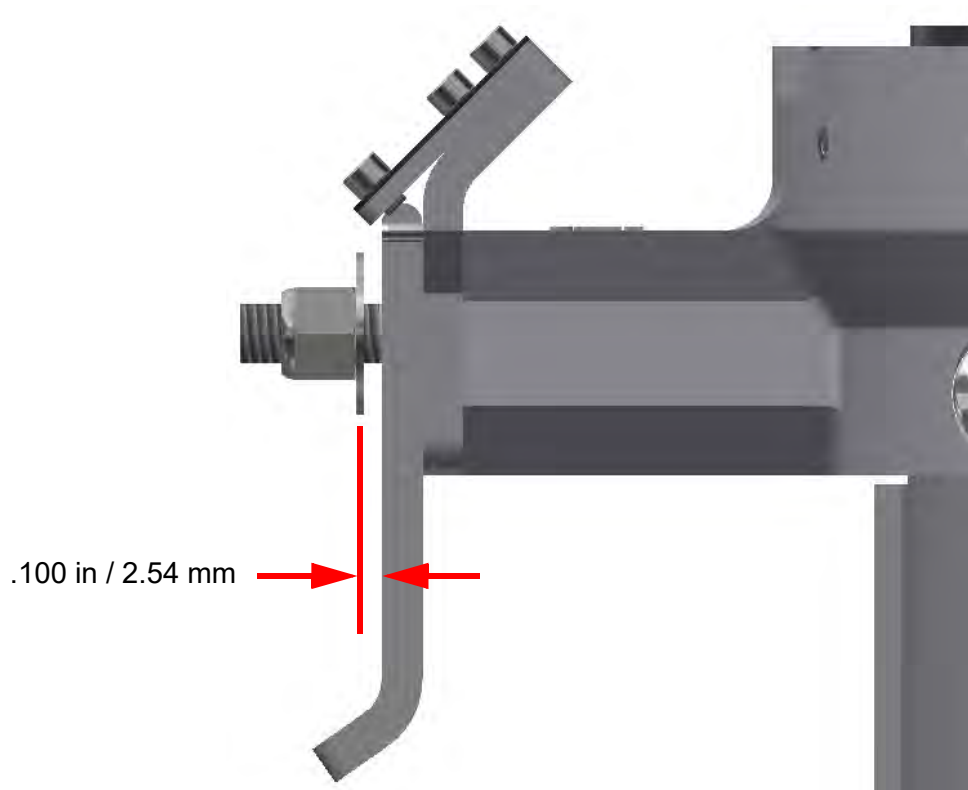

Figure 8-26 .100" Gap



Figure 8-27 Assembled View

12. Retract tube section by exhausting air in mast so that the (intermediate) latch lever contacts the guide plate assembly below. The next mast section should unlock.
13. Retract the next mast tube section until it is approximately 10 inches from the collar below.
14. Repeat steps 11 – 13 until all tube section collars are equipped with latch levers.



Figure 8-28 Fully Assembled View

8.7 Long-Term Storage

When putting the system into long-term storage, ensure the:

- Mast is fully nested (Section 6.3.1).
- Drain cock is open to eliminate the possibility of inadvertent mast extension.
- Mast is stored in a clean and dry environment.
- Mast is stored vertically when storing for more than six months with provisions to keep the mast from tipping over.
- Mast is extended and lowered every six months (Section 6.3.1).

8.8 System Disposal

Dispose of the mast in accordance with the national environmental regulations.

9 Troubleshooting

This section describes troubleshooting for the mast system. Use care to understand and follow all precautions while troubleshooting the mast system.

Table 9-1 Troubleshooting

Problem	Possible Cause	Possible Solution
Mast is frozen in the extended position		
	Base tube was not drained routinely. Typically freezes around collar area.	<ol style="list-style-type: none"> 1. Wrap warming blankets around collar until ice melts. Use a heat gun or 500W quartz light. 2. Depressurize mast. Inject 1 oz. Will-Burt Antifreeze (P/N: 4735801) where the top of the collar and intermediate tube meet.
	There is ice buildup on the exterior of the mast.	Follow the <i>Instructions for Clearing Ice Buildup on the Exterior of a Pneumatic Mast</i> (TP-5253501).
	Locks are stuck in the locked position due to lack of exercising	Use Lock Pin Extractor Kit (P/N: 5448601) (purchase separately)
Mast is frozen in nested position		
	Base tube was not drained routinely. Typically damages tubes.	Send to the manufacturer for repair or replacement.
Largest intermediate tube stuck		
	Support bracket too tight.	Loosen shims. Shim as necessary between clamp halves.
Cannot slide weather bonnet over the base tube		
	Weather bonnets are designed to be tight.	<ol style="list-style-type: none"> 1. Use soapy water. 2. Use a mallet to tap evenly around the diameter of the weather bonnet.

Table 9-1 Troubleshooting (Continued)

Problem	Possible Cause	Possible Solution
Mast will not lower without rocking		
	Not enough weight.	<ol style="list-style-type: none"> 1. See section for mast cleaning and lubrication. 2. Add weight to platform or stub adaptor.
	Bent tube.	Check tube trueness. If bent, order replacement.
	Broken internal bumper.	Depressurize mast. Remove the collar and lift the tube to check the internal bumper. If necessary, order replacement.
	Collar inserts tight.	Depressurize and disassemble mast. File or lightly grind to pre-fit collar inserts as necessary.
Base tube locks will not unlock		
	Not enough air pressure to actuate locks.	<ol style="list-style-type: none"> 1. Ensure the air supply is operational and the control box has power. 2. Ensure the air hose is not pinched.
Rotational movement in tubes		
	Bearing strips or inserts worn.	Locking strip collar: Order new bearing strips. Customer must pre-fit.
Air cylinders actuate but mast does not retract		
	Reed switch is out of proper placement.	Adjust reed switch. See Section 8.5.1.

For additional information, please contact The Will-Burt Company's Customer Service at +1 330 684 4000.

10 References

This section provides reference information for the system as follows:

- Extended Glossary of Terms (Section 10.1)
- Drawings (Section 10.2)
- System Wiring Diagram (Section 10.3)
- Mast Wind Load Capacity (10.4)

10.1 Extended Glossary of Terms

This section defines terms used within this manual as follows:

- General Terms and Abbreviations (Section 10.1.1)
- Mounting Position Terms (Section 10.1.2)

10.1.1 General Terms and Abbreviations

This section describes general terms and abbreviations used within this manual.

- **Amp:** stands for ampere, which is a unit of electric current.
- **AWG:** stands for American Wire Gauge.
- **Bar:** is a metric unit of pressure. One bar is approximately equal to the atmospheric pressure at sea level.
- **Base Tube:** refers to the tube with the largest diameter. When the mast is fully extended, this is the tube closest to the mounting surface.
- **BCD:** stands for Bolt Circle Diameter.
- **Bearing Strips:** refer to plastic strips located in some collars where tubes make contact with each other.
- **Butt Plate:** refers to the bottommost plate on each intermediate tube.
- **CFM:** stands for Cubic Feet per Minute.
- **Collar Inserts:** refer to machined pieces of plastic with a notch for the key located in some collars.
- **Collars:** attach to the top of each tube except the top tube.
- **Drain Hole:** refers to the threaded hole on the side of the base tube designed to facilitate the water drainage during periods of extension. A Drain Kit may be installed to the drain hole to route water away from the mast system. The base tube has one drain hole.
- **Extended:** refers to the partial- or full-raised position of the mast that the mast pneumatically goes to from the nested position. In the extended position, some or all the tubes have risen.
- **ft.-lb.:** stands for foot-pounds, which is a unit of torque equal to the force in pounds multiplied by the distance in feet to the pivot point.
- **HD:** stands for Heavy Duty.
- **HHRC:** stands for Hand-Held Remote Controller.
- **Hz:** stands for hertz and is defined as one cycle per second.
- **ID:** stands for Inside Diameter or the diameter to the inside edge of a circle.
- **in.-lb.:** stands for inch-pounds, which is a unit of torque equal to the force in pounds multiplied by the distance in inches to the pivot point.

- **Intermediate Tubes:** refer to the tubes between the base tube and the top tube. When referencing intermediate tubes, they are referenced from bottom to top. In context of the entire mast, tubes would be listed from bottom to top as: base tube, first intermediate tube, second intermediate tubes, etc., top tube.
- **LPM:** stands for liters per minute.
- **Mast:** refers to the telescoping Pneumatic Mast.
- **Mast System:** refers to the entire Pneumatic Mast System (telescoping mast, pneumatic system, mounting hardware, and additional accessories).
- **Nested:** refers to the position of the mast where no tubes have risen. The mast remains retracted. This position is sometimes referred to as “stowed”.
- **Nm or N·m:** stands for Newton-Meter, which is a form of torque.
- **NPT:** stands for “American National Standard Pipe Thread” or “National Pipe Thread” for short; a United States standard for thread specifications on pipes and fittings. NPT threads are tapered.
- **OD:** stands for Outside Diameter or the diameter to the outside edge of a circle.
- **Payload:** refers to the object or equipment being raised by the mast to an operational height.
- **PSI:** stands for pound-force per square inch.
- **PSIG:** stands for pound-force per square inch gauge. PSIG refers to a gauge that has been calibrated to read zero at sea level.
- **P/N:** stands for Part Number. These are The Will-Burt Company part numbers for various components in the mast system.
- **RLS:** stands for Remote Locking System.
- **SCFM:** stands for standard cubic feet per minute, or CFM adjusted to 14.7 PSI (1 Bar) and 68°F (20°C).
- **SHD:** stands for Super Heavy Duty.
- **Top Tube:** refers to the tube with the smallest diameter. When the mast is fully extended, this is the tube furthest from the mounting surface.
- **Top Tube Stop:** refers to the component at the top of the top tube. The top tube stop prevents the top tube from sliding too far down into a nested mast.
- **Tube Head:** refers to the component at the base of the base tube.
- **UHD:** stands for Ultra Heavy Duty.
- **Wear Rings:** refers to the preformed split synthetic bearings that fit in the wear ring groove around the butt plate above the seal on each interior tube. The wear rings guide the bottom of the tube through the next larger tube.
- **Weep Holes:** refer to the holes on the intermediate tubes which are designed to facilitate the drainage of water during periods of extension. Each intermediate tube has four weep holes.
- **Ø:** stands for diameter.

10.1.2 Mounting Position Terms

For the purposes of this manual, regions of the mounting location are defined as follows:

- **Mounting Structure:** the overall structure where the mast is mounted.
- **Mounting Surface:** the surface to which the base plate is secured. When installing inside a vehicle, this will likely be the floor.
- **Roof:** the horizontal surface to which the internal mounting kit is secured. This term applies to internal mount applications only.
- **Support Structure:** the vertical surface to which the external support bracket is secured. This term applies to external mount applications only.

10.2 Drawings

Refer to www.willburt.com for drawings of your mast system.

10.3 System Wiring Diagram

The system wiring diagram is as follows:

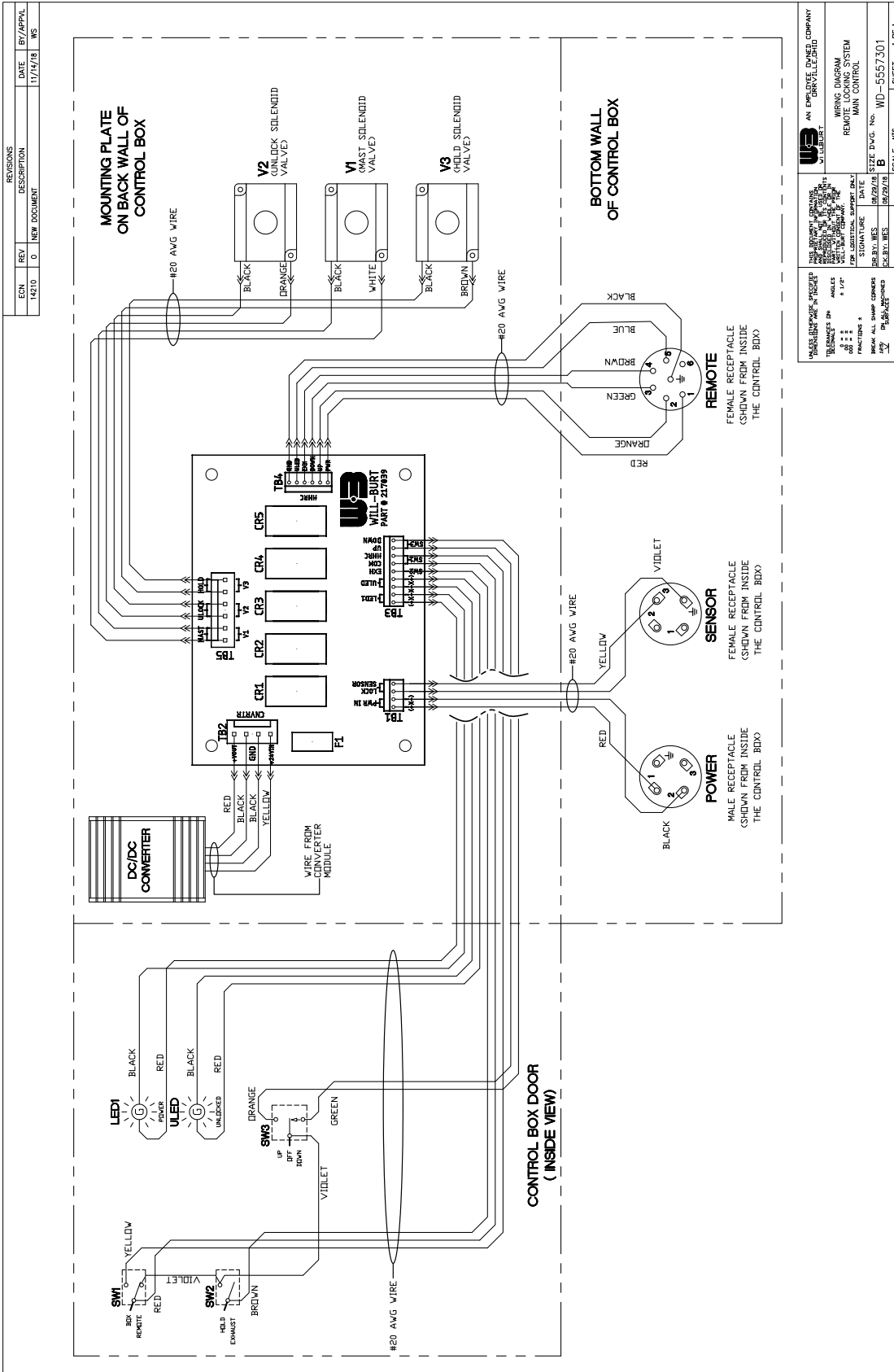

UNLESS OTHERWISE SPECIFIED DIMENSIONS ARE IN INCHES TOLERANCES ARE: ANGLES ± 1/4° FRACTIONS ± .005

WILL-BURT COMPANY
 1000 W. BURT BLVD.
 BRIDGEVILLE, OHIO 45130-1000
 TEL: 513-833-2200 FAX: 513-833-2201
 WWW.WILL-BURT.COM

DATE: 08/29/18
 DESIGNED BY: DR.BVJ.MES
 CHECKED BY: DR.BVJ.MES

AN EMPLOYEE OWNED COMPANY

WIRING DIAGRAM
 REMOTE LOCKING SYSTEM
 MAIN CONTROL

SIZE: DWG. NO. WD-5557301
 SHEET: 1 OF 1

10.4 Mast Wind Load Capacity

The following graphs define the survival wind speed capacity as a function of payload sail area. Note carefully the assumptions at the bottom of each graph. If your payload application exceeds any of these assumption values, contact The Will-Burt Company's Engineering for the wind load capacity for your specific application. These graphs are generic in nature and not intended to cover every possible payload situation. The wind load values represent a theoretical prediction of mast performance based on the assumptions used. Actual performance may vary slightly.

10.4.1 Catalog Model 6-25 HDL

6-25 Heavy Duty Locking Pneumatic Mast with Remote Locking System

Survival Wind Speed Performance Curve

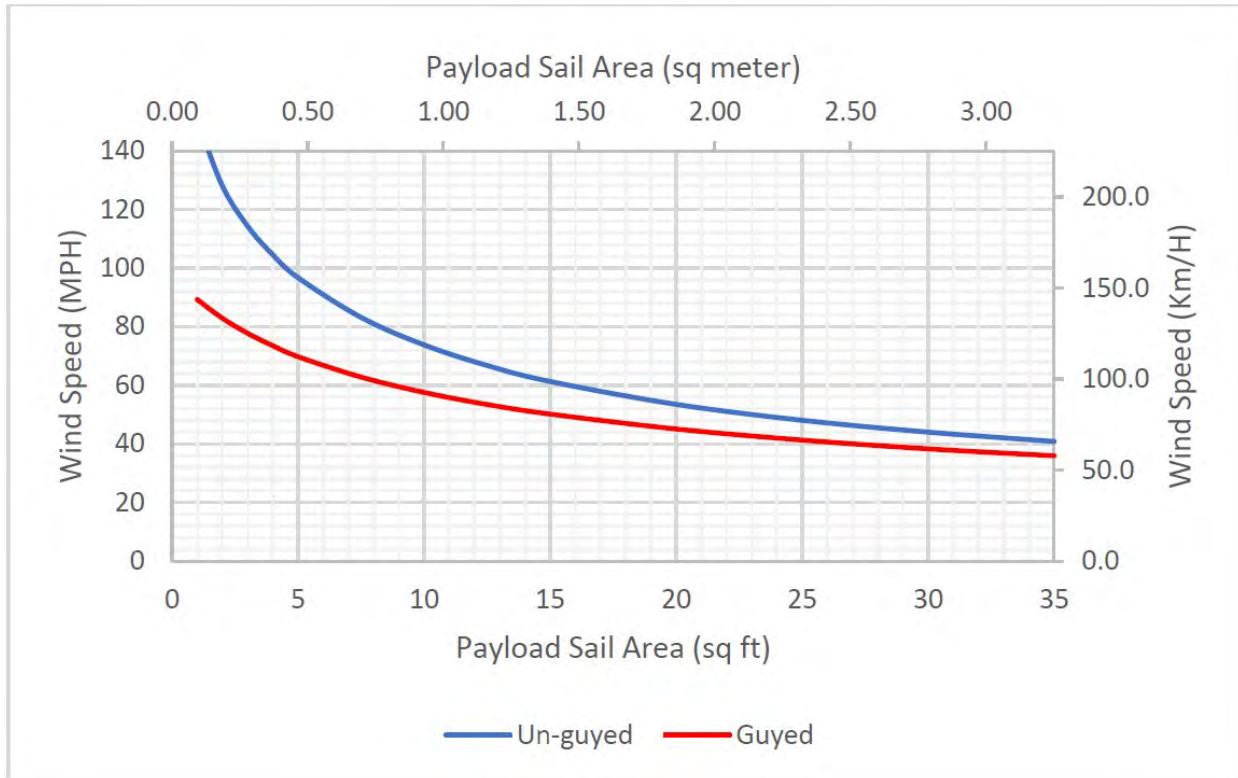

<p>Mast</p> <ul style="list-style-type: none"> 6-25 HDL Pneumatic Mast with Remote Locking System <ul style="list-style-type: none"> Nest Height = 6 ft. 1 in. [1.86 m] Fully Extended Height = 25 ft. 1 in. [7.65 m] No. of Tubes = 6 Tube Set = 3.00" – 6.75" Max Payload Capacity = 200 lb. [90.7 kg] 	<p>Guying Kit</p> <ul style="list-style-type: none"> WB P/N: 906236 1-level, 4-way guying to platform <ul style="list-style-type: none"> Used only 1 of 2 levels 25 ft. [7.62 m] guying radius ¼" Kevlar Guy Lines (4) Guy Stakes
<p>Survival Wind Speed Assumptions</p> <ul style="list-style-type: none"> Payload Weight = 200 lb. [90.7 kg] Payload Coefficient of Drag = 1.3 Payload centroid is on mast axis and 12" [304.8 mm] above top of mast Mast securely constrained at bottom of mast as well as approximately 5" [127 mm] below collar of base tube by WB supplied hardware or equivalent 0 degree mast base deployment angle All wind speeds measured at 33 ft above ground level Cabling is secured together and fixed to the mast Survival wind speed will be reduced for increasing payload centroid distance above top of mast This analysis does not include any evaluation of the stability of a trailer, the trailer, outriggers, and anchors are assumed fixed. 	

10.4.2 Catalog Model 7-30 HDL

7-30 Heavy Duty Locking Pneumatic Mast with Remote Locking System

Survival Wind Speed Performance Curve

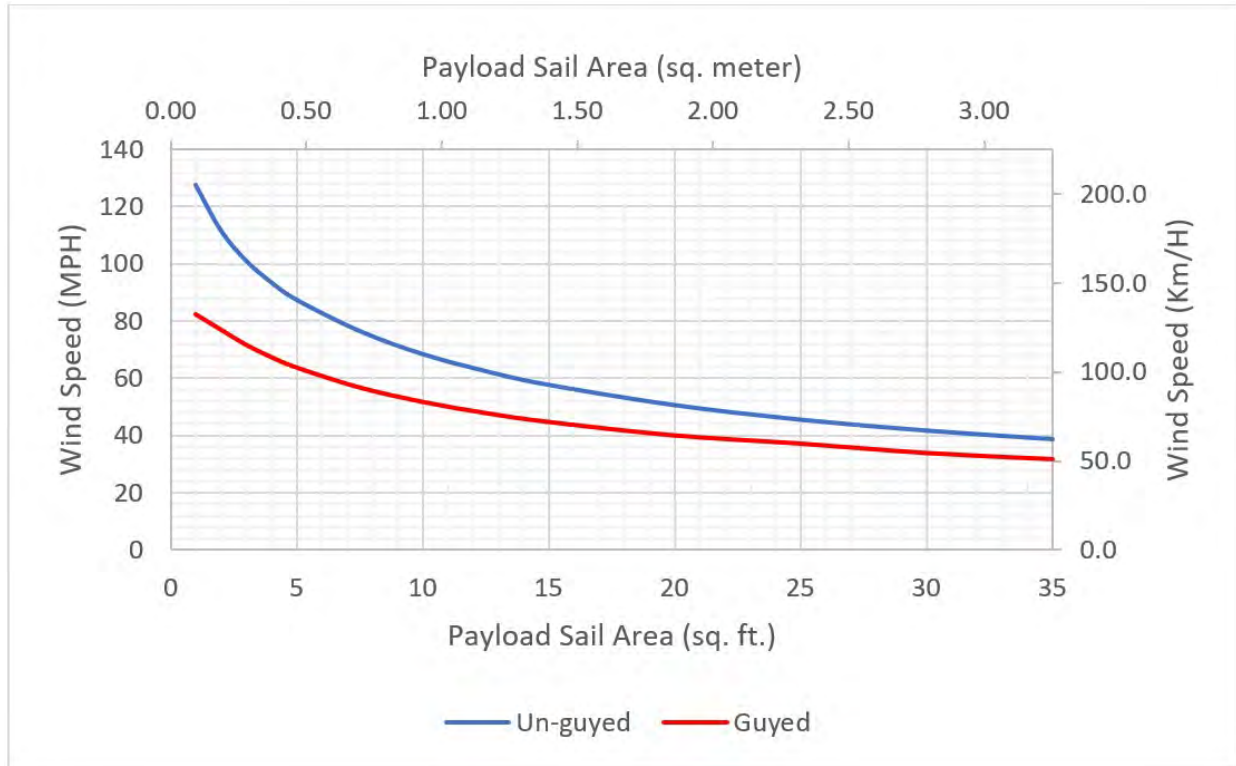

<p><u>Mast</u></p> <ul style="list-style-type: none"> 7-30 HDL Pneumatic Mast with Remote Locking System <ul style="list-style-type: none"> Nest Height = 7 ft. 0 in. [2.12 m] Fully Extended Height = 29 ft. 2 in. [8.89 m] No. of Tubes = 6 Tube Set = 3.00" – 6.75" Max Payload Capacity = 200 lb. [90.7 kg] 	<p><u>Guying Kit</u></p> <ul style="list-style-type: none"> WB P/N: 906162 2-level, 4-way guying to 3.75" and 5.25" collars 30 ft. [9.14 m] guying radius ¼" Kevlar Guy Lines (4) Arrowhead Anchors
<p><u>Survival Wind Speed Assumptions</u></p> <ul style="list-style-type: none"> Payload Weight = 200 lb. [90.7 kg] Payload Coefficient of Drag = 1.3 Payload centroid is on mast axis and 12" [304.8 mm] above top of mast Mast securely constrained at bottom of mast as well as approximately 5" [127 mm] below collar of base tube by WB supplied hardware or equivalent 0 degree mast base deployment angle All wind speeds measured at 33 ft above ground level Cabling is secured together and fixed to the mast Survival wind speed will be reduced for increasing payload centroid distance above top of mast This analysis does not include any evaluation of the stability of a trailer, the trailer, outriggers, and anchors are assumed fixed. 	

10.4.3 Catalog Model 7-42 HDL

7-42 Heavy Duty Locking Pneumatic Mast with Remote Locking System

Survival Wind Speed Performance Curve

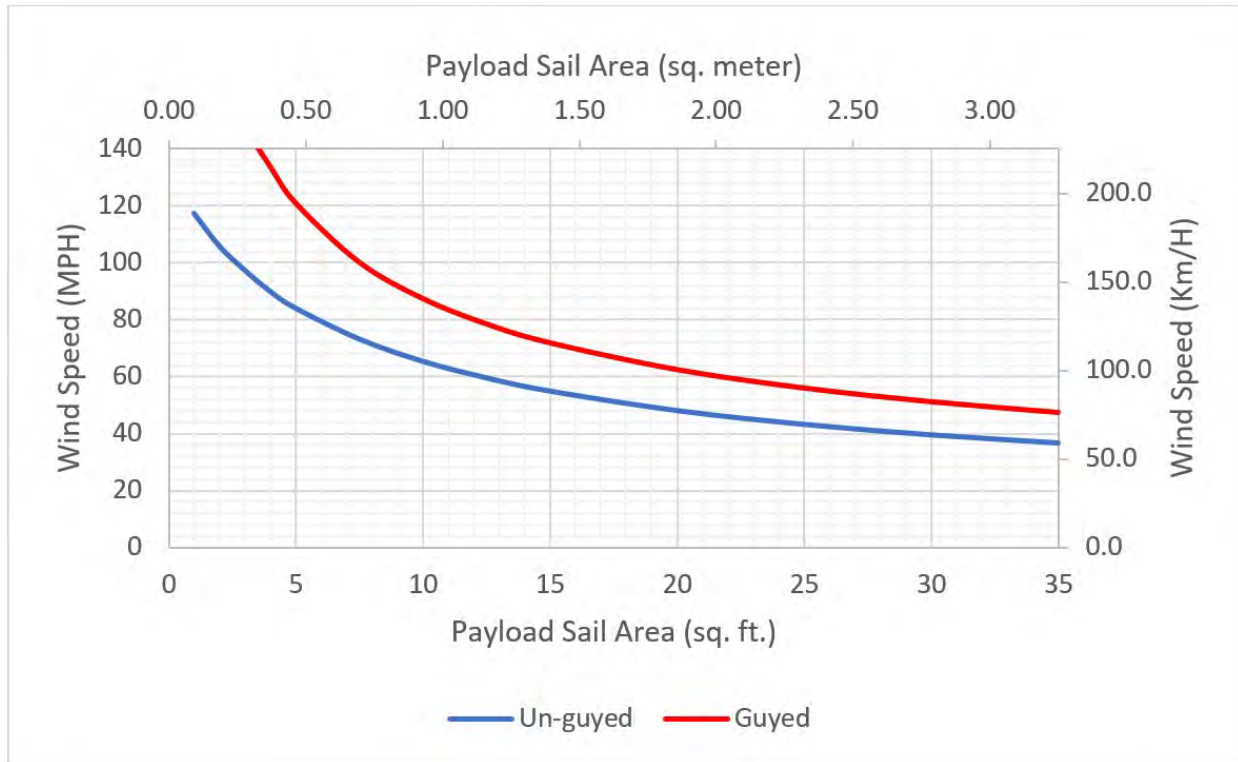

<p>Mast</p> <ul style="list-style-type: none"> 7-42 HDL Pneumatic Mast with Remote Locking System <ul style="list-style-type: none"> Nest Height = 7 ft. 8 in. [2.33 m] Fully Extended Height = 41 ft. 3 in. [12.58 m] No. of Tubes = 9 Tube Set = 3.00" – 9.00" Max Payload Capacity = 200 lb. [90.7 kg] 	<p>Guying Kit</p> <ul style="list-style-type: none"> WB P/N: 5221601 2-level, 4-way guying to 3.75" and 6.00" collars 30 ft. [9.14 m] guying radius 3/16" steel guy lines (4) 6" Screw Anchors
<p>Survival Wind Speed Assumptions</p> <ul style="list-style-type: none"> Payload Weight = 200 lb. [90.7 kg] Payload Coefficient of Drag = 1.3 Payload centroid is on mast axis and 12" [304.8 mm] above top of mast Mast securely constrained at bottom of mast as well as approximately 5" [127 mm] below collar of base tube by WB supplied hardware or equivalent 0 degree mast base deployment angle All wind speeds measured at 33 ft above ground level Cabling is secured together and fixed to the mast Survival wind speed will be reduced for increasing payload centroid distance above top of mast This analysis does not include any evaluation of the stability of a trailer, the trailer, outriggers, and anchors are assumed fixed. 	

10.4.4 Catalog Model 10-60 HDL

10-60 Heavy Duty Locking Pneumatic Mast with Remote Locking System

Survival Wind Speed Performance Curve

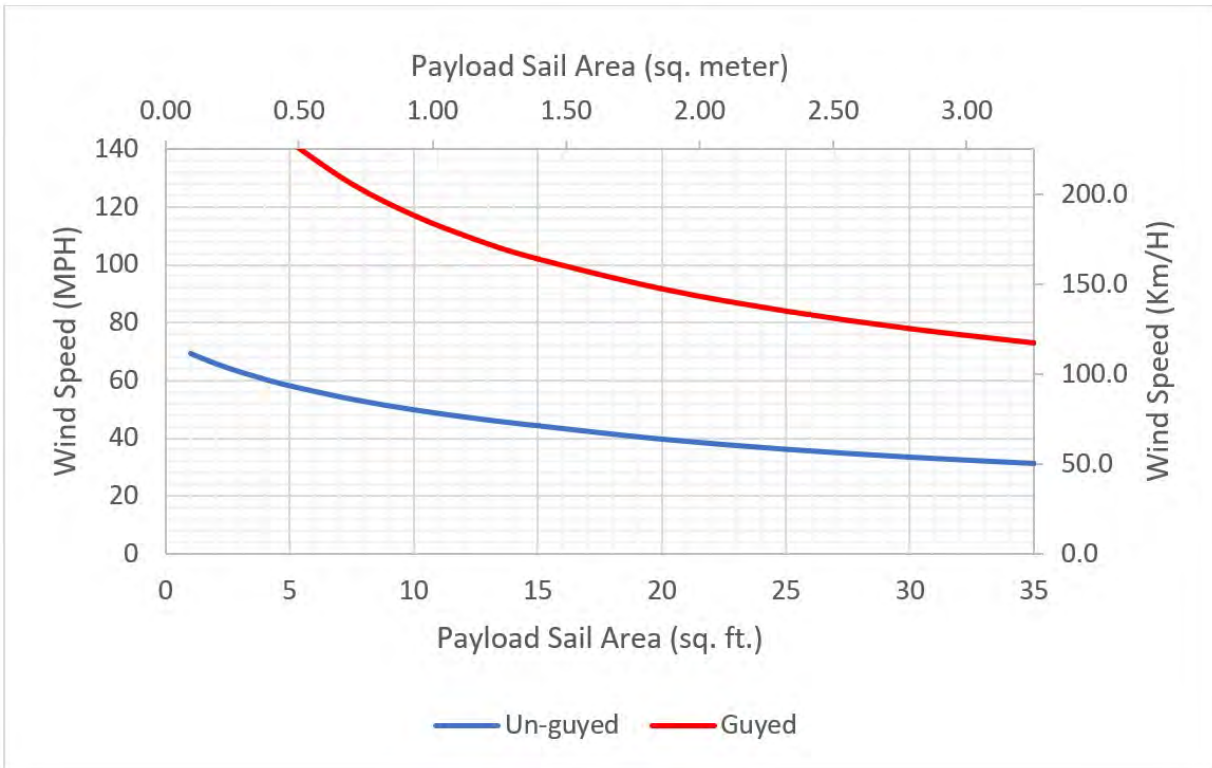

<p><u>Mast</u></p> <ul style="list-style-type: none"> • 10-60 HDL Pneumatic Mast with Remote Locking System <ul style="list-style-type: none"> • Nest Height = 10 ft. 2 in. [2.80 m] • Fully Extended Height = 60 ft. 5 in. [18.41 m] • No. of Tubes = 8 • Tube Set = 3.75" – 9.00" • Max Payload Capacity = 300 lb. [136.1 kg] 	<p><u>Guying Kit</u></p> <ul style="list-style-type: none"> • WB P/N: 5338101 • 2-level, 4-way guying to platform and 4.50" collar • 60 ft. [18.29 m] Guying Radius • 3/16" steel guy lines • (4) 6" Screw Anchors
<p><u>Survival Wind Speed Assumptions</u></p> <ul style="list-style-type: none"> • Payload Weight = 300 lb. [136.1 kg] • Payload Coefficient of Drag = 1.3 • Payload centroid is on mast axis and 12" [304.8 mm] above top of mast • Mast securely constrained at bottom of mast as well as approximately 5" [127 mm] below collar of base tube by WB supplied hardware or equivalent • 0 degree mast base deployment angle • All wind speeds measured at 33 ft above ground level • Cabling is secured together and fixed to the mast • Survival wind speed will be reduced for increasing payload centroid distance above top of mast • This analysis does not include any evaluation of the stability of a trailer, the trailer, outriggers, and anchors are assumed fixed. 	

10.4.5 Catalog Model 9-50 SHDL

9-50 Super Heavy Duty Locking Pneumatic Mast with Remote Locking System

Survival Wind Speed Performance Curve

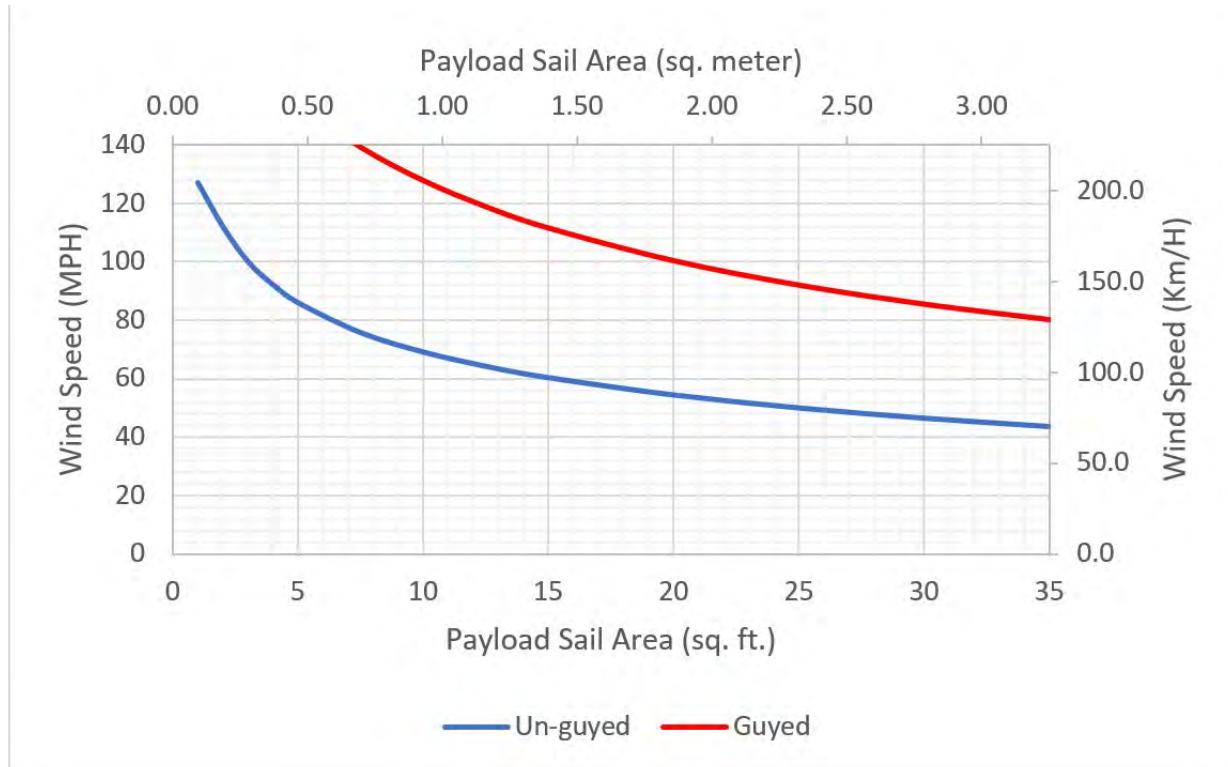

<p>Mast</p> <ul style="list-style-type: none"> 9-50 SHDL Pneumatic Mast with Remote Locking System <ul style="list-style-type: none"> Nest Height = 9 ft. 2 in. [2.80 m] Fully Extended Height = 50 ft. 6 in. [15.40 m] No. of Tubes = 8 Tube Set = 5.25" – 11.25" Max Payload Capacity = 530 lb. [240.4 kg] 	<p>Guying Kit</p> <ul style="list-style-type: none"> WB P/N: 4021701 2-level, 4-way guying to platform and 6.00" collar 50 ft. [15.24 m] Guying Radius 3/16" steel guy lines (4) 6" Screw Anchors
<p>Survival Wind Speed Assumptions</p> <ul style="list-style-type: none"> Payload Weight = 530 lb. [240.4 kg] Payload Coefficient of Drag = 1.3 Payload centroid is on mast axis and 12" [304.8 mm] above top of mast Mast securely constrained at bottom of mast as well as approximately 5" [127 mm] below collar of base tube by WB supplied hardware or equivalent 0 degree mast base deployment angle All wind speeds measured at 33 ft above ground level Cabling is secured together and fixed to the mast Survival wind speed will be reduced for increasing payload centroid distance above top of mast This analysis does not include any evaluation of the stability of a trailer, the trailer, outriggers, and anchors are assumed fixed. 	

10.4.6 Catalog Model 10.3-60 SHDL

10.3-60 Super Heavy Duty Locking Pneumatic Mast with Remote Locking System

Survival Wind Speed Performance Curve

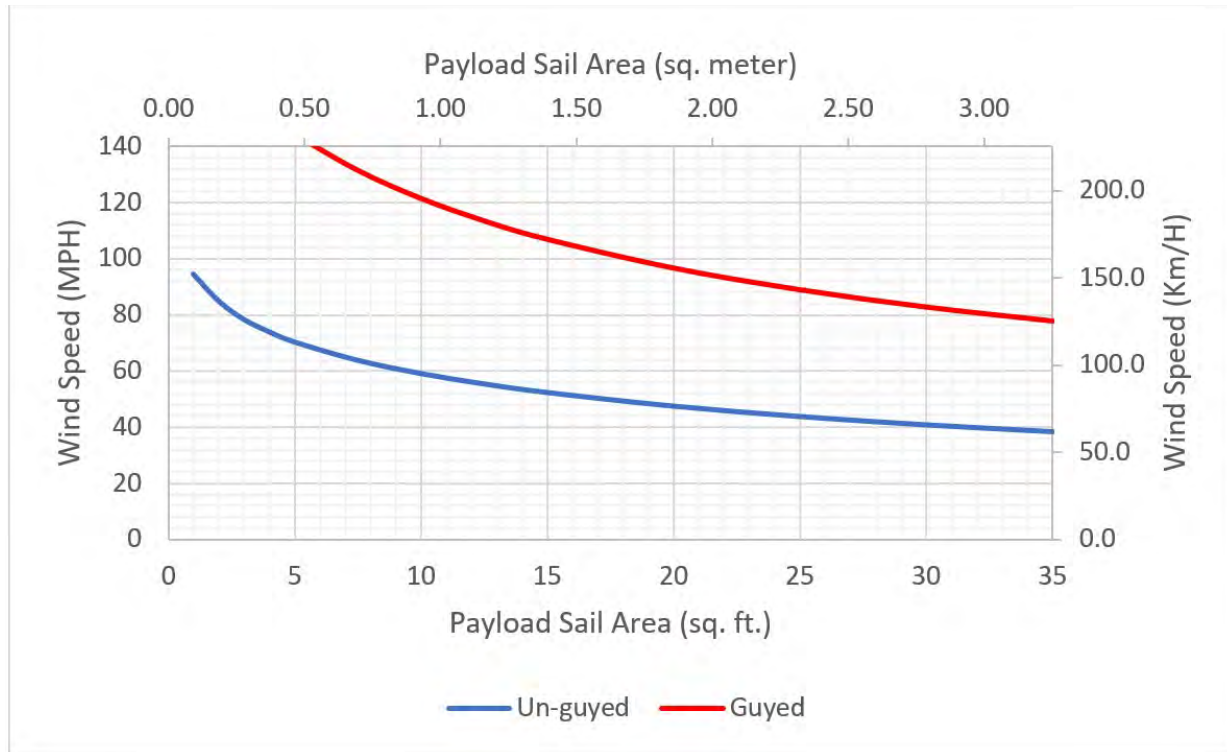

<p><u>Mast</u></p> <ul style="list-style-type: none"> 10.3-60 SHDL Pneumatic Mast with Remote Locking System <ul style="list-style-type: none"> Nest Height = 10 ft. 5 in. [3.19 m] Fully Extended Height = 60 ft. 6 in. [18.45 m] No. of Tubes = 8 Tube Set = 5.25" – 11.25" Max Payload Capacity = 530 lb. [240.4 kg] 	<p><u>Guying Kit</u></p> <ul style="list-style-type: none"> WB P/N: 909428 2-level, 4-way guying to platform and 6.00" collar 70 ft. [21.34 m] Guying Radius 3/16" steel guy lines (4) 6" Screw Anchors
<p><u>Survival Wind Speed Assumptions</u></p> <ul style="list-style-type: none"> Payload Weight = 530 lb. [240.4 kg] Payload Coefficient of Drag = 1.3 Payload centroid is on mast axis and 12" [304.8 mm] above top of mast Mast securely constrained at bottom of mast as well as approximately 5" [127 mm] below collar of base tube by WB supplied hardware or equivalent 0 degree mast base deployment angle All wind speeds measured at 33 ft above ground level Cabling is secured together and fixed to the mast Survival wind speed will be reduced for increasing payload centroid distance above top of mast This analysis does not include any evaluation of the stability of a trailer, the trailer, outriggers, and anchors are assumed fixed. 	

10.4.7 Catalog Model 8-39 UHDL

8-39 Ultra Heavy Duty Locking Pneumatic Mast with Remote Locking System

Survival Wind Speed Performance Curve

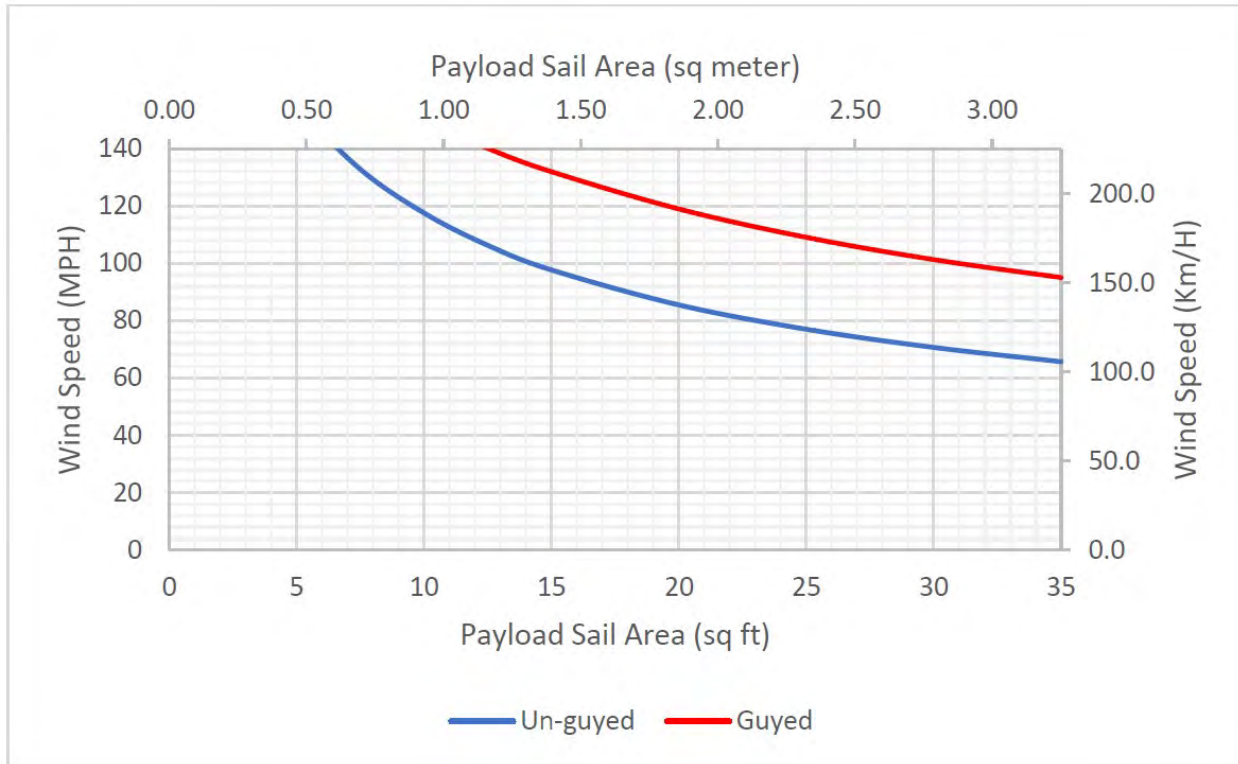

<p>Mast</p> <ul style="list-style-type: none"> 8-39 UHDL Pneumatic Mast with Remote Locking System <ul style="list-style-type: none"> Nest Height = 7 ft 10 in. [2.4 m] Fully Extended Height = 39 ft. 4 in. [12.0 m] No. of Tubes = 8 Tube Set = 6.75" – 13.50" Max Payload Capacity = 980 lb. [444.5 kg] 	<p>Guying Kit</p> <ul style="list-style-type: none"> WB P/N: 4519701 2-level, 4-way guying to platform and 7.50" collar 50 ft. [15.24 m] Guying Radius 3/16" steel guy lines (4) 6" Screw Anchors
<p>Survival Wind Speed Assumptions</p> <ul style="list-style-type: none"> Payload Weight = 980 lb. [444.5 kg] Payload Coefficient of Drag = 1.3 Payload centroid is on mast axis and 12" [304.8 mm] above top of mast Mast securely constrained at bottom of mast as well as approximately 5" [127 mm] below collar of base tube by WB supplied hardware or equivalent 0 degree mast base deployment angle All wind speeds measured at 33 ft above ground level Cabling is secured together and fixed to the mast Survival wind speed will be reduced for increasing payload centroid distance above top of mast This analysis does not include any evaluation of the stability of a trailer, the trailer, outriggers, and anchors are assumed fixed. 	

10.4.8 Catalog Model 11.3-59 UHDL

11.3-59 Ultra Heavy Duty Locking Pneumatic Mast with Remote Locking System

Survival Wind Speed Performance Curve

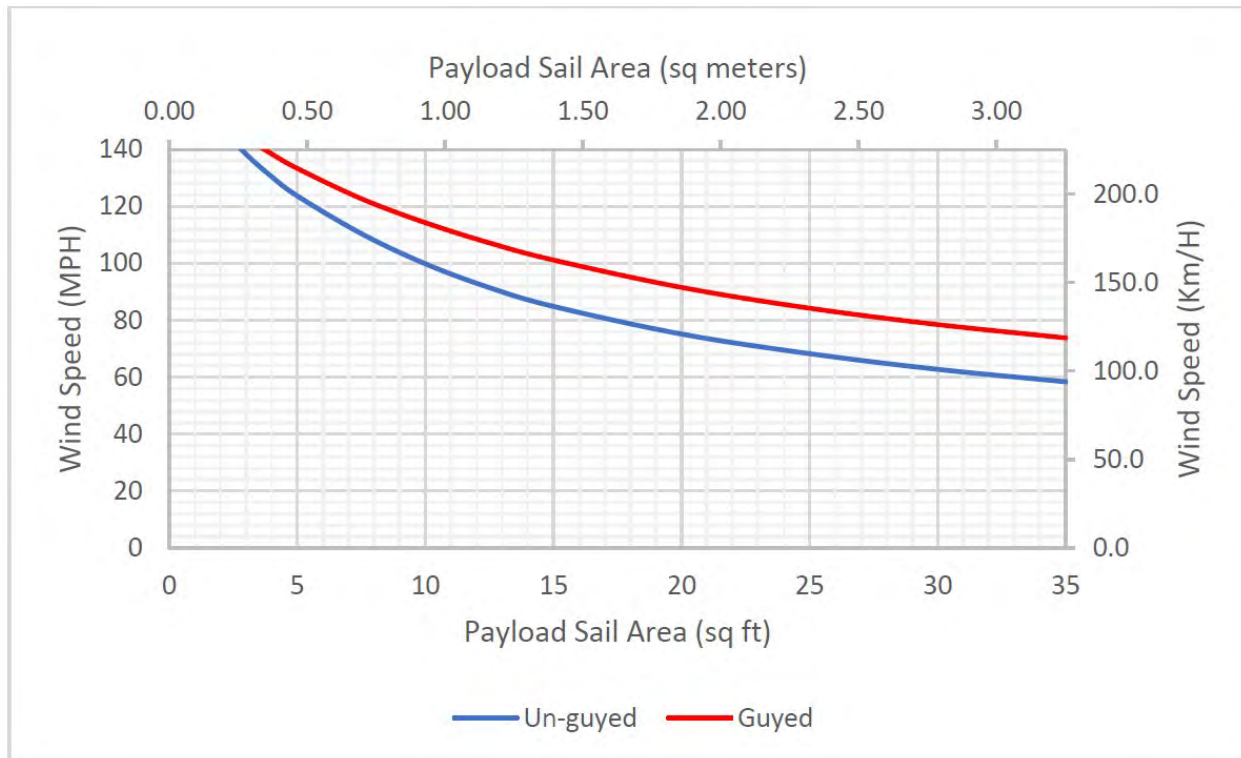

<p>Mast</p> <ul style="list-style-type: none"> 11.3-59 UHDL Pneumatic Mast with Remote Locking System <ul style="list-style-type: none"> Nest Height = 11 ft 4 in. [3.45 m] Fully Extended Height = 59 ft. 0 in. [18 m] No. of Tubes = 7 Tube Set = 7.50" – 13.50" Max Payload Capacity = 1,200 lb. [544.3 kg] 	<p>Guying Kit</p> <ul style="list-style-type: none"> WB P/N: 5034901 2-level, 4-way guying to platform and 9-1/8" collar 60 ft. [18.83 m] Guying Radius 3/16" steel guy lines (4) 6" Screw Anchors
<p>Survival Wind Speed Assumptions</p> <ul style="list-style-type: none"> Payload Weight = 1,200 lb. [544.3 kg] Payload Coefficient of Drag = 1.3 Payload centroid is on mast axis and 12" [304.8 mm] above top of mast Mast securely constrained at bottom of mast as well as approximately 5" [127 mm] below collar of base tube by WB supplied hardware or equivalent 0 degree mast base deployment angle All wind speeds measured at 33 ft above ground level Cabling is secured together and fixed to the mast Survival wind speed will be reduced for increasing payload centroid distance above top of mast This analysis does not include any evaluation of the stability of a trailer, the trailer, outriggers, and anchors are assumed fixed. 	

10.4.9 Catalog Model 3-20M UHDL

3-20M Ultra Heavy Duty Locking Pneumatic Mast with Remote Locking System

Survival Wind Speed Performance Curve

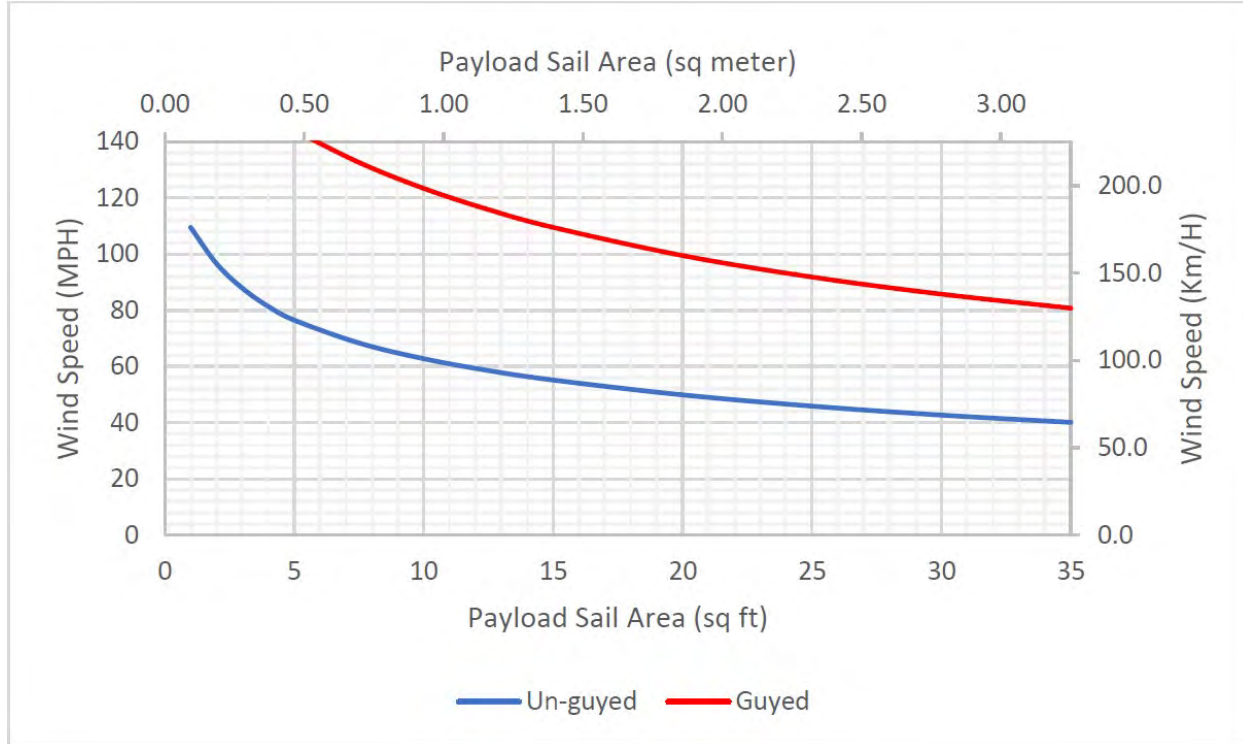

Mast

- 3-20M UHDL Pneumatic Mast with Remote Locking System
 - Nest Height = 9 ft 10 in. [3.0 m]
 - Fully Extended Height = 65 ft. 7 in. [20.0 m]
 - No. of Tubes = 10
 - Tube Set = 5.25" – 13.50"
 - Max Payload Capacity = 530 lb. [240.4 kg]

Guying Kit

- WB P/N: 5063301
- 2-level, 4-way guying to platform and 9.14" collar
- 58 ft. [17.8 m] Guying Radius
- 1/4" steel guy lines
- (4) 6" Screw Anchors

Survival Wind Speed Assumptions

- Payload Weight = 530 lb. [240.4 kg]
- Payload Coefficient of Drag = 1.3
- Payload centroid is on mast axis and 12" [304.8 mm] above top of mast
- Mast securely constrained at bottom of mast as well as approximately 5" [127 mm] below collar of base tube by WB supplied hardware or equivalent
- 0 degree mast base deployment angle
- All wind speeds measured at 33 ft above ground level
- Cabling is secured together and fixed to the mast
- Survival wind speed will be reduced for increasing payload centroid distance above top of mast
- This analysis does not include any evaluation of the stability of a trailer, the trailer, outriggers, and anchors are assumed fixed.

10.4.10 Catalog Model 14.3-80 UHDL

14.3-80 Ultra Heavy Duty Locking Pneumatic Mast with Remote Locking System

Survival Wind Speed Performance Curve

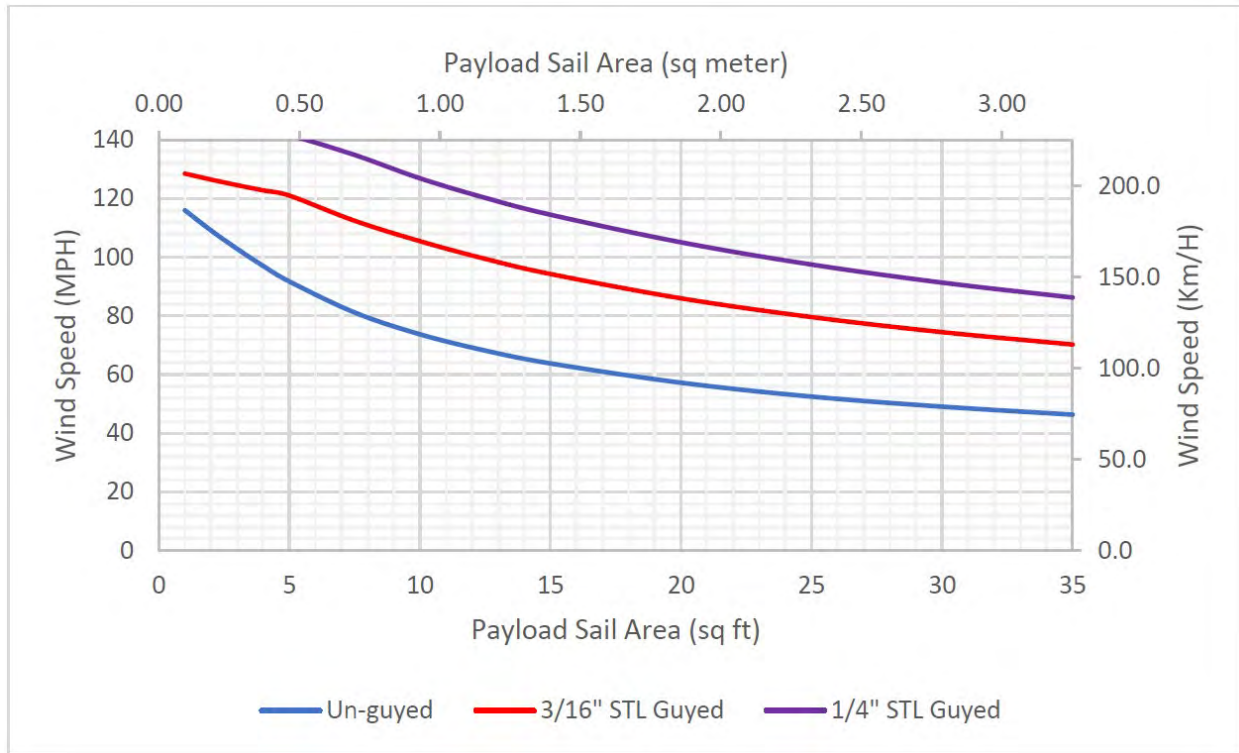

Mast	3/16" STL Guying Kit	1/4" STL Guying Kit
<ul style="list-style-type: none"> 14.3-80 UHDL Pneumatic Mast with Remote Locking System <ul style="list-style-type: none"> Nest Height = 14 ft 4 in. [4.37 m] Fully Extended Height = 80 ft. 1 in. [24.40 m] No. of Tubes = 7 Tube Set = 7.50" – 13.50" Max Payload Capacity = 1,200 lb. [544.3 kg] 	<ul style="list-style-type: none"> WB P/N: 5352801 2-level, 4-way guying to platform and 8.25" collar 70 ft. [21.34 m] Guying Radius 3/16" steel guy lines (4) 6" Screw Anchors 	<ul style="list-style-type: none"> WB P/N: 5365901 2-level, 4-way guying to platform and 8.25" collar 70 ft. [21.34 m] Guying Radius 1/4" steel guy lines (4) 6" Screw Anchors

Survival Wind Speed Assumptions
<ul style="list-style-type: none"> Payload Weight = 1,200 lb. [544.3 kg] Payload Coefficient of Drag = 1.3 Payload centroid is on mast axis and 12" [304.8 mm] above top of mast Mast securely constrained at bottom of mast as well as approximately 5" [127 mm] below collar of base tube by WB supplied hardware or equivalent 0 degree mast base deployment angle All wind speeds measured at 33 ft above ground level Cabling is secured together and fixed to the mast Survival wind speed will be reduced for increasing payload centroid distance above top of mast This analysis does not include any evaluation of the stability of a trailer, the trailer, outriggers, and anchors are assumed fixed.

This page intentionally left blank.

11 Document History

Table 11-1 Document History

Document Revision	Date	Change Details	Changes Backward Compatible with Previous Manual Version
TP-5580101-00	1/14/2019	Initial Release.	--
TP-5580101-A	Feb. 2022	Added Heavy Duty with RLS and Super Heavy Duty with RLS information.	Yes
TP-5580101-B	Nov. 2023	Added info to SWS section, updated retraction info, clarified reed switch info, updated graphics in Maintenance section, added collar setup section, updated control box graphics	Yes

This page intentionally left blank.